

WOL  
TL7

**ABK**

EMOZIONI IN SUPERFICIE



# VOL 17

**ABK**

EMOZIONI IN SUPERFICIE







25

YEARS  
OF ABK

ABK celebra 25 anni di attività, caratterizzati da successi e importanti trasformazioni, vissuti nel segno costante della crescita. Fin dalla sua nascita ABK ha puntato sulla qualità, con un'attenzione particolare rivolta alla decorazione d'interni. I costanti investimenti in ricerca e sviluppo hanno permesso all'Azienda di unire all'eccellenza estetica l'utilizzo esclusivo di nuove tecnologie in grado di elevare gli standard del prodotto, ridefinendo l'immagine stessa del brand nel panorama mondiale della produzione ceramica.

ABK is celebrating 25 years of business success, a quarter of a century marked by major transformations and steady growth. Ever since its inception, ABK has been committed to delivering high-quality solutions with a special focus on interior decoration. Thanks to its ongoing R&D investments, the company has combined aesthetic excellence with the use of exclusive new technologies to further raise its product standards and reaffirm the brand's image in the world ceramic tile market.

# ABK

## time line

1992

ABK nasce ufficialmente a Finale Emilia, come azienda produttrice di rivestimenti ceramici.

ABK is officially established in Finale Emilia as a ceramic tile manufacturer.

1996

ABK rileva lo storico marchio Ceramica Campeginese, specializzato nel rivestimento di fascia alta.

ABK acquires the historic brand Ceramica Campeginese, a specialist in high-end ceramic tiles.

1999

Con l'acquisizione di Imoker, ABK incrementa la produzione di pavimenti in gres porcellanato.

ABK increases its output of porcelain floor tiles with the acquisition of Imoker.

2000

La società ABK Group entra in possesso del marchio Ariana e dello stabilimento di Castellarano (RE).

ABK Group acquires the Ariana brand and its factory in Castellarano (RE).

2004

Il nuovo millennio scopre il minimalismo: nasce il progetto EVOLUTION.

The new millennium discovers minimalism with the EVOLUTION collection.

la collezione PETRAIA è una delle proposte più complete ispirate al fascino tradizionale del cotto.

Launch of PETRAIA, one of the most comprehensive collections inspired by the timeless appeal of terracotta.

2005

Il nuovo logo "ABK emozioni in superficie" identificherà d'ora in poi tutte le produzioni del brand.

The new "ABK emozioni in superficie" logo is introduced to identify all the brand's products.

2007

L'azienda acquisisce il nuovo sito produttivo di Solignano Nuovo (MO), insieme all'utilizzo dei brands Flaviker e Pi.Sa.

The company acquires the new production site in Solignano Nuovo (MO) along with the brand names Flaviker and Pi.Sa.

2012

L'effetto legno SOLERAS conquista il grande pubblico grazie alle nuove rivoluzionarie tecniche di decorazione digitale.

The new SOLERAS wood effect collection proves a big success with consumers thanks to the use of revolutionary digital decoration techniques.

2013

La tecnologia Auto-Leveling permette di posare facilmente doghe ceramiche lunghe 170 cm.

Auto-Leveling technology allows ceramic planks of length 170 cm to be installed with ease.

2014

La nuova pasta bianca da rivestimento W&P raggiunge la dimensione record di 60x120 .

The new W&P white body wall tiles reach a record size of 60x120 cm.

Il simbolo LEED Accordant compare sulla maggior parte dei prodotti presenti sul catalogo ABK.

The LEED Accordant symbol appears on most products in the ABK catalogue.

2015

INTERNO 9 si fa interprete della nuova tendenza "industrial".

Launch of INTERNO 9 collection embracing the industrial trend.

L'azienda di adesivi e sigillanti HARDKOLL è al 100% di ABK Group.

ABK Group completes 100% acquisition of adhesives and grout manufacturer HARDKOLL.

2016

ABK installa il forno ceramico più grande d'Italia e avvia la produzione di lastre ceramiche di grande formato sulla linea continua+.

ABK installs the largest ceramic kiln in Italy and begins production of large-format ceramic slabs on the Continua+ line.

ABK is

A decorative graphic consisting of two rows of vertical brown lines. The top row has 14 lines, and the bottom row has 6 lines. The word 'innovation' is centered between these two rows.

# innovation

ABK amplia le destinazioni d'uso della ceramica con una gamma prodotto sempre più diversificata e all'avanguardia, pensata per offrire soluzioni tecniche e compositive sempre nuove, applicabili sia nell'architettura residenziale che in ambito pubblico e commerciale.

With its increasingly diversified cutting-edge product range, ABK is constantly expanding the field of application of ceramic tiles. Its innovative technical and compositional solutions are ideal for use both in residential architecture and in public and commercial spaces.







# trends

Seguendo l'evoluzione del gusto e del mercato ABK continua il proprio percorso di ricerca in costante dialogo con il mondo dell'interior design, sviluppando una visione sempre originale e ricercata del prodotto.

As part of an original and sophisticated product vision, ABK is pursuing its research efforts in partnership with the world of interior design and in step with the latest market trends.



# crossover

Al servizio del privato e del professionista, ABK trasforma le superfici ceramiche in vere e proprie "emozioni" in grado di imprimere un tratto distintivo ad ogni progetto. La nuova gamma ABK privilegia le combinazioni stilistiche e la creatività si esprime attraverso l'incontro studiato fra le diverse sensazioni materiche.

Focused on the needs of both consumers and professionals, ABK transforms ceramic surfaces into emotions and lends uniqueness to every project. The new ABK range offers enormous scope for stylistic combinations and enhances creativity with a meticulously crafted blend of material effects.

**ABK**

EMOZIONI IN SUPERFICIE

# indice alfabetico

## ALPHABETICAL INDEX

<b>GRES PORCELLANATO</b>		
PORCELAIN STONEWARE		
ALPES WIDE		158
ALPES RAW		170
DOCKS		76
DOLPHIN		238
DOWNTOWN		50
DOWNTOWN COLOURS		68
EVOLUTION		104
FOSSIL		228
GRACE		150
INTERNO 9 WIDE		18
INTERNO 9		30
LEVEL		110
PAPIER		96
PETRAIA		268
PLAY WOOD		264
RE-WORK		206
SENSI WIDE		116
SENSI		132
SOLERAS		252
UNIKA		186
ZANZIBAR		282

<b>OUT.20 20MM</b>		
DOLPHIN		294
RE-WORK		292
SOLERAS		296
UNIKA		290

<b>W&amp;P PASTA BIANCA DA RIVESTIMENTO</b>		
WHITE BODY WALL TILE		
DO UP		300
DO UP TOUCH		310

<b>RIVESTIMENTI CONTEMPORANEI</b>		
CONTEMPORARY WALL TILES		
AQUA		354
GRACE		336
PAPIER		320
SECRET		328
TRACKS		348
VISION		360
ZANZIBAR		366

<b>COLLANTI E SIGILLANTI PER EDILIZIA</b>		
BUILDING ADHESIVES AND SEALANTS		
HARDKOLL		370

<b>INFORMAZIONI TECNICHE</b>		
TECHNICAL INFORMATION		
		374

# indice per formato

## INDEX BY SIZE

### GRES PORCELLANATO PAVIMENTI E RIVESTIMENTI

PORCELAIN STONEWARE FLOOR & WALL TILES

<b>160x320</b>	ALPES WIDE INTERNO 9 WIDE SENSI WIDE	158 18 116	<b>20x80</b>	DOCKS DOWNTOWN FOSSIL RE-WORK SOLERAS PLAYWOOD	76 50 228 206 252 264	<b>20x40</b>	RE-WORK UNIKA	206 186
<b>160x160</b>	ALPES WIDE INTERNO 9 WIDE SENSI WIDE	158 18 116	<b>13,5x80</b>	SOLERAS	252	<b>7x28</b>	DOLPHIN	238
<b>120x240</b>	ALPES WIDE INTERNO 9 WIDE SENSI WIDE	158 18 116	<b>60x60</b>	ALPES RAW DOWNTOWN DOWNTOWN COLOURS EVOLUTION GRACE INTERNO 9 LEVEL PAPIER RE-WORK SENSI SOLERAS UNIKA	170 50 68 104 150 30 110 96 206 132 252 186	<b>20x20</b>	RE-WORK UNIKA	206 186
<b>120x120</b>	ALPES WIDE INTERNO 9 WIDE SENSI WIDE	158 18 116	<b>30x60</b>	ALPES RAW DOWNTOWN DOWNTOWN COLOURS EVOLUTION FOSSIL LEVEL INTERNO 9 RE-WORK SENSI UNIKA	170 50 68 104 228 110 30 206 132 186	<b>OUT.20 20MM</b>		
<b>80x160</b>	ALPES WIDE INTERNO 9 WIDE SENSI WIDE	158 18 116	<b>15x60</b>	DOCKS UNIKA	76 186	<b>30x120</b>	DOLPHIN SOLERAS	238 252
<b>40x170</b>	DOLPHIN SOLERAS	238 252	<b>50x50</b>	FOSSIL PETRAIA ZANZIBAR	228 268 282	<b>40x80</b>	RE-WORK UNIKA	206 186
<b>20x170</b>	DOLPHIN SOLERAS	238 252	<b>33,3x33,3</b>	PETRAIA ZANZIBAR	268 282			
<b>60x120</b>	ALPES RAW INTERNO 9 SENSI UNIKA SENSI WIDE	158 30 132 186 158	<b>16,65x33,3</b>	PETRAIA	268			
<b>30x120</b>	INTERNO 9 SENSI UNIKA	30 132 186	<b>16,65x16,65</b>	PETRAIA	268			
<b>20x120</b>	DOLPHIN SOLERAS	238 252	<b>30x30</b>	DOWNTOWN	50			
<b>80x80</b>	ALPES WIDE DOCKS DOWNTOWN INTERNO 9 WIDE RE-WORK SENSI WIDE	158 76 50 18 206 116	<b>10x30</b>	SENSI UNIKA	132 186			
<b>40x80</b>	DOCKS DOWNTOWN FOSSIL RE-WORK UNIKA	76 50 228 206 186						

gres  
porcellanato

**PAVIMENTI E RIVESTIMENTI**

porcelain  
stoneware

**FLOOR & WALL TILES**

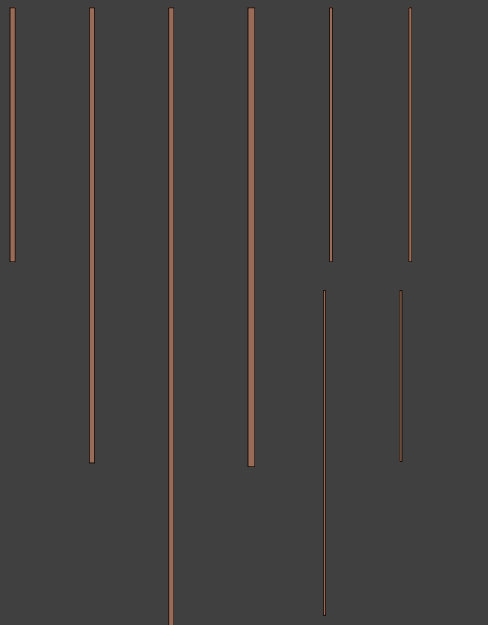

<b>CONTEMPORARY</b>	INTERNO 9 <small>WIDE</small>	18
	INTERNO 9	30
	DOWNTOWN	50
	DOWNTOWN COLOURS	68
	DOCKS	76
	PAPIER	96
	EVOLUTION	104
	LEVEL	110
<b>MARBLE</b>	SENSI <small>WIDE</small>	116
	SENSI	132
	GRACE	150
<b>STONE</b>	ALPES <small>WIDE</small>	158
	ALPES RAW	170
	UNIKA	186
	RE-WORK	206
	FOSSIL	228
<b>WOOD</b>	DOLPHIN	238
	SOLERAS	252
	PLAYWOOD	264
<b>RUSTIC</b>	PETRAIA	268
	ZANZIBAR	282

# Interno 9

**WIDE**  
SUPERSIZE SLABS

## LASTRE IN GRES PORCELLANATO PRESSATO A SECCO

DRY-PRESSED PORCELAIN STONEWARE SLABS

### SUPERFICI SURFACES

naturale - natural

### FORMATI SIZES

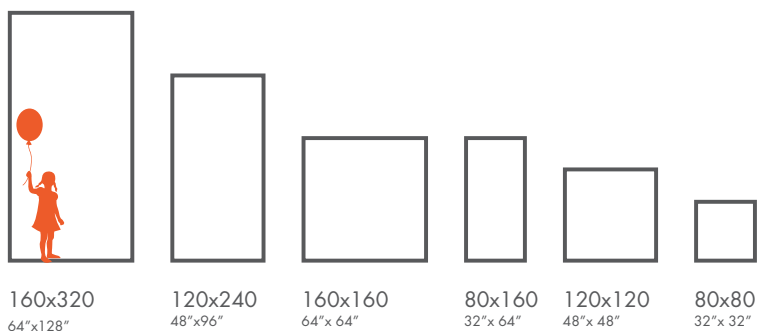

7 mm

Classificazione secondo norme UNI EN 14411 (ISO 13006) Allegato G Gruppo Bla  
Classification in accordance with UNI EN 14411 (ISO 13006) Annex G-Group Bla

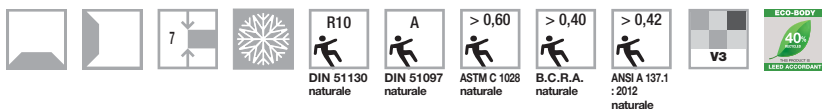



A horizontal band of a rich, textured brown color, resembling rust or aged leather. The texture is slightly grainy with some darker and lighter variations in tone.

**RUST**

A horizontal band of a very dark, almost black, textured color. It has a slightly grainy appearance with some subtle variations in the dark tones.

**DARK**

A horizontal band of a light, textured silver or grey color. The texture is soft and slightly grainy, with some darker and lighter variations in the silver tones.

**SILVER**

A horizontal band of a very light, textured off-white or cream color. The texture is soft and slightly grainy, with some darker and lighter variations in the off-white tones.

**PEARL**

# Interno 9

wall. INTERNO9 rust 160x320 - ALPES sand 160x320 floor. ALPES sand 160x320

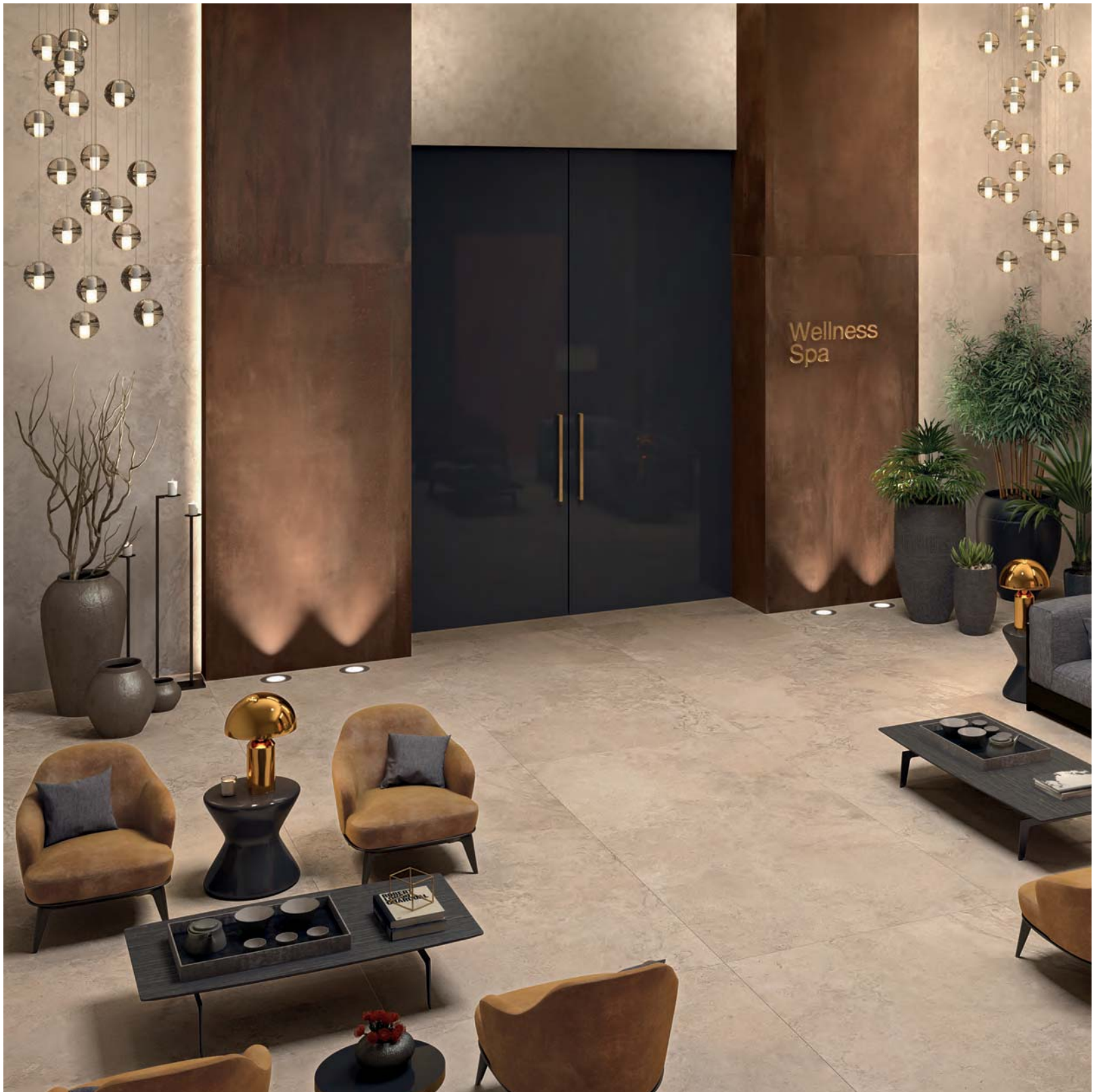



floor. dark 160x160



# Interno 9

wall. SENSI Onice beige LUX+ rett. 120x240 floor. Pearl rett. 120x120





floor. Silver rett. 120x240



# Interno 9

RUST

**WIDE**  
SUPERSIZE SLABS

7 mm  
▼  
▲

160x320 rett.	<b>0000299</b>	F 168,90
120x240 rett.	<b>0000311</b>	F 132,90
160x160 rett.	<b>0000302</b>	F 152,90
80x160 rett.	<b>0000305</b>	F 102,90
120x120 rett.	<b>0000314</b>	F 102,90
80x80 rett.	<b>0000308</b>	F 68,90

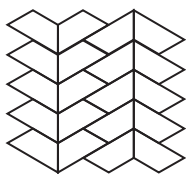



30x29  5  
MOS. VERSUS RUST  
**0000961** rett. F 252,90

BATTISCOPA rett.  
5,5x80  8 **0000720** PZ 8,90

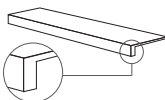

GRADONE TOP rett.  
32x120x4,5x1,5  1 **0000724** PZ 172,90



ANG. TOP SX rett.  
32x120x4,5x1,5  1 **0000763** PZ 198,90



ANG. TOP DX rett.  
32x120x4,5x1,5  1 **0000767** PZ 198,90



# Interno 9

DARK

**WIDE**  
SUPERSIZE SLABS

7 mm  
▲

160x320 rett.	<b>0000300</b>	F 168,90
120x240 rett.	<b>0000312</b>	F 132,90
160x160 rett.	<b>0000303</b>	F 152,90
80x160 rett.	<b>0000306</b>	F 102,90
120x120 rett.	<b>0000315</b>	F 102,90
80x80 rett.	<b>0000309</b>	F 68,90

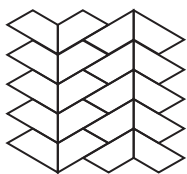



30x29  5  
MOS. VERSUS DARK  
**0000962** rett. F 252,90

BATTISCOPIA rett.  
5,5x80  8 **0000721** PZ 8,90

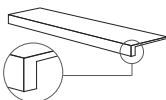

GRADONE TOP rett.  
32x120x4,5x1,5  1 **000725** PZ 172,90



ANG. TOP SX rett.  
32x120x4,5x1,5  1 **0000764** PZ 198,90



ANG. TOP DX rett.  
32x120x4,5x1,5  1 **0000768** PZ 198,90





# Interno 9

SILVER

**WIDE**  
SUPERSIZE SLABS

7 mm

160x320 rett.	<b>0000301</b>	F 168,90
120x240 rett.	<b>0000313</b>	F 132,90
160x160 rett.	<b>0000304</b>	F 152,90
80x160 rett.	<b>0000307</b>	F 102,90
120x120 rett.	<b>0000316</b>	F 102,90
80x80 rett.	<b>0000310</b>	F 68,90

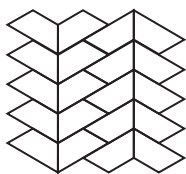

30x29  5  
MOS. VERSUS SILVER  
**0000963** rett. F 252,90

BATTISCOPA rett.  
5,5x80  8 **0000722** PZ 8,90



GRADONE TOP rett.  
32x120x4,5x1,5  1 **0000726** PZ 172,90

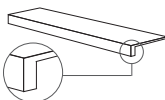

ANG. TOP SX rett.  
32x120x4,5x1,5  1 **0000765** PZ 198,90



ANG. TOP DX rett.  
32x120x4,5x1,5  1 **0000769** PZ 198,90





# Interno 9

PEARL

**WIDE**  
SUPERSIZE SLABS

7 mm

160x320 rett.	<b>0000625</b>	F 168,90
120x240 rett.	<b>0000629</b>	F 132,90
160x160 rett.	<b>0000626</b>	F 152,90
80x160 rett.	<b>0000627</b>	F 102,90
120x120 rett.	<b>0000630</b>	F 102,90
80x80 rett.	<b>0000628</b>	F 68,90

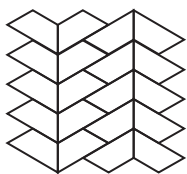



30x29  5  
MOS. VERSUS PEARL  
**0000964** rett. F 252,90

BATTISCOPIA rett.  
5,5x80  8 **0000723** PZ 8,90

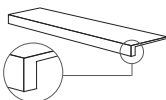

GRADONE TOP rett.  
32x120x4,5x1,5  1 **0000727** PZ 172,90



ANG. TOP SX rett.  
32x120x4,5x1,5  1 **0000766** PZ 198,90



ANG. TOP DX rett.  
32x120x4,5x1,5  1 **0000770** PZ 198,90



# Interno 9



0,5x120  4  
MATITA ALLUMINIO  
**0000086** PZ 20,90



0,5x120  4  
MATITA ALLUMINIO WHITE  
**0000087** PZ 34,90



0,5x120  4  
MATITA ALLUMINIO BLACK  
**0000088** PZ 34,90



0,5x120  4  
MATITA ALLUMINIO RAME  
**0000556** PZ 34,90



0,5x120  4  
MATITA ALLUMINIO BRONZO  
**0000557** PZ 34,90

wall. Silver rett. 80x160 - 120x240 - Matita Alluminio Rame 0,5x120 floor. Crossroad Wood Grey 20x120





# Interno 9

## IMBALLI/PACKAGING

F.to nominale Nominal size	F.to reale (mm) Real size (mm)	Spessore Thickness	Tipologia imballo Type of packing	Pz/Imballo Pcs/Packing	Pz/Scatola Pcs/Box	Mq/Scatola Sqm/Box	Kg/Scatola Kg/Box	Scatole/Imballo Box/Packing	Mq totali Sqm total	Kg/Imballo Kg/Packing	Kg totali Kg total	Prezzo imballo Packing Price
160x320 rett. 64"x128" rett.	1596,5x3195	7 mm	Cassa* Crate	11	-	-	-	-	56,32	139	1.125	€ 130,00
			Cavalletto container* Container Rack pallet	36	-	-	-	-	184,32	180	3.406	€ 235,00
120x240 rett. 48"x96" rett.	1194x2390	7 mm	Cavalletto* Rack pallet	40	-	-	-	-	115,20	100	2.116	€ 120,00
			Cavalletto container* Container Rack pallet	36	-	-	-	-	103,68	115	1.930	€ 190,00
160x160 rett. 64"x64" rett.	1596,5x1596,5	7 mm	Cassa* Crate	22	-	-	-	-	56,32	75	1.061	€ 90,00
			Cavalletto container* Container Rack pallet	36	-	-	-	-	92,16	95	1.708	€ 170,00
80x160 rett. 32"x64" rett.	797,25x1596,5	7 mm	Cavalletto* Rack pallet	56	2	2,56	44,80	28	71,68	70	1.325	€ 50,00
120x120 rett. 48"x48" rett.	1194x1194	7 mm	Cavalletto* Rack pallet	56	2	2,88	50,40	28	80,64	70	1.482	€ 50,00
80x80 rett. 32"x32" rett.	797,25x797,25	7 mm	Europallet*	120	3	1,92	33,60	40	76,80	15	1.359	-

\* Approfondimenti sugli imballi a pag. 378 dell' area tecnica. / Details concerning packaging available at page 378 inside technical area.

L'unità minima di vendita per tutti gli articoli (fondi, decori e pezzi speciali) è la scatola completa. / The minimum sales quantity for all items (plain tiles, decorations and special trims) is one full box. I dati relativi agli imballi sono aggiornati al momento della stampa del catalogo e pertanto possono subire variazioni nel corso del tempo. / Data referring to packaging have been update at time of printing; the actual data may be slightly different. Pezzi speciali e decori per effetto delle lavorazioni, possono presentare variazioni di tonalità. / Due to working process special trims and decors, may show variation in tonality.

	SIGILLANTI COORDINATI PER FUGHE / COORDINATED GROUT SEALANTS			COLLANTI / ADHESIVES	
	INTERNO 9	COLORE SIGILLANTE SEALANT COLOUR	CODICE SIGILLANTE SEALANT CODE		
	Interno 9 Dune		SI123B kromos manhattan		
	Interno 9 Rust		SI155B kromos noce		
	Interno 9 Rust		SI152B kromos ardesia		
	Interno 9 Mud / Silver		SI121B kromos cemento		
	Interno 9 Dark		SI122B kromos antracite	Baulite S2 Bianco AD340M	+30 Bianco AD330M
	Interno 9 Pearl		SI120B kromos grigio luce	Baulite S2 Grigio AD341M	+30 Grigio AD331M

Per una migliore resa estetica e tecnica ABK consiglia l'utilizzo di sigillanti e collanti HARDKOLL come da tabella. Per listino, scheda tecnica e approfondimenti vedi pag. 370  
ABK suggests Hardkoll sealants and adhesives for a better aesthetics and technical efficiency, as follow. Read more at page 370 for prices and technical data sheets.

# Interno 9

---

## GRES PORCELLANATO A MASSA COLORATA

FULL BODY COLORED PORCELAIN STONEWARE

## SUPERFICI SURFACES

naturale - natural  
lappato - honed

## FORMATI SIZES



60x120  
24"x 48"



60x120  
mix sizes  
24"x 48"



30x120  
12"x 48"



60x60  
24"x 24"



30x60  
12"x 24"

▼  
9 mm  
▲

---

Classificazione secondo norme UNI EN 14411 (ISO 13006) Allegato G Gruppo Bla  
Classification in accordance with UNI EN 14411 (ISO 13006) Annex G-Group Bla



R10  
DIN 51130  
naturale



A+B  
DIN 51097  
naturale



> 0,60  
ASTM C 1028  
naturale



> 0,40  
B.C.R.A.  
naturale



> 0,42  
ANSI A 137.1  
:2012  
naturale



V3



Eco-BODY  
40%  
RECYCLED CONTENT  
LEED ACCORDANT



**RUST**

A horizontal band showing a dark, mottled brown texture with variations in tone and some darker spots, resembling rust on a metal surface.

**MUD**

A horizontal band showing a dark, earthy brown texture with a slightly grainy and uneven appearance, resembling mud.

**DUNE**

A horizontal band showing a light, sandy beige texture with subtle variations in tone and a slightly grainy appearance, resembling sand dunes.

**DARK**

A horizontal band showing a very dark, almost black, textured surface with some subtle variations in tone, resembling a dark, possibly metallic or stone, surface.

**SILVER**

A horizontal band showing a light, metallic silver texture with a grainy, crystalline appearance, resembling silver metal.

**PEARL**

A horizontal band showing a light, iridescent, and shimmering texture with subtle variations in tone, resembling the surface of a pearl.



# Interno 9

floor. dune 60x120



wall. rust 60x120





# Interno 9

indoor. pearl 30x120 outdoor. dolphin grey aged 20x120





**wall.** dark 60x120 **floor.** mud lapp. 60x120



# Interno 9

RUST



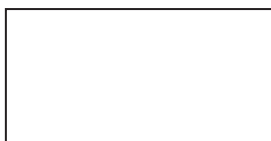





60x120  2  
 INTERNO 9 RUST  
**I9R34300** rett. F 68,90  
**I9L34300** lapp rett. F 81,90

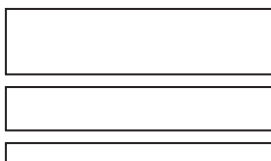

30x60  4  
 MOS. LOSANGA RUST  
**I9R03301** rett. F 119,90



60x120  2  
 INTERNO 9 RUST  
**I9R34310** mix sizes rett. F 88,90  
 Pcs/box: 30x120  2  
 20x120  2  
 10x120  2



30x30  6  
 MOS. QUADRETTI RUST  
**I9R09301** rett. F 101,90



30x120  4  
 INTERNO 9 RUST  
**I9R57300** rett. F 68,90  
**I9L57300** lapp. rett. F 81,90



60x60  3  
 INTERNO 9 RUST  
**I9R01300** rett. F 53,90  
**I9L01300** lapp. rett. F 64,90



30x60  6  
 INTERNO 9 RUST  
**I9R03300** rett. F 49,90



30x120  2  
 FASCIA RAKU DARK MIX 2  
**I9R57051** (prezzo al pz) PZ 149,90  
 (Metalli preziosi - Precious metals)



19,5x8,5  4  
 LOSANGA RAKU MIX  
**I9R03052** PZ 25,90



5x30  4  
 \* FASCIA ESSENZE MIX  
**I9R03053** PZ 21,90  
 (Legno - Wood)



4x30  4  
 \* FASCIA ARDESIA GRIGIO  
**RER09204** rett. PZ 20,90  
 (Pietra naturale - Natural stone)



4x30  4  
 \* FASCIA ARDESIA BRONZO  
**RER09054** rett. PZ 20,90  
 (Pietra naturale - Natural stone)

0,5x120  4  
 MATITA ALLUMINIO  
**0000086** PZ 20,90

0,5x120  4  
 MATITA ALLUMINIO WHITE  
**0000087** PZ 34,90

0,5x120  4  
 MATITA ALLUMINIO BLACK  
**0000088** PZ 34,90

0,5x120  4  
 MATITA ALLUMINIO RAME  
**0000556** PZ 34,90

0,5x120  4  
 MATITA ALLUMINIO BRONZO  
**0000557** PZ 34,90

\* Art. realizzati con materiali naturali:  
 vedi indicazioni per posa e pulizia a pag. 393 dell' area tecnica.  
 \* Items produced with natural materials:  
 check the technical area at page 393.



# Interno 9

MUD



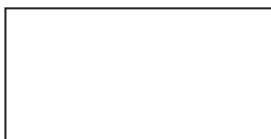



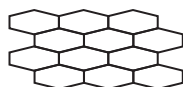

60x120  2  
 INTERNO 9 MUD  
**I9R34250** rett. F 68,90  
**I9L34250** lapp rett. F 81,90

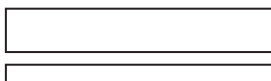

30x60  4  
 MOS. LOSANGA MUD  
**I9R03251** rett. F 119,90



60x120  2  
 INTERNO 9 MUD  
**I9R34260** mix sizes rett. F 88,90

Pcs/box: 30x120  2  
 20x120  2  
 10x120  2



30x30  6  
 MOS. QUADRETTI MUD  
**I9R09251** rett. F 101,90



60x120  4  
 INTERNO 9 MUD  
**I9R57250** rett. F 68,90  
**I9L57250** lapp. rett. F 81,90



60x60  3  
 INTERNO 9 MUD  
**I9R01250** rett. F 53,90  
**I9L01250** lapp. rett. F 64,90



30x60  6  
 INTERNO 9 MUD  
**I9R03250** rett. F 49,90



60x60  3  
 DUO INTERNO 9 HOT  
**I9R01260** rett. F 64,90



5x30  4  
 \* FASCIA ESSENZE MIX  
**I9R03053** PZ 21,90  
 (Legno - Wood)



4x30  4  
 \* FASCIA ARDESIA GRIGIO  
**RER09204** rett. PZ 20,90  
 (Pietra naturale - Natural stone)



4x30  4  
 \* FASCIA ARDESIA BRONZO  
**RER09054** rett. PZ 20,90  
 (Pietra naturale - Natural stone)

0,5x120  4  
 MATITA ALLUMINIO  
**0000086** PZ 20,90

0,5x120  4  
 MATITA ALLUMINIO WHITE  
**0000087** PZ 34,90

0,5x120  4  
 MATITA ALLUMINIO BLACK  
**0000088** PZ 34,90

0,5x120  4  
 MATITA ALLUMINIO RAME  
**0000556** PZ 34,90

0,5x120  4  
 MATITA ALLUMINIO BRONZO  
**0000557** PZ 34,90

\* Art. realizzati con materiali naturali:  
 vedi indicazioni per posa e pulizia a  
 pag. 393 dell' area tecnica.  
 \* Items produced with natural materials:  
 check the technical area on page 393.

# Interno 9

DUNE



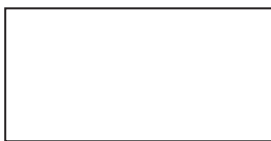

60x120 ☞ 2  
 INTERNO 9 DUNE  
**I9R34100** rett. F 68,90  
**I9L34100** lapp. rett. F 81,90



30x60 ☞ 4  
 MOS. LOSANGA DUNE  
**I9R03101** rett. F 119,90

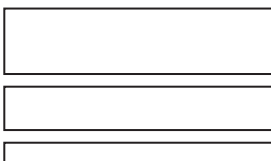

60x120 ☞ 2  
 INTERNO 9 DUNE  
**I9R34110** mix sizes rett. F 88,90



30x30 ☞ 6  
 MOS. QUADRETTI DUNE  
**I9R09101** rett. F 101,90

Pcs./box: 30x120 ☞ 2  
 20x120 ☞ 2  
 10x120 ☞ 2



30x120 ☞ 4  
 INTERNO 9 DUNE  
**I9R57100** rett. F 68,90  
**I9L57100** lapp. rett. F 81,90



60x60 ☞ 3  
 INTERNO 9 DUNE  
**I9R01100** rett. F 53,90  
**I9L01100** lapp. rett. F 64,90



30x60 ☞ 6  
 INTERNO 9 DUNE  
**I9R03100** rett. F 49,90



30x120 ☞ 2  
 FASCIA RAKU LIGHT MIX 2  
**I9R57052** (prezzo al pz) PZ 149,90  
 (Metalli preziosi - Precious metals)



19,5x8,5 ☞ 4  
 LOSANGA RAKU MIX  
**I9R03052** PZ 25,90



5x30 ☞ 4  
 \* FASCIA ESSENZE MIX  
**I9R03053** PZ 21,90  
 (Legno - Wood)



4x30 ☞ 4  
 \* FASCIA ARDESIA GRIGIO  
**RER09204** rett. PZ 20,90  
 (Pietra naturale - Natural stone)



4x30 ☞ 4  
 \* FASCIA ARDESIA BRONZO  
**RER09054** rett. PZ 20,90  
 (Pietra naturale - Natural stone)



0,5x120 ☞ 4  
 MATITA ALLUMINIO  
**0000086** PZ 20,90



0,5x120 ☞ 4  
 MATITA ALLUMINIO WHITE  
**0000087** PZ 34,90



0,5x120 ☞ 4  
 MATITA ALLUMINIO BLACK  
**0000088** PZ 34,90



0,5x120 ☞ 4  
 MATITA ALLUMINIO RAME  
**0000556** PZ 34,90



0,5x120 ☞ 4  
 MATITA ALLUMINIO BRONZO  
**0000557** PZ 34,90

\* Art. realizzati con materiali naturali:  
 vedi indicazioni per posa e pulizia a pag. 393 dell' area tecnica.  
 \* Items produced with natural materials:  
 check the technical area at page 393.

# Interno 9

DARK







60x120 2  
 INTERNO 9 DARK  
**I9R34200** rett. F 68,90  
**I9L34200** lapp. rett. F 81,90

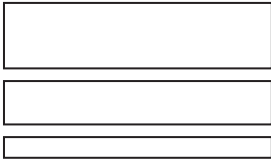

60x120 2  
 INTERNO 9 DARK  
**I9R34210** mix sizes rett. F 88,90  
 Pcs./box: 30x120 2  
 20x120 2  
 10x120 2

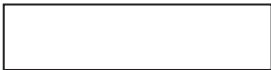

30x120 4  
 INTERNO 9 DARK  
**I9R57200** rett. F 68,90  
**I9L57200** lapp. rett. F 81,90



60x60 3  
 INTERNO 9 DARK  
**I9R01200** rett. F 53,90  
**I9L01200** lapp. rett. F 64,90



30x60 6  
 INTERNO 9 DARK  
**I9R03200** rett. F 49,90



30x60 4  
 MOS. LOSANGA DARK  
**I9R03201** rett. F 119,90



30x30 6  
 MOS. QUADRETTI DARK  
**I9R09201** rett. F 101,90



30x120 2  
 FASCIA RAKU DARK MIX 2  
**I9R57051** (prezzo al pz) PZ 149,90  
 (Metalli preziosi - Precious metals)



19,5x8,5 4  
 LOSANGA RAKU MIX  
**I9R03052** PZ 25,90



5x30 4  
 \* FASCIA ESSENZE MIX  
**I9R03053** PZ 21,90  
 (Legno - Wood)



4x30 4  
 \* FASCIA ARDESIA GRIGIO  
**RER09204** rett. PZ 20,90  
 (Pietra naturale - Natural stone)



4x30 4  
 \* FASCIA ARDESIA BRONZO  
**RER09054** rett. PZ 20,90  
 (Pietra naturale - Natural stone)



0,5x120 4  
 MATITA ALLUMINIO  
**0000086** PZ 20,90

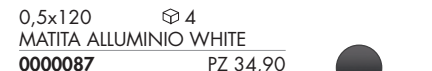

0,5x120 4  
 MATITA ALLUMINIO WHITE  
**0000087** PZ 34,90



0,5x120 4  
 MATITA ALLUMINIO BLACK  
**0000088** PZ 34,90

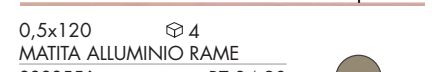

0,5x120 4  
 MATITA ALLUMINIO RAME  
**0000556** PZ 34,90



0,5x120 4  
 MATITA ALLUMINIO BRONZO  
**0000557** PZ 34,90

\* Art. realizzati con materiali naturali:  
 vedi indicazioni per posa e pulizia a pag. 393 dell' area tecnica.  
 \* Items produced with natural materials:  
 check the technical area at page 393.

# Interno 9



SILVER

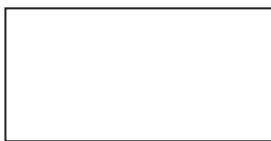

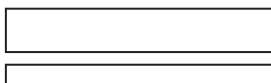

60x120  2  
 INTERNO 9 SILVER  
**I9R34150** rett. F 68,90  
**I9L34150** lapp rett. F 81,90



60x120  2  
 INTERNO 9 SILVER  
**I9R34160** mix sizes rett. F 88,90  
 Pcs/box: 30x120  2  
 20x120  2  
 10x120  2



60x120  4  
 INTERNO 9 SILVER  
**I9R57150** rett. F 68,90  
**I9L57150** lapp. rett. F 81,90

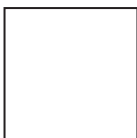

60x60  3  
 INTERNO 9 SILVER  
**I9R01150** rett. F 53,90  
**I9L01150** lapp. rett. F 64,90



30x60  6  
 INTERNO 9 SILVER  
**I9R03150** rett. F 49,90

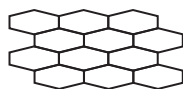

30x60  4  
 MOS. LOSANGA SILVER  
**I9R03151** rett. F 119,90



30x30  6  
 MOS. QUADRETTI SILVER  
**I9R09151** rett. F 101,90



60x60  3  
 DUO INTERNO 9 COLD  
**I9R01160** rett. F 64,90



5x30  4  
 \* FASCIA ESSENZE MIX  
**I9R03053** PZ 21,90  
 (Legno - Wood)



4x30  4  
 \* FASCIA ARDESIA GRIGIO  
**RER09204** rett. PZ 20,90  
 (Pietra naturale - Natural stone)

0,5x120  4  
 MATITA ALLUMINIO  
**0000086** PZ 20,90

0,5x120  4  
 MATITA ALLUMINIO WHITE  
**0000087** PZ 34,90

0,5x120  4  
 MATITA ALLUMINIO BLACK  
**0000088** PZ 34,90

0,5x120  4  
 MATITA ALLUMINIO RAME  
**0000556** PZ 34,90

0,5x120  4  
 MATITA ALLUMINIO BRONZO  
**0000557** PZ 34,90

\* Art. realizzati con materiali naturali:  
 vedi indicazioni per posa e pulizia a  
 pag. 393 dell' area tecnica.  
 \* Items produced with natural materials:  
 check the technical area on page 393.

# Interno 9

PEARL





60x120 ☞ 2  
 INTERNO 9 PEARL  
**I9R34050** rett. F 68,90  
**I9L34050** lapp rett. F 81,90

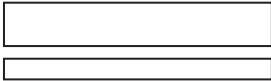

60x120 ☞ 2  
 INTERNO 9 PEARL  
**I9R34060** mix sizes rett. F 88,90  
 Pcs./box: 30x120 ☞ 2  
20x120 ☞ 2  
10x120 ☞ 2



30x120 ☞ 4  
 INTERNO 9 PEARL  
**I9R57050** rett. F 68,90  
**I9L57050** lapp. rett. F 81,90



60x60 ☞ 3  
 INTERNO 9 PEARL  
**I9R01050** rett. F 53,90  
**I9L01050** lapp. rett. F 64,90

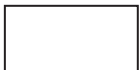

30x60 ☞ 6  
 INTERNO 9 PEARL  
**I9R03050** rett. F 49,90



30x60 ☞ 4  
 MOS. LOSANGA PEARL  
**I9R03051** rett. F 119,90



30x30 ☞ 6  
 MOS. QUADRETTI PEARL  
**I9R09051** rett. F 101,90



30x120 ☞ 2  
 FASCIA RAKU LIGHT MIX 2  
**I9R57052** (prezzo al pz) PZ 149,90  
 (Metalli preziosi - Precious metals)



19,5x8,5 ☞ 4  
 LOSANGA RAKU MIX  
**I9R03052** PZ 25,90



5x30 ☞ 4  
 \* FASCIA ESSENZE MIX  
**I9R03053** PZ 21,90  
 (Legno - Wood)



4x30 ☞ 4  
 \* FASCIA ARDESIA GRIGIO  
**RER09204** rett. PZ 20,90  
 (Pietra naturale - Natural stone)



4x30 ☞ 4  
 \* FASCIA ARDESIA BRONZO  
**RER09054** rett. PZ 20,90  
 (Pietra naturale - Natural stone)



0,5x120 ☞ 4  
 MATITA ALLUMINIO  
**0000086** PZ 20,90

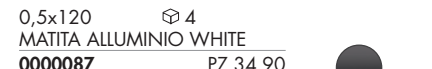

0,5x120 ☞ 4  
 MATITA ALLUMINIO WHITE  
**0000087** PZ 34,90

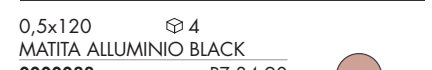

0,5x120 ☞ 4  
 MATITA ALLUMINIO BLACK  
**0000088** PZ 34,90



0,5x120 ☞ 4  
 MATITA ALLUMINIO RAME  
**0000556** PZ 34,90

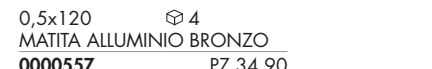

0,5x120 ☞ 4  
 MATITA ALLUMINIO BRONZO  
**0000557** PZ 34,90

\* Art. realizzati con materiali naturali:  
 vedi indicazioni per posa e pulizia a pag. 393 dell' area tecnica.  
 \* Items produced with natural materials:  
 check the technical area at page 393.



# Interno 9

floor. Dark 60x120 - Gradone Top Dark 32x120x4,5x2

## PEZZI SPECIALI / SPECIAL TRIMS

							
		RUST	MUD	DUNE	DARK	SILVER	PEARL
	BATTISCOPA rett. 5,5x60 PZ 7,90  10	I9R01302	I9R01252	I9R01102	I9R01202	I9R01152	I9R01052
	GRADONE TOP rett. 32x120x4,5x2 PZ 172,90  1	I9R34301	I9R34251	I9R34101	I9R34201	I9R34151	I9R34051
	ANGOLARE TOP SX 32x120x4,5x2 PZ 198,90  1	I9R34302	I9R34252	I9R34102	I9R34202	I9R34152	I9R34052
	ANGOLARE TOP DX 32x120x4,5x2 PZ 198,90  1	I9R34303	I9R34253	I9R34103	I9R34203	I9R34153	I9R34053



# Interno 9

## IMBALLI/PACKAGING

F.to nominale Nominal size	F.to reale (mm) Real size (mm)	Spessore Thickness	Pz/Scatola Pcs/Box	Mq/Scatola Sqm/Box	Kg/Scatola Kg/Box	Scatole/Imballo Box/Packing	Mq totali Sqm total	Kg totali Kg total
60x120 / 24"x48" rett.	596x1194	9 mm	2	1,44	27,20	26	37,44	748
60x120 mix sizes	596x1194	9 mm	2	1,44	27,20	26	37,44	748
30x120 / 12"x48" rett.	297x1194	9 mm	4	1,44	27,20	18	25,92	509
*60x60 / 24"x24" rett.	596x596	9 mm	3	1,08	21,20	40	43,20	868
*30x60 / 12"x24" rett.	297x596	9 mm	6	1,08	21,20	40	43,20	868

L'unità minima di vendita per tutti gli articoli (fondi, decori e pezzi speciali) è la scatola completa. / The minimum sales quantity for all items (plain tiles, decorations and special trims) is one full box. / I dati relativi agli imballi sono aggiornati al momento della stampa del catalogo e pertanto possono subire variazioni nel corso del tempo. /

Data referring to packaging have been update at time of printing; the actual data may be slightly different.

Pezzi speciali e decori per effetto delle lavorazioni, possono presentare variazioni di tonalità. / Due to working process special trims and decors, may show variation in tonality.

### SIGILLANTI COORDINATI PER FUGHE / COORDINATED GROUT SEALANTS

INTERNO 9	COLORE SIGILLANTE SEALANT COLOUR	CODICE SIGILLANTE SEALANT CODE
Interno 9 Dune		SI123B kromos manhattan
Interno 9 Rust		SI155B kromos noce
Interno 9 Rust		SI152B kromos ardesia
Interno 9 Mud / Silver		SI121B kromos cemento
Interno 9 Dark		SI122B kromos antracite
Interno 9 Pearl		SI120B kromos grigio luce

### COLLANTI / ADHESIVES



\*Vedi tabella imballi /  
\*See at packaging list

Bauflex Bianco AD200M

Bauflex Grigio AD210M



+30 Bianco AD330M

+30 Grigio AD331M

**HARDKOLL**  
LIVING INNOVATIONS

Per una migliore resa estetica e tecnica ABK consiglia l'utilizzo di sigillanti e collanti HARDKOLL come da tabella. Per listino, scheda tecnica e approfondimenti vedi pag. 370  
ABK suggests Hardkoll sealants and adhesives for a better aesthetics and technical efficiency, as follow. Read more at page 370 for prices and technical data sheets.

# Downtown

---

## GRES PORCELLANATO A MASSA COLORATA

FULL BODY COLORED PORCELAIN STONEWARE

## SUPERFICI SURFACES

naturale - natural

lappato - honed

walk R11 - structured R11

## FORMATI SIZES



80x80  
32"x 32"



40x80  
16"x 32"



20x80  
8"x 32"



60x60  
24"x 24"



30x60  
12"x 24"



30x30  
12"x 12"



11 mm



9 mm

---

Classificazione secondo norme UNI EN 14411 (ISO 13006) Allegato G Gruppo B1a

Classification in accordance with UNI EN 14411 (ISO 13006) Annex G-Group B1a



80x80



9



R9

DIN 51130  
naturale



DIN 51130  
walk



DIN 51097  
naturale



DIN 51097  
walk



ASTM C 1028  
naturale/  
walk



B.C.R.A.  
naturale/  
walk



ANSI A 137.1  
:2102  
naturale/  
bocciardato



V3



Eco-body  
40%  
LEED ACCORDANT





**IVORY**

**ECRÜ**

**EARTH**

**ASH**

**GRAPHITE**



# Downtown

floor. downtown graphite rett. 80x80

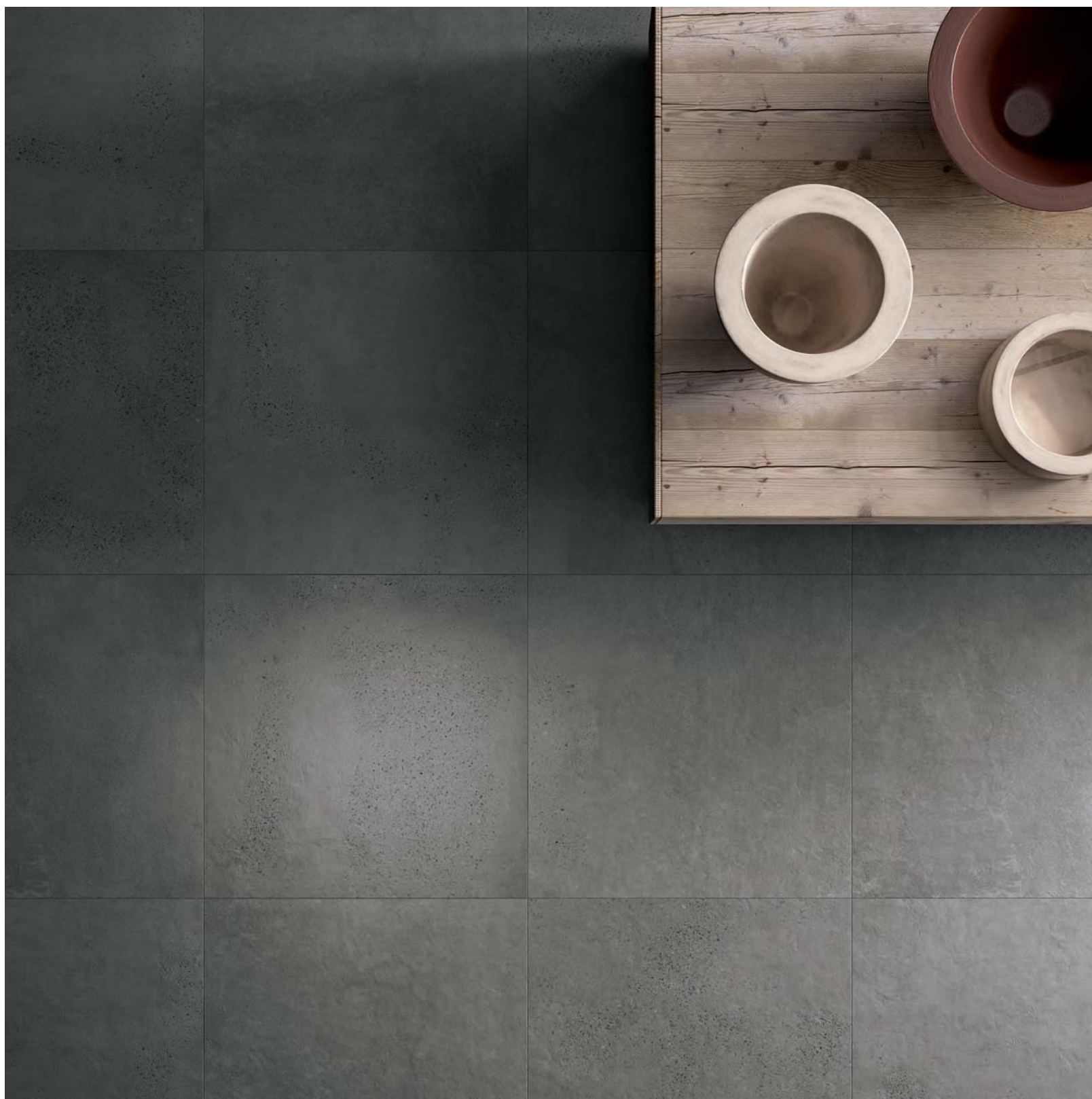

floor. ash lapp. rett. 80x80 wall. 40x80





# Downtown

IVORY



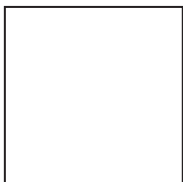

80x80 2  
DOWNTOWN IVORY

**DWR52050** rett. F 68,90  
**DWL52050** lapp. rett. F 81,90

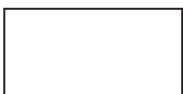

40x80 3  
DOWNTOWN IVORY

**DWR51050** rett. F 53,90  
**DWL51050** lapp. rett. F 64,90

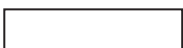

20x80 8  
DOWNTOWN IVORY

**DWR4905B** rett. F 58,90

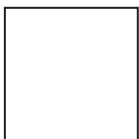

60x60 3  
DOWNTOWN IVORY

**DWN01050** nat. F 46,90  
**DWR01050** rett. F 53,90  
**DWL01050** lapp. rett. F 64,90



30x60 6  
DOWNTOWN IVORY

**DWR03050** rett. F 49,90  
**DWL03050** lapp. rett. F 59,90



30x30 12  
DOWNTOWN IVORY

**DWR09050** rett. F 53,90



30x30 6  
MOSAICO QUADRETTI IVORY

**DWR09051** rett. F 101,90  
**DWR03500** walk F 101,90

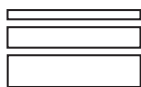

Pcs/Box:  
5x60 6  
10x60 6  
15x60 6

30x60 6  
DOWNTOWN IVORY  
**DWR00050** mix sizes rett. F 74,90



30x40 4  
MOSAICO BRICK IVORY/ASH

**DWR51051** rett. PZ 21,90  
**DWL51051** lappato PZ 21,90  
(Miscelazione colori casuale - Random mixing colours)

OUTDOOR **R11** 9 mm



30x60 6  
DOWNTOWN IVORY  
**DWN03500** walk nat. F 38,90

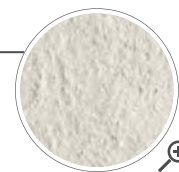

# Downtown

ECRU

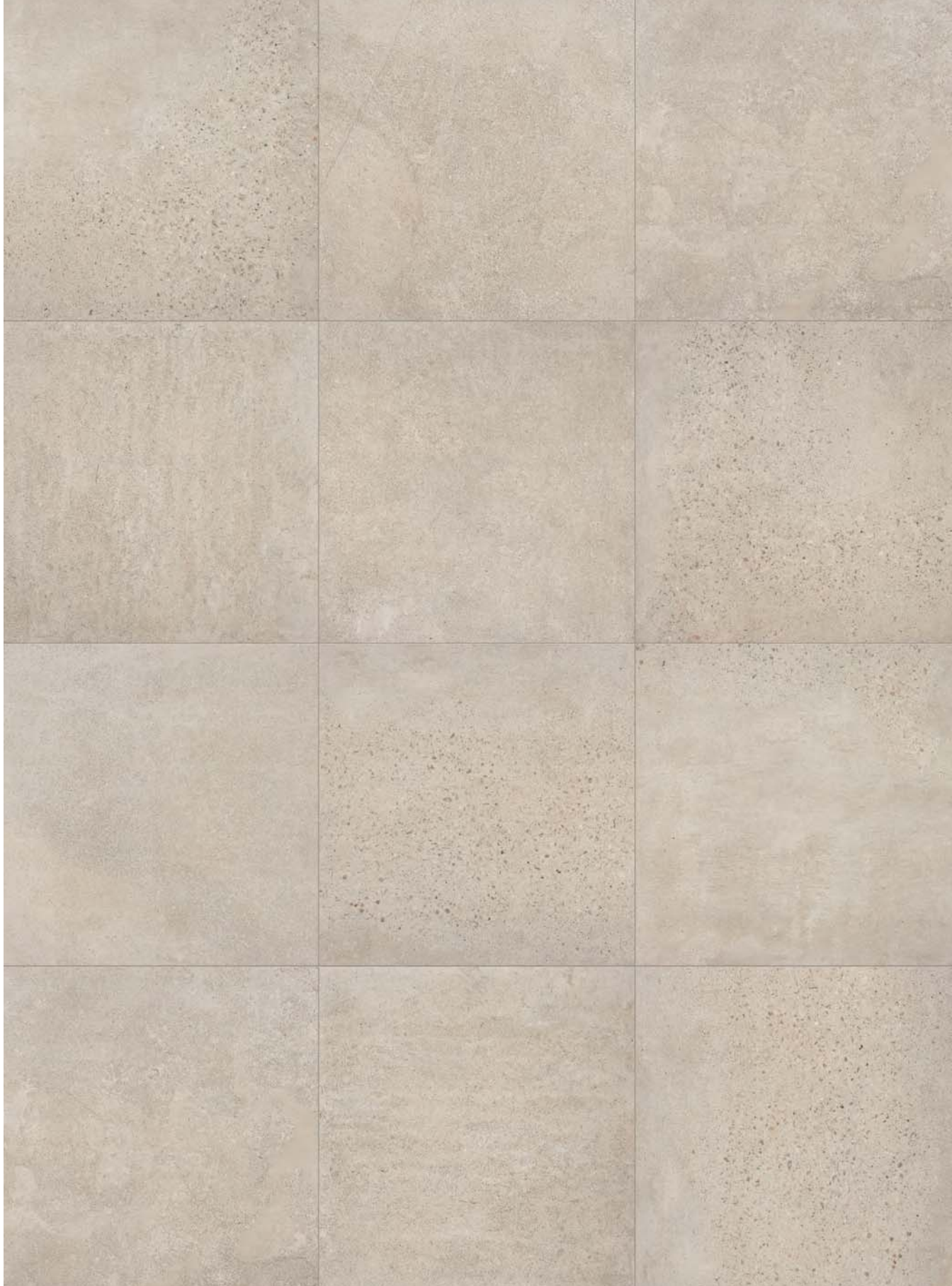



40x80  3  
 DOWNTOWN ECRU  
**DWR51000** rett. F 53,90  
**DWL51000** lapp. rett. F 64,90

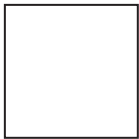

60x60  3  
 DOWNTOWN ECRU  
**DWN01100** nat. F 46,90  
**DWR01100** rett. F 53,90  
**DWL01100** lapp. rett. F 64,90



30x60  6  
 DOWNTOWN ECRU  
**DWR03100** rett. F 49,90  
**DWL03100** lapp. rett. F 59,90







30x30  12  
 DOWNTOWN ECRU  
**DWR09100** rett. F 53,90

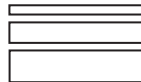

30x30  6  
 MOSAICO QUADRETTI ECRU  
**DWR09101** rett. F 101,90



Pcs/Box  
 5x60  6  
 10x60  6  
 15x60  6  
 30x60  6  
 DOWNTOWN ECRU MIX SIZES  
**DWR00100** rett. F 74,90



30x40  4  
 MOSAICO BRICK ECRU/EARTH  
**DWR51001** rett. PZ 21,90  
**DWL51001** lappato PZ 21,90  
 (Miscelazione colori casuale - Random mixing colours)



5x80  4  
 LIST. SOLERAS AVANA  
**S1R49255** rett. PZ 6,90



# Downtown

EARTH

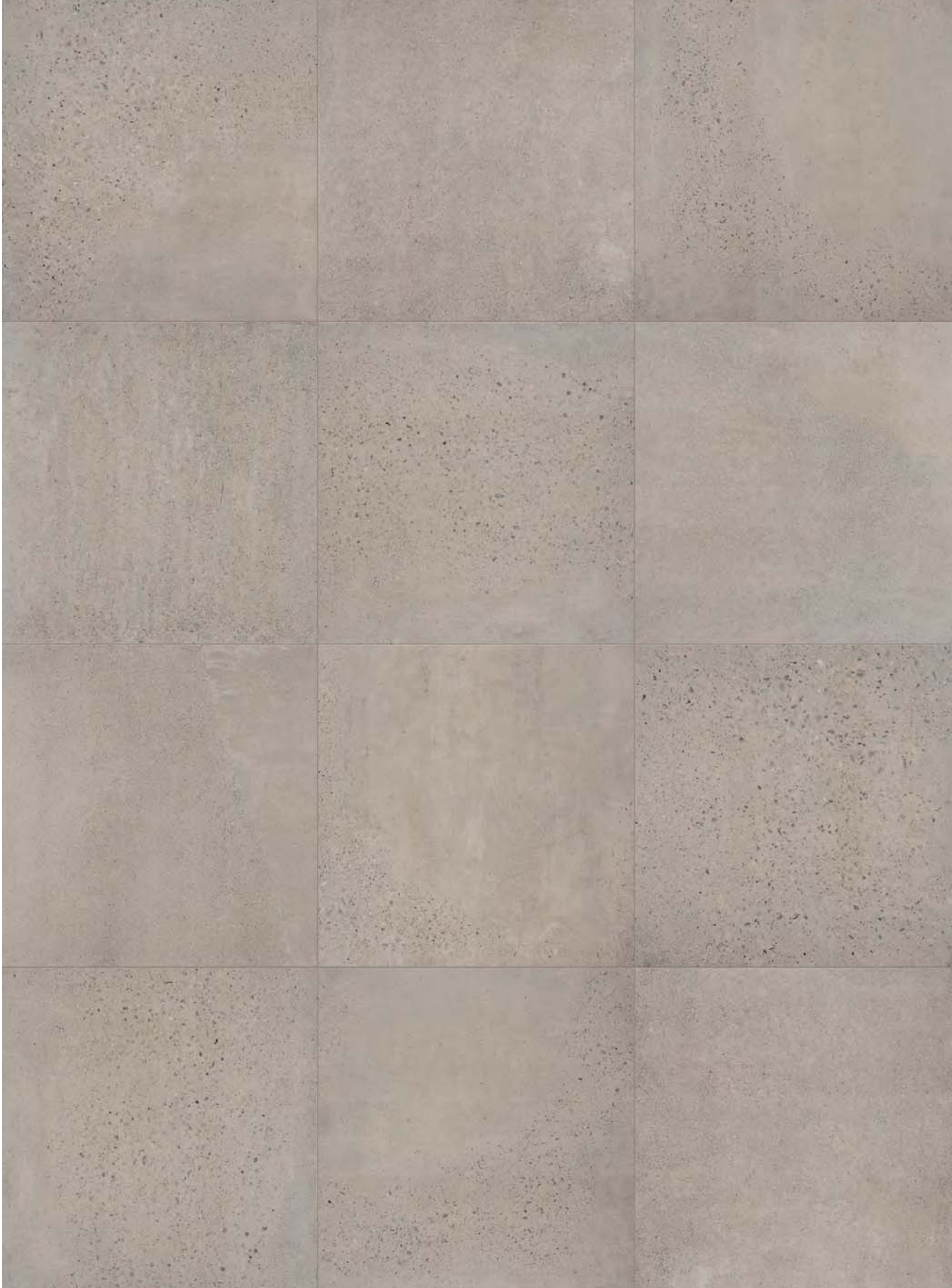





40x80 3  
 DOWNTOWN EARTH  
**DWR51150** rett. F 53,90  
**DWL51150** lapp. rett. F 64,90

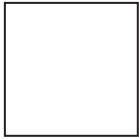

60x60 3  
 DOWNTOWN EARTH  
**DWN01150** nat. F 46,90  
**DWR01150** rett. F 53,90  
**DWL01150** lapp. rett. F 64,90



30x60 6  
 DOWNTOWN EARTH  
**DWR03150** rett. F 49,90  
**DWL03150** lapp. rett. F 59,90



30x30 12  
 DOWNTOWN EARTH  
**DWR09150** rett. F 53,90



30x30 6  
 MOSAICO QUADRETTI EARTH  
**DWR09151** rett. F 101,90  
**DWR03550** walk F 101,90

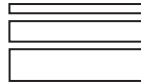

Pcs/Box  
 5x60 6  
 10x60 6  
 15x60 6  
 30x60 6  
 DOWNTOWN EARTH MIX SIZES  
**DWR00150** rett. F 74,90



30x40 4  
 MOSAICO BRICK ECRU/EARTH  
**DWR51001** rett. PZ 21,90  
**DWL51001** lappato PZ 21,90  
 (Miscelazione colori casuale - Random mixing colours)

OUTDOOR 9 mm



30x60 6  
 DOWNTOWN EARTH  
**DWN03550** walk nat. F 38,90

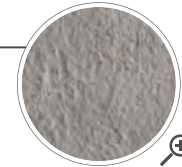

# Downtown

ASH

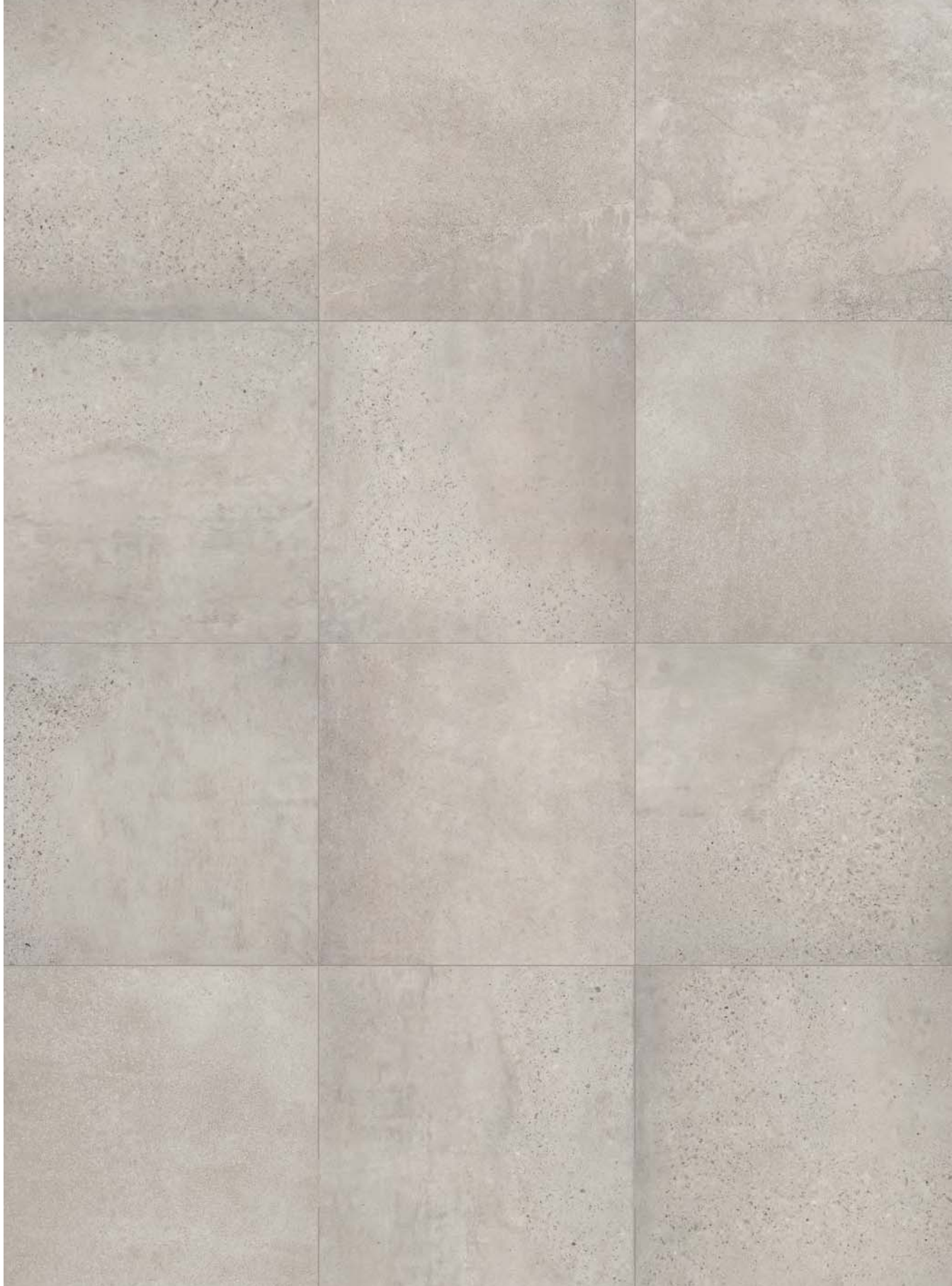

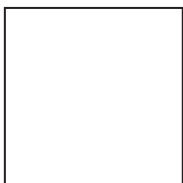

80x80 ☞ 2  
DOWNTOWN ASH  
**DWR52200** rett. F 68,90  
**DWL52200** lapp. rett. F 81,90

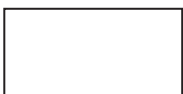

40x80 ☞ 3  
DOWNTOWN ASH  
**DWR51200** rett. F 53,90  
**DWL51200** lapp. rett. F 64,90



20x80 ☞ 8  
DOWNTOWN ASH  
**DWR4920B** rett. F 58,90

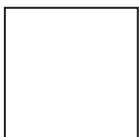

60x60 ☞ 3  
DOWNTOWN ASH  
**DWN01200** nat. F 46,90  
**DWR01200** rett. F 53,90  
**DWL01200** lapp. rett. F 64,90



30x60 ☞ 6  
DOWNTOWN ASH  
**DWR03200** rett. F 49,90  
**DWL03200** lapp. rett. F 59,90





30x30 ☞ 12  
DOWNTOWN ASH  
**DWR09200** rett. F 53,90



30x30 ☞ 6  
MOSAICO QUADRETTI ASH  
**DWR09201** rett. F 101,90  
**DWR03600** walk F 101,90



	Pcs/Box
	5x60 ☞ 6
	10x60 ☞ 6
	15x60 ☞ 6

30x60 ☞ 6  
DOWNTOWN ASH MIX SIZES  
**DWR00200** rett. F 74,90



30x40 ☞ 4  
MOSAICO BRICK IVORY/ASH  
**DWR51051** rett. PZ 21,90  
**DWL51051** lappato PZ 21,90  
(Miscelazione colori casuale - Random mixing colours)



30x60 ☞ 2  
DEC. ONE WAY ARROW ASH  
**DWR03201** rett. PZ 44,90



30x60 ☞ 2  
DEC. ONE WAY LINE ASH  
**DWR03202** rett. PZ 44,90



5x80 ☞ 4  
LIST. SOLERAS ANTRACITE  
**S1R49155** rett. PZ 6,90

**OUTDOOR** R11 



30x60 ☞ 6  
DOWNTOWN ASH  
**DWN03600** walk nat. F 38,90



# Downtown

GRAPHITE

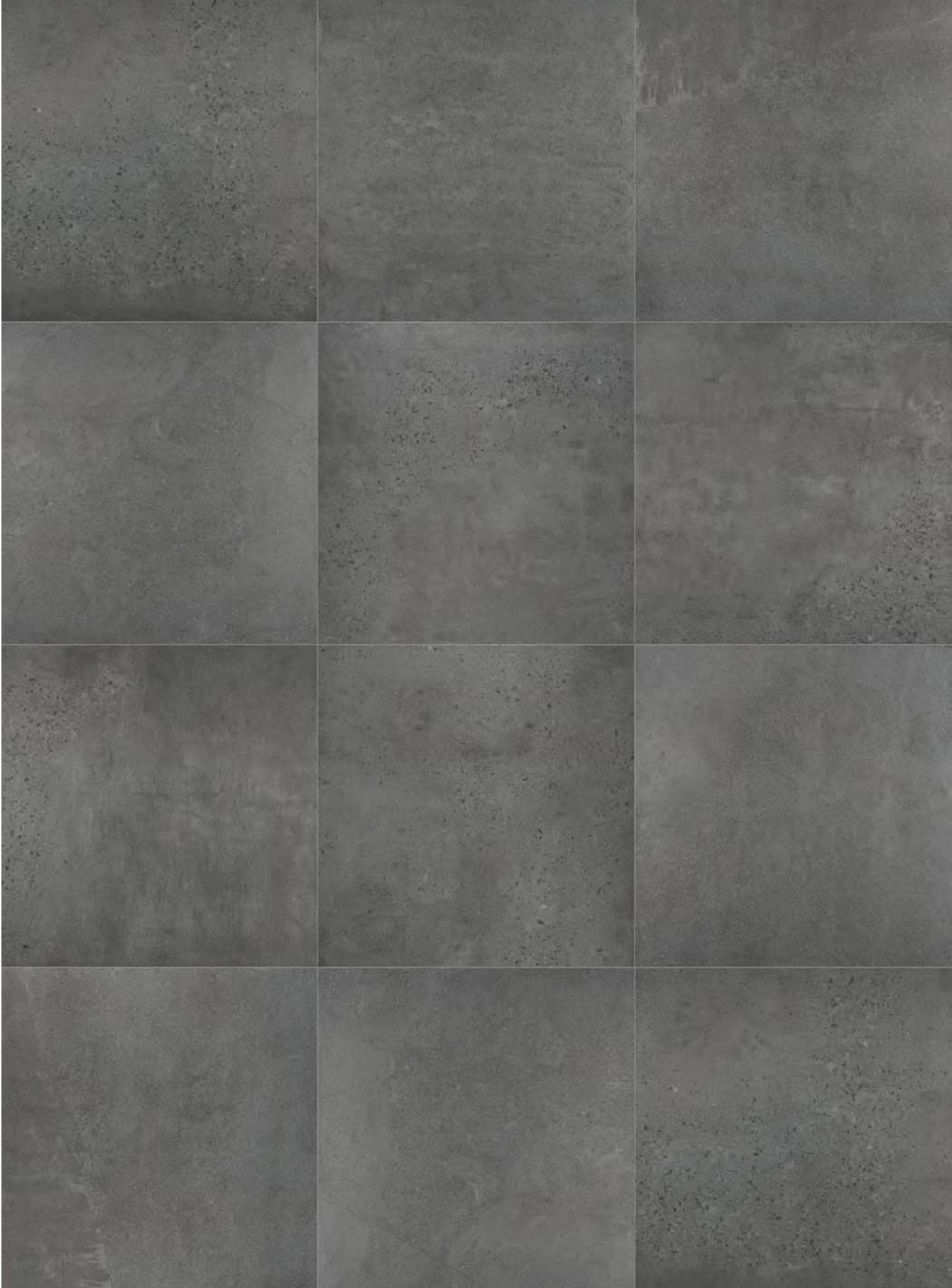

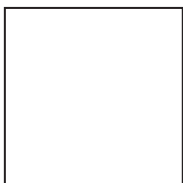

80x80 2  
DOWNTOWN GRAPHITE

**DWR52250** rett. F 68,90  
**DWL52250** lapp. rett. F 81,90

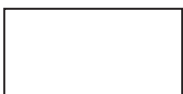

40x80 3  
DOWNTOWN GRAPHITE

**DWR51250** rett. F 53,90  
**DWL51250** lapp. rett. F 64,90

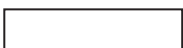

20x80 8  
DOWNTOWN GRAPHITE

**DWR4925B** rett. F 58,90



60x60 3  
DOWNTOWN GRAPHITE

**DWN01250** nat. F 46,90  
**DWR01250** rett. F 53,90  
**DWL01250** lapp. rett. F 64,90

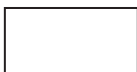

30x60 6  
DOWNTOWN GRAPHITE

**DWR03250** rett. F 49,90  
**DWL03250** lapp. rett. F 59,90



30x30 12  
DOWNTOWN GRAPHITE

**DWR09250** rett. F 53,90



30x30 6  
MOSAICO QUADRETTI GRAPHITE

**DWR09251** rett. F 101,90

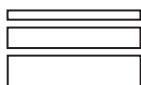

	Pcs/Box
5x60  6	
10x60  6	
15x60  6	

30x60 6  
DOWNTOWN GRAPHITE MIX SIZES  
**DWR00250** rett. F 74,90



30x60 2  
DEC. ONE WAY ARROW GRAPHITE

**DWR03251** rett. PZ 44,90

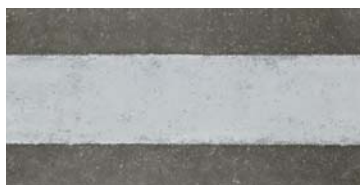

30x60 2  
DEC. ONE WAY LINE GRAPHITE

**DWR03252** rett. PZ 44,90



# Downtown

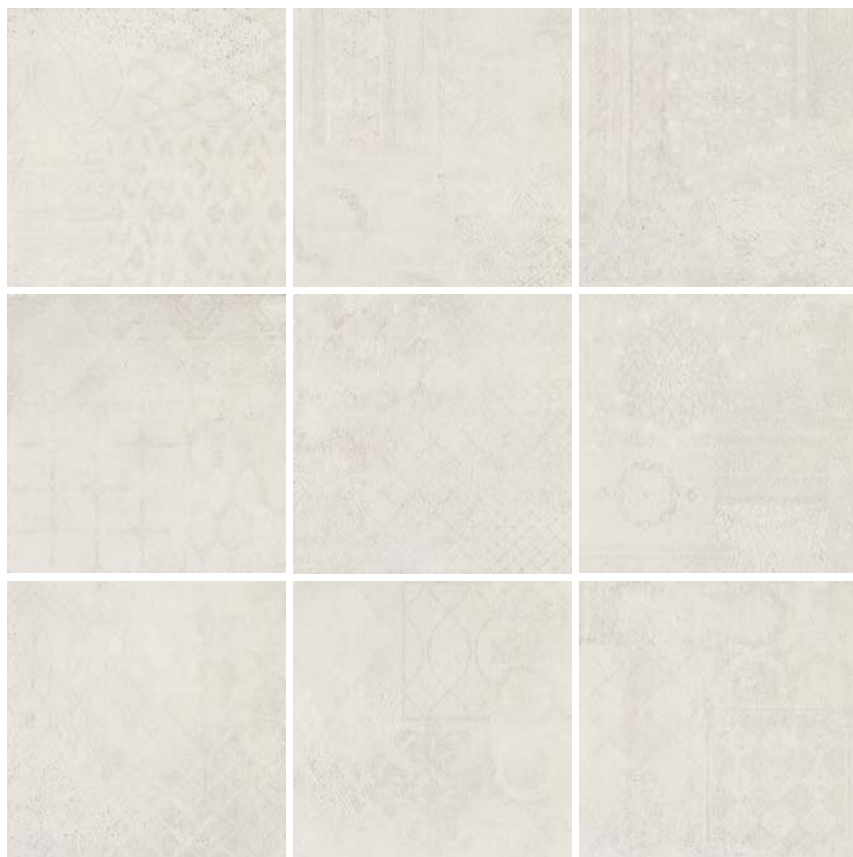



60x60  3  
DOWNTOWN IVORY RANDOM  
**DWR01060** rett. F 64,90





30x60  6  
DOWNTOWN IVORY RANDOM  
**DWR03060** rett. F 59,90



5x60  4  
LIST. DOWNTOWN IVORY RANDOM  
**DWR01061** rett. PZ 5,90

  
1,5x60  4  
MATITA METAL (alluminio - aluminium)  
**DWR01001** PZ 15,90

  
1,5x80  3  
MATITA METAL (alluminio - aluminium)  
**DKR51051** PZ 19,90

  
2x80  3  
LISTELLO FOGLIA ARGENTO (Vetro - Glass)  
**FSR51210** PZ 39,90

  
2x80  3 (Vetro - Glass)  
LISTELLO FOGLIA ORO  
**FSR51160** PZ 39,90

  
1,5x30  4  
FASCIA VETRO PLATINO  
**R1R03207** PZ 22,90

  
1,5x30  4  
FASCIA VETRO ORO  
**R1R03106** PZ 22,90

  
1,5x30  4  
FASCIA VETRO BRONZO  
**R1R03157** PZ 22,90

(Vetro e metalli preziosi - Glass and precious metals)

  
5x40  4  
\* LISTELLO WOOD  
**DKR51055** rett. PZ 19,90

\* Antico legno alpino recuperato da costruzioni dismesse e trattato per l'utilizzo in parete e a pavimento.

Ogni pezzo è unico e irripetibile.

Antique alpin wood, recovered from discontinued buildings and treated for floor and wall use. Every single piece turns out to be different and unique.





60x60  3  
 DOWNTOWN ECRU RANDOM  
**DWR01110** rett. F 64,90



30x60  6  
 DOWNTOWN ECRU RANDOM  
**DWR03110** rett. F 59,90



5x60  4  
 LIST. DOWNTOWN ECRU RANDOM  
**DWR01111** rett. PZ 5,90

# Downtown

floor. Ash Walk rett. 30x60



# Downtown

## PEZZI SPECIALI / SPECIAL TRIMS

	IVORY	ECRU	EARTH	ASH	GRAPHITE
 BATTISCOPA rett. 5,5x80 PZ 8,90  8	<b>DWR52054</b>	-	-	<b>DWR52204</b>	<b>DWR52254</b>
 BATTISCOPA rett. 5,5x60 PZ 7,90  10	<b>DWR01054</b>	<b>DWR01104</b>	<b>DWR01154</b>	<b>DWR01204</b>	<b>DWR01254</b>
 ELEMENTO L walk MONOL. 16,5x60x5 PZ 32,90  4	<b>DWN03501 WALK</b>	-	<b>DWN03551 WALK</b>	<b>DWN03601 WALK</b>	-
 GRADONE TOP rett. 33x60x4,5x2 PZ 79,90  2	<b>DWR01053</b>	<b>DWR01103</b>	<b>DWR01153</b>	<b>DWR01203</b>	<b>DWR01253</b>
 ANGOLARE TOP SX 33x60x4,5x2 PZ 108,90  1	<b>DWR01056</b>	<b>DWR01106</b>	<b>DWR01156</b>	<b>DWR01206</b>	<b>DWR01256</b>
	 ANGOLARE TOP DX 33x60x4,5x2 PZ 108,90  1	<b>DWR01055</b>	<b>DWR01105</b>	<b>DWR01155</b>	<b>DWR01205</b>

## IMBALLI/PACKAGING



F.to nominale Nominal size	F.to reale (mm) Real size (mm)	Spessore Thickness	Pz/Scatola Pcs/Box	Mq/Scatola Sqm/Box	Kg/Scatola Kg/Box	Scatole/Imballo Box/Packing	Mq totali Sqm total	Kg totali Kg total
* 80x80 / 32"x 32" rett.	800x800	11 mm	2	1,28	32,50	40	51,20	1320
* 40x80 / 16"x 32" rett.	400x800	9 mm	3	0,96	19,50	30	28,80	605
* 20x80 / 8"x 32" rett.	199x800	9 mm	8	1,28	24,00	42	53,76	1028
60x60 / 24"x24" nat./rett.	596x596	9 mm	3	1,08	21,20	40	43,20	868
30x60 / 12"x 24" rett.	297x596	9 mm	6	1,08	21,20	40	43,20	868
30x60 / 12"x 24" nat.	-	9 mm	6	1,08	20,50	40	43,20	840
30x30 / 12"x 12" rett.	297x297	9 mm	12	1,08	21,20	48	51,84	1038

L'unità minima di vendita per tutti gli articoli (fondi, decori e pezzi speciali) è la scatola completa. / The minimum sales quantity for all items (plain tiles, decorations and special trims) is one full box.

I dati relativi agli imballi sono aggiornati al momento della stampa del catalogo e pertanto possono subire variazioni nel corso del tempo. /

Data referring to packaging have been update at time of printing; the actual data may be slightly different.

Pezzi speciali e decori per effetto delle lavorazioni, possono presentare variazioni di tonalità. / Due to working process special trims and decors, may show variation in tonality.

 <b>HARDKOLL</b> LAYERS INNOVATIONS	SIGILLANTI COORDINATI PER FUGHE / COORDINATED GROUT SEALANTS			COLLANTI / ADHESIVES	
	DOWNTOWN	COLORE SIGILLANTE SEALANT COLOUR	CODICE SIGILLANTE SEALANT CODE		
	Downtown Ash		SI123B kromos manhattan	*Vedi tabella imballi / *See at packaging list	
	Downtown Ecrú		SI153B kromos tortora	Bauflex Bianco AD200M	Baulite S2 Bianco AD340M
	Downtown Earth		SI121B kromos cemento	Bauflex Grigio AD210M	Baulite S2 Grigio AD341M
	Downtown Ivory		SI120B kromos grigio luce		
	Downtown Graphite		SI122B kromos antracite		

Per una migliore resa estetica e tecnica ABK consiglia l'utilizzo di sigillanti e collanti HARDKOLL come da tabella. Per listino, scheda tecnica e approfondimenti vedi pag. 370  
ABK suggests Hardkoll sealants and adhesives for a better aesthetics and technical efficiency, as follow. Read more at page 370 for prices and technical data sheets.

# Downtown colours

---

## GRES PORCELLANATO A MASSA COLORATA

FULL BODY COLORED PORCELAIN STONEWARE

## SUPERFICI SURFACES

naturale - natural

antique - honed

bocciardato R11 - structured R11

## FORMATI SIZES



60x60  
24"x 24"



30x60  
12"x 24"



9 mm

---

Classificazione secondo norme UNI EN 14411 (ISO 13006) Allegato G Gruppo B1a  
Classification in accordance with UNI EN 14411 (ISO 13006) Annex G-Group B1a

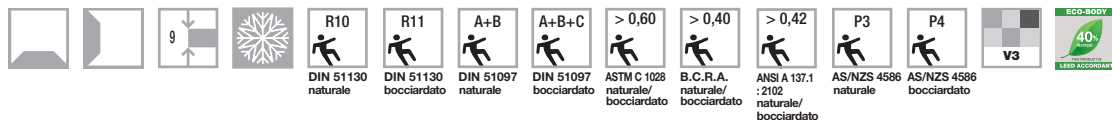





**GREY**



**WHITE**



**COPPER**



**DARK**



# Downtown colours

floor. grey antique rett. 60x60

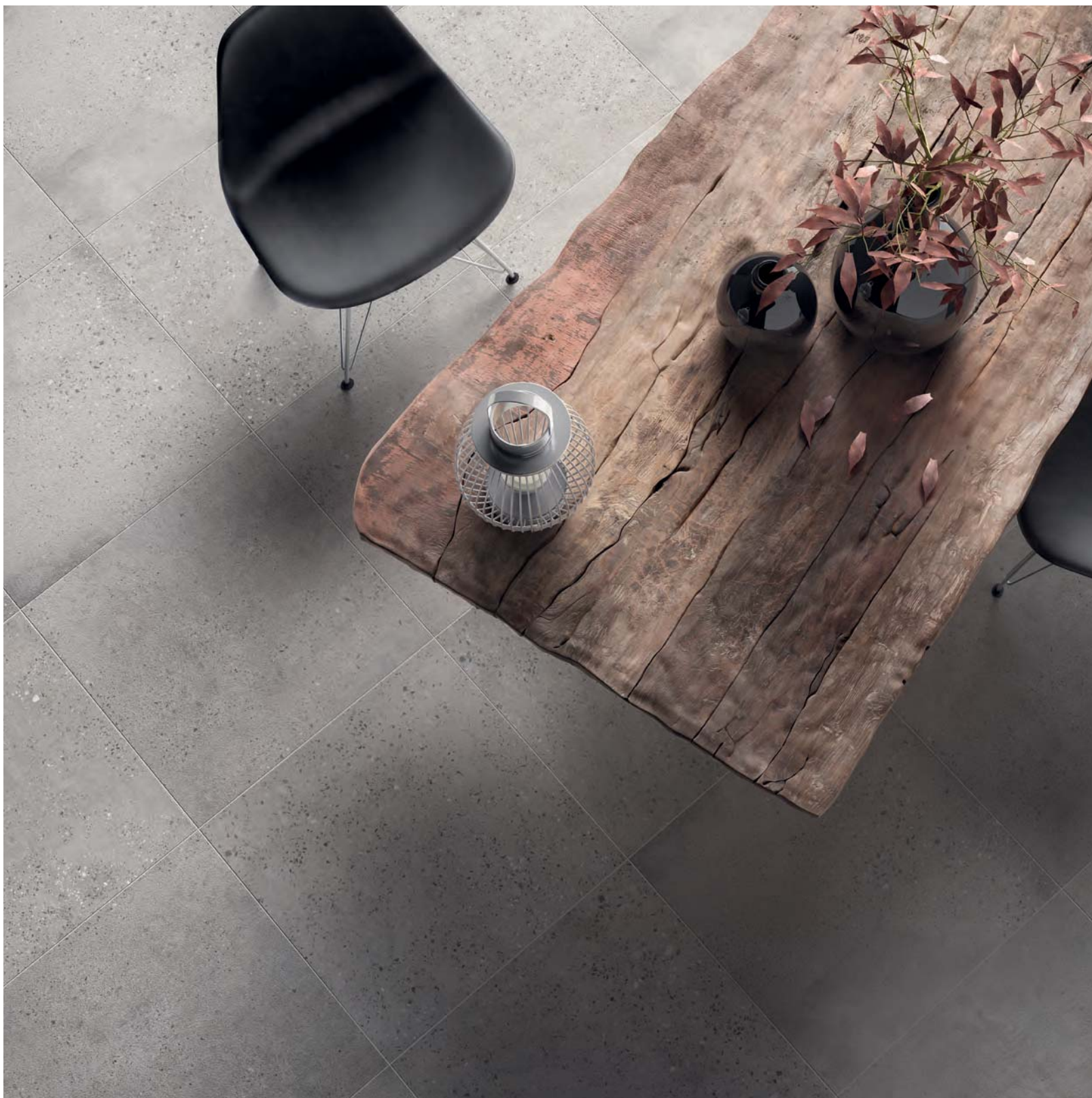



# Downtown colours

WHITE



60x60  3  
DOWNTOWN COLOURS WHITE  
**DWRO1300** rett. F 53,90

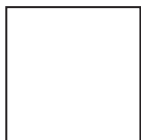

60x60  3  
DOWNTOWN COLOURS WHITE  
**DWL01300** antique rett. F 64,90



30x60  6  
DOWNTOWN COLOURS WHITE  
**DWR03300** rett. F 49,90

**OUTDOOR** R11

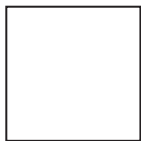

60x60  3  
DOWNTOWN COLOURS WHITE  
**DWR01650** bocc. rett. F 53,90



5x30  4  
\*FASCIA ESSENZE MIX  
**I9R03053** PZ 21,90  
(Legno - Wood)

\* Art. realizzati con materiali naturali:  
vedi indicazioni per posa e pulizia a  
pag. 393 dell' area tecnica.  
Items produced with natural materials:  
check the technical area at page 393.



# Downtown colours

GREY



60x60  3  
DOWNTOWN COLOURS GREY  
**DWR01350** rett. F 53,90



60x60  3  
DOWNTOWN COLOURS GREY  
**DWL01350** antique rett. F 64,90



30x60  6  
DOWNTOWN COLOURS GREY  
**DWR03350** rett. F 49,90

**OUTDOOR** R11

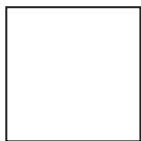

60x60  3  
DOWNTOWN COLOURS GREY  
**DWR01700** bocc. rett. F 53,90



5x30  4  
\*FASCIA ESSENZE MIX  
**I9R03053** PZ 21,90  
(Legno - Wood)

\* Art. realizzati con materiali naturali:  
vedi indicazioni per posa e pulizia a  
pag. 393 dell' area tecnica.  
Items produced with natural materials:  
check the technical area at page 393.



# Downtown colours

DARK

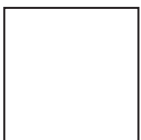

60x60  3  
DOWNTOWN COLOURS DARK  
**DWRO1450** rett. F 53,90

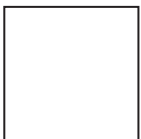

60x60  3  
DOWNTOWN COLOURS DARK  
**DWL01450** antique rett. F 64,90



30x60  6  
DOWNTOWN COLOURS DARK  
**DWR03450** rett. F 49,90

**OUTDOOR** R11

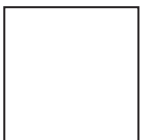

60x60  3  
DOWNTOWN COLOURS DARK  
**DWR01800** bocc. rett. F 53,90



5x30  4  
\*FASCIA ESSENZE MIX  
**I9R03053** PZ 21,90  
(Legno - Wood)

\* Art. realizzati con materiali naturali:  
vedi indicazioni per posa e pulizia a  
pag. 393 dell' area tecnica.  
Items produced with natural materials:  
check the technical area at page 393.



# Downtown colours

COPPER

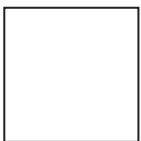

60x60  3  
DOWNTOWN COLOURS COPPER  
**DWR01400** rett. F 53,90

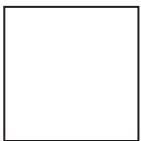

60x60  3  
DOWNTOWN COLOURS COPPER  
**DWL01400** antique rett. F 64,90



30x60  6  
DOWNTOWN COLOURS COPPER  
**DWR03400** rett. F 49,90

**OUTDOOR** R11

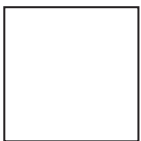

60x60  3  
DOWNTOWN COLOURS COPPER  
**DWR01750** bocc. rett. F 53,90



5x30  4  
\* FASCIA ESSENZE MIX  
**I9R03053** PZ 21,90  
(Legno - Wood)

\* Art. realizzati con materiali naturali:  
vedi indicazioni per posa e pulizia a  
pag. 393 dell' area tecnica.  
Items produced with natural materials:  
check the technical area at page 393.



floor. copper rett. 60x60 - 30x60

PEZZI SPECIALI / SPECIAL TRIMS					
		GREY	WHITE	COPPER	DARK
	BATTISCOPA rett. 5,5x60 PZ 7,90  10	<b>DWR01351</b>	<b>DWR01301</b>	<b>DWR01401</b>	<b>DWR01451</b>

#### IMBALLI/PACKAGING







F.to nominale Nominal size	F.to reale (mm) Real size (mm)	Spessore Thickness	Pz/Scatola Pcs/Box	Mq/Scatola Sqm/Box	Kg/Scatola Kg/Box	Scatole/Imballo Box/Packing	Mq totali Sqm total	Kg totali Kg total
60x60 / 24"x24" rett.	596x596	9 mm	3	1,08	21,20	40	43,20	868
30x60 / 12"x24" rett.	297x596	9 mm	6	1,08	21,20	40	43,20	840

L'unità minima di vendita per tutti gli articoli (fondi, decori e pezzi speciali) è la scatola completa. / The minimum sales quantity for all items (plain tiles, decorations and special trims) is one full box.

I dati relativi agli imballi sono aggiornati al momento della stampa del catalogo e pertanto possono subire variazioni nel corso del tempo. /

Data referring to packaging have been update at time of printing; the actual data may be slightly different.

Pezzi speciali e decori per effetto delle lavorazioni, possono presentare variazioni di tonalità. / Due to working process special trims and decors, may show variation in tonality.

	SIGILLANTI COORDINATI PER FUGHE / COORDINATED GROUT SEALANTS			COLLANTI / ADHESIVES	
	DOWNTOWN COLOURS	COLORE SIGILLANTE SEALANT COLOUR	CODICE SIGILLANTE SEALANT CODE		
	Downtown Colours Copper - Grey		SI121B kromos cemento	*Vedi tabella imballi / *See at packaging list	
	Downtown Colours White		SI120B kromos grigio luce		
Downtown Colours Dark		SI122B kromos antracite	Bauflex Bianco AD200M	Baurapid Grigio AD240M	
			Bauflex Grigio AD210M		

Per una migliore resa estetica e tecnica ABK consiglia l'utilizzo di sigillanti e collanti HARDKOLL come da tabella. Per listino, scheda tecnica e approfondimenti vedi pag. 370  
ABK suggests Hardkoll sealants and adhesives for a better aesthetics and technical efficiency, as follow. Read more at page 370 for prices and technical data sheets.

# Docks

## GRES PORCELLANATO A MASSA COLORATA

FULL BODY COLORED PORCELAIN STONEWARE

### SUPERFICI SURFACES

naturale - natural  
 patinato - honed  
 walk R11 - structured R11  
 form - form

### FORMATI SIZES



80x80  
32"x 32"



40x80  
16"x 32"



20x80  
8"x 32"



60x60  
24"x 24"



30x60  
12"x 24"



15x60  
6"x 24"



11 mm



9 mm

Classificazione secondo norme UNI EN 14411 (ISO 13006) Allegato G Gruppo Bla  
 Classification in accordance with UNI EN 14411 (ISO 13006) Annex G-Group Bla

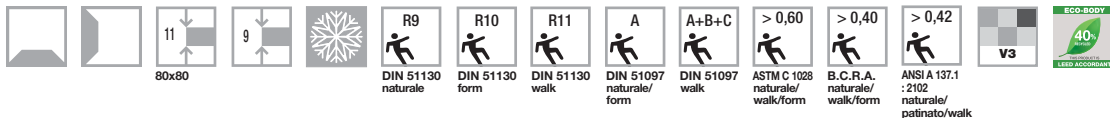



**BLACK**

**GREY**

**SILVER**

**WHITE**

**BONE**

**WARM**

# Docks

wall. Black 30x60 rett. - Mix sizes 30x60 rett. floor. Black 60x60 rett.





Wall. Silver Form rett. 30x60 - Dec. Combi 4 beige/rosso rett. - Dec. Combi 4 grigio/nero rett. - Dec. Combi 4 bianco/nero rett. - Dec. Combi 4 grigio/rosso rett. 30x30 floor. Silver rett. 60x60



# Docks

BLACK

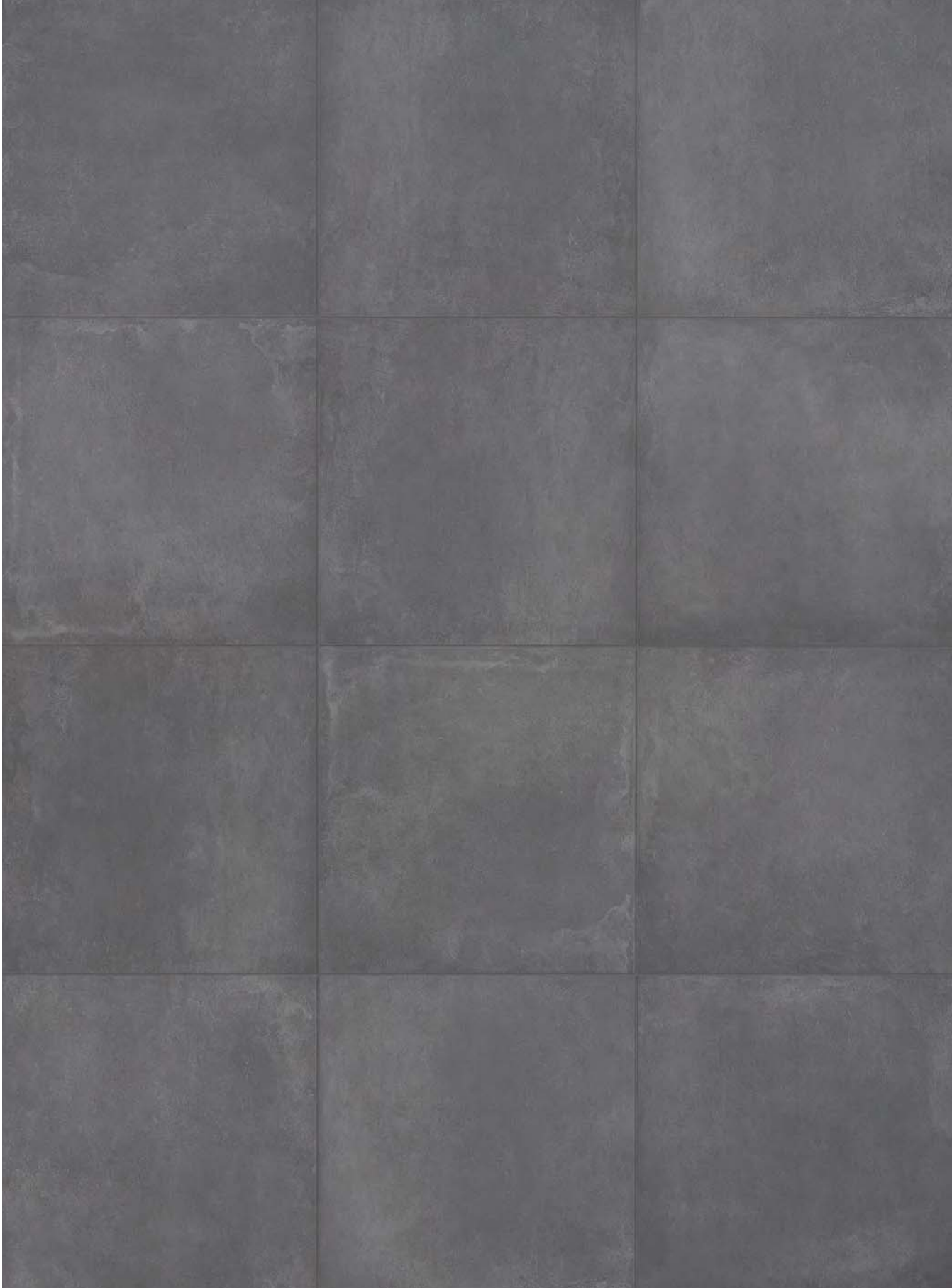

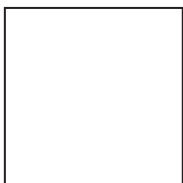

80x80  2  
DOCKS BLACK  
**DKR52200** rett. F 68,90  
**DKL52200** patinato rett. F 81,90

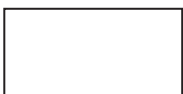

40x80  3  
DOCKS BLACK  
**DKR5120C** rett. F 53,90  
**DKL5120C** patinato rett. F 64,90



60x60  3  
DOCKS BLACK  
**DKN01200** nat. F 46,90  
**DKR01200** rett. F 53,90  
**DKL01200** patinato rett. F 64,90









30x60  6  
DOCKS BLACK  
**DKN03200** nat. F 38,90  
**DKR03200** rett. F 49,90  
**DKL03200** patinato rett. F 59,90



15x60  12  
DOCKS BLACK  
**DKR04200** rett. F 57,90

Pcs/Box:

	5x60  6
	10x60  6
	15x60  6

30x60  6  
DOCKS BLACK MIX SIZES  
**DKR00200** rett. F 74,90



30x30  6  
MOSAICO QUADRETTI BLACK  
**DKR09201** F 101,90



30x40  4  
MOSAICO BRICK GREY/BLACK  
**DKR51152** PZ 21,90  
(Miscelazione colori casuale - Random mixing colours)



5x80  4  
LIST. SOLERAS ANTRACITE  
**S1R49155** rett. PZ 6,90

# Docks

GREY





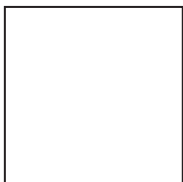

80x80 2  
DOCKS GREY  
**DKR52150** rett. F 68,90  
**DKL52150** patinato rett. F 81,90

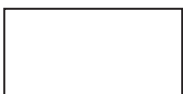

40x80 3  
DOCKS GREY  
**DKR5115C** rett. F 53,90  
**DKL5115C** patinato rett. F 64,90

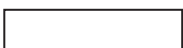

20x80 8  
DOCKS GREY  
**DKR4915B** rett. F 58,90  
**DKL4915B** patinato rett. F 67,90



60x60 3  
DOCKS GREY  
**DKN01150** nat. F 46,90  
**DKR01150** rett. F 53,90  
**DKL01150** patinato rett. F 64,90

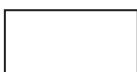

30x60 6  
DOCKS GREY  
**DKN03150** nat. F 38,90  
**DKR03150** rett. F 49,90  
**DKL03150** patinato rett. F 59,90

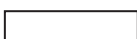

15x60 12  
DOCKS GREY  
**DKR04150** rett. F 57,90



30x30 6  
MOSAICO QUADRETTI GREY  
**DKR09151** F 101,90

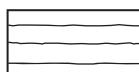

30x60 6  
DOCKS FORM GREY  
**DKR03600** rett. F 49,90

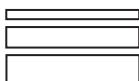

Pcs/Box:  
5x60 6  
10x60 6  
15x60 6  
30x60 6  
DOCKS GREY MIX SIZES  
**DKR00150** rett. F 74,90



30x40 4  
MOSAICO BRICK GREY/BLACK  
**DKR51152** PZ 21,90  
(Miscelazione colori casuale - Random mixing colours)



5x80 4  
LIST. SOLERAS ANTRACITE  
**STR49155** rett. PZ 6,90

OUTDOOR 9 mm

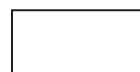

30x60 6  
DOCKS GREY  
**DKN03750** walk nat. F 38,90

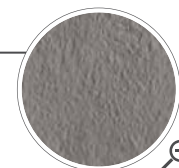

# Docks

SILVER



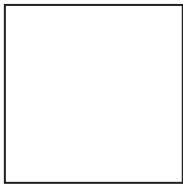

80x80 2  
DOCKS SILVER  
**DKR52100** rett. F 68,90  
**DKL52100** patinato rett. F 81,90



40x80 3  
DOCKS SILVER  
**DKR5110C** rett. F 53,90  
**DKL5110C** patinato rett. F 64,90



20x80 8  
DOCKS SILVER  
**DKR4910B** rett. F 58,90  
**DKL4910B** patinato rett. F 67,90

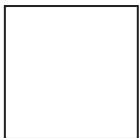

60x60 3  
DOCKS SILVER  
**DKN01100** nat. F 46,90  
**DKR01100** rett. F 53,90  
**DKL01100** patinato rett. F 64,90



30x60 6  
DOCKS SILVER  
**DKN03100** nat. F 38,90  
**DKR03100** rett. F 49,90  
**DKL03100** patinato rett. F 59,90



15x60 12  
DOCKS SILVER  
**DKR04100** rett. F 57,90



30x30 6  
MOSAICO QUADRETTI SILVER  
**DKR09101** F 101,90



30x60 6  
DOCKS FORM SILVER  
**DKR03550** rett. F 49,90

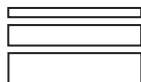

Pcs/Box:  
5x60 6  
10x60 6  
15x60 6

30x60 6  
DOCKS SILVER MIX SIZES  
**DKR00100** rett. F 74,90



30x40 4  
MOSAICO BRICK WHITE/SILVER  
**DKR51052** PZ 21,90  
(Miscelazione colori casuale - Random mixing colours)



5x80 4  
LIST. SOLERAS ANTRACITE  
**STR49155** rett. PZ 6,90



30x60 4  
DEC. MURALES SILVER MIX 4  
**DKR03113** rett. PZ 43,90



2x60 4  
MAT. MURALES BRONZE  
**DKR03064** rett. PZ 13,90

**OUTDOOR** **R11** 9 mm

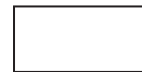

30x60 6  
DOCKS SILVER  
**DKN03700** walk nat. F 38,90

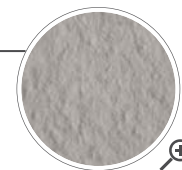

# Docks

WHITE







40x80  3  
DOCKS WHITE

**DKR5105C** rett. F 53,90  
**DKL5105C** patinato rett. F 64,90

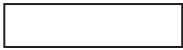

20x80  8  
DOCKS WHITE

**DKR4905B** rett. F 58,90  
**DKL4905B** patinato rett. F 67,90

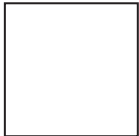

60x60  3  
DOCKS WHITE

**DKR01050** rett. F 53,90  
**DKL01050** patinato rett. F 64,90



30x60  6  
DOCKS WHITE

**DKR03050** rett. F 49,90  
**DKL03050** patinato rett. F 59,90



15x60  12  
DOCKS WHITE

**DKR04050** rett. F 57,90







30x30  6  
MOSAICO QUADRETTI WHITE  
**DKR09051** F 101,90

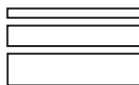

30x60  6  
DOCKS FORM WHITE  
**DKR03500** rett. F 49,90



Pcs/Box:  
5x60  6  
10x60  6  
15x60  6  
30x60  6  
DOCKS WHITE MIX SIZES  
**DKR00050** rett. F 74,90

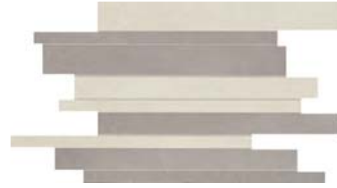

30x40  4  
MOSAICO BRICK WHITE/SILVER  
**DKR51052** PZ 21,90

(Miscelazione colori casuale - Random mixing colours)



5x80  4  
LIST. SOLERAS ANTRACITE  
**STR49155** rett. PZ 6,90



30x60  4  
DEC. MURALES WHITE MIX 4  
**DKR03063** rett. PZ 43,90



2x60  4  
MAT. MURALES BRONZE  
**DKR03064** rett. PZ 13,90

# Docks

BONE



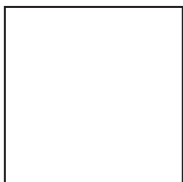

80x80 2  
DOCKS BONE  
**DKR52250** rett. F 68,90  
**DKL52250** patinato rett. F 81,90



40x80 3  
DOCKS BONE  
**DKR5125C** rett. F 53,90  
**DKL5125C** patinato rett. F 64,90



20x80 8  
DOCKS BONE  
**DKR4925B** rett. F 58,90  
**DKL4925B** patinato rett. F 67,90



60x60 3  
DOCKS BONE  
**DKN01250** nat. F 46,90  
**DKR01250** rett. F 53,90  
**DKL01250** patinato rett. F 64,90



30x60 6  
DOCKS BONE  
**DKN03250** nat. F 38,90  
**DKR03250** rett. F 49,90  
**DKL03250** patinato rett. F 59,90

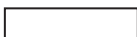

15x60 12  
DOCKS BONE  
**DKR04250** rett. F 57,90



30x30 6  
MOSAICO QUADRETTI BONE  
**DKR09251** F 101,90

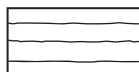

30x60 6  
DOCKS FORM BONE  
**DKR03650** rett. F 49,90



Pcs/Box:  
5x60 6  
10x60 6  
15x60 6  
30x60 6  
DOCKS BONE MIX SIZES  
**DKR00250** rett. F 74,90



30x40 4  
MOSAICO BRICK BONE/WARM  
**DKR51252** PZ 21,90  
(Miscelazione colori casuale - Random mixing colours)



5x80 4  
LIST. SOLERAS AVANA  
**STR49255** rett. PZ 6,90



30x60 4  
DEC. MURALES BONE MIX 4  
**DKR03263** rett. PZ 43,90



2x60 4  
MAT. MURALES BRONZE  
**DKR03064** rett. PZ 13,90

# Docks

WARM

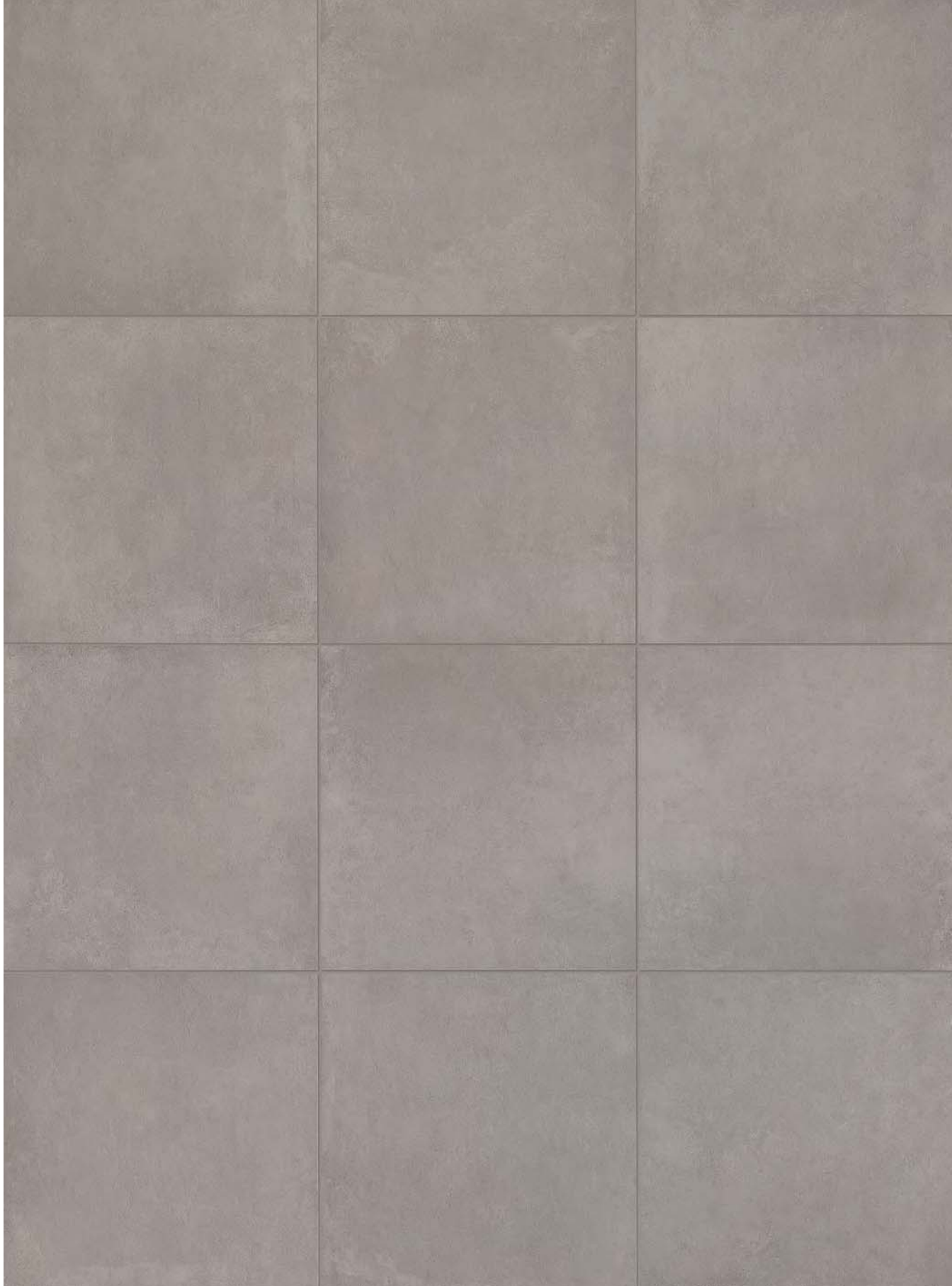





40x80 3  
DOCKS WARM  
**DKR5130C** rett. F 53,90  
**DKL5130C** patinato rett. F 64,90

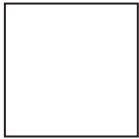

60x60 3  
DOCKS WARM  
**DKR01300** rett. F 53,90  
**DKL01300** patinato rett. F 64,90



30x60 6  
DOCKS WARM  
**DKR03300** rett. F 49,90  
**DKL03300** patinato rett. F 59,90



15x60 12  
DOCKS WARM  
**DKR04300** rett. F 57,90

Pcs/Box:  
 5x60 6  
 10x60 6  
 15x60 6

30x60 6  
DOCKS WARM MIX SIZES  
**DKR00300** rett. F 74,90



30x30 6  
MOSAICO QUADRETTI WARM  
**DKR09301** F 101,90



30x40 4  
MOSAICO BRICK BONE/WARM  
**DKR51252** PZ 21,90  
(Miscelazione colori casuale - Random mixing colours)

**OUTDOOR** **R11** 9 mm



30x60 6  
DOCKS WARM  
**DKN03800** walk nat. F 38,90



# Docks



20x80  3  
DEC. VINTAGE LIGHT MIX 3  
**DKR49053** rett. PZ 48,90



20x80  3  
DEC. VINTAGE DARK MIX 3  
**DKR49054** rett. PZ 48,90

## DOCKS VETRO E METALLI PREZIOSI

1,5x30  4  
FASCIA VETRO ORO  
**R1R03106** PZ 22,90

## DOCKS VETRO E METALLI PREZIOSI

1,5x30  4  
FASCIA VETRO PLATINO  
**R1R03207** PZ 22,90

## DOCKS VETRO E METALLI PREZIOSI

1,5x30  4  
FASCIA VETRO BRONZO  
**R1R03157** PZ 22,90

(Vetro e metalli preziosi - Glass and precious metals)

1,5x80  3  
MATITA METAL (alluminio - aluminium)  
**DKR51051** PZ 19,90



15x60  4  
DEC. VINTAGE MIX 4  
**DKR04051** rett. PZ 26,90



5x40  4  
\* LISTELLO WOOD  
**DKR51055** rett. PZ 19,90

Antico legno alpino recuperato da costruzioni dismesse e trattato per l'utilizzo in parete e a pavimento.

**Ogni pezzo è unico e irripetibile.**

Antique alpin wood, recovered from discontinued buildings and treated for floor and wall use. Every single piece turns out to be different and unique.



5x30  4  
\* FASCIA ESSENZE MIX  
**I9R03053** PZ 21,90  
(Legno - Wood)



15x60  2  
DEC. SPLASH BLUE MIX 2  
**DKL04051** rett. PZ 39,90

2x60  4  
MATITA SPLASH BLUE  
**DKL04052** rett. PZ 13,90

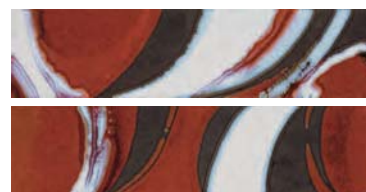

15x60  2  
DEC. SPLASH ARANCIO MIX 2  
**DKL04251** rett. PZ 39,90

2x60  4  
MATITA SPLASH ARANCIO  
**DKL04252** rett. PZ 13,90

10x60  4  
LIST. OPERA BLUE  
**DKR03062** rett. PZ 26,90

10x60  4  
LIST. OPERA RED  
**DKR03262** rett. PZ 26,90

# Docks

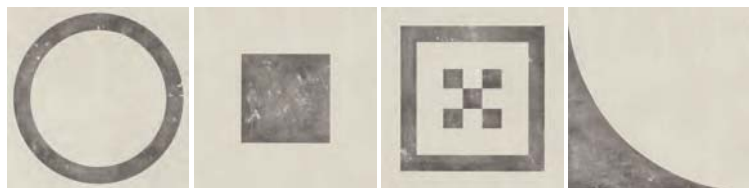

30x30  4  
DECORO COMBI 4 BIANCO/NERO  
DKR01062 rett. PZ 26,90



30x30  4  
DECORO COMBI 4 BEIGE/ROSSO  
DKR01262 rett. PZ 26,90



30x30  4  
DECORO COMBI 4 GRIGIO/NERO  
DKR01112 rett. PZ 26,90



30x30  4  
DECORO COMBI 4 GRIGIO/ROSSO  
DKR01113 rett. PZ 26,90

wall. Dec. Combi 4 beige/rosso rett. 30x30 floor. Bone pat. rett. 40x80 - 20x80













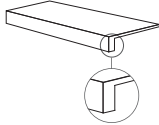

# Docks

wall. White rett. 20x80 - Dec. Vintage light mix 3 rett. - Dec. Vintage dark mix 3 rett. floor. White rett. 40x80





PEZZI SPECIALI / SPECIAL TRIMS		BLACK	GREY	SILVER	WHITE	BONE	WARM
	BATTISCOPIA nat. 5,5x60 PZ 7,90  10	<b>DKN01202</b>	<b>DKN01152</b>	<b>DKN01102</b>	-	<b>DKN01252</b>	-
	BATTISCOPIA rett. 5,5x60 PZ 7,90  10	<b>DKR01202</b>	<b>DKR01152</b>	<b>DKR01102</b>	<b>DKR01052</b>	<b>DKR01252</b>	<b>DKR01302</b>
	BATTISCOPIA rett. 5,5x80 PZ 8,90  8	<b>DKR52202</b>	<b>DKR52152</b>	<b>DKR52102</b>	-	<b>DKR52252</b>	-
	GRADONE TOP rett. 33x60x4,5x2 PZ 79,90  2	<b>DKR03206</b>	<b>DKR03156</b>	<b>DKR03106</b>	<b>DKR03056</b>	<b>DKR03256</b>	<b>DKR03306</b>
	ANGOLARE TOP SX 32x60x4,5x2 PZ 108,90  1	<b>DKR03207</b>	<b>DKR03157</b>	<b>DKR03107</b>	<b>DKR03057</b>	<b>DKR03257</b>	<b>DKR03307</b>
	ANGOLARE TOP DX 32x60x4,5x2 PZ 108,90  1	<b>DKR03208</b>	<b>DKR03158</b>	<b>DKR03108</b>	<b>DKR03058</b>	<b>DKR03258</b>	<b>DKR03308</b>
	ELEM. L WALK 16,5x60x5 PZ 32,90  4	-	<b>DKN03751 GREY WALK</b>	<b>DKN03701 SILVER WALK</b>	-	-	<b>DKN03801 WARM WALK</b>

## IMBALLI/PACKAGING

F.to nominale Nominal size	F.to reale (mm) Real size (mm)	Spessore Thickness	Pz/Scatola Pcs/Box	Mq/Scatola SqM/Box	Kg/Scatola Kg/Box	Scatole/Imballo Box/Packing	Mq totali SqM total	Kg totali Kg total
*80x80 / 32"x 32" rett.	800x800	11 mm	2	1,28	32,50	40	51,20	1320
*40x80 / 16"x 32" rett.	400x800	9 mm	3	0,96	19,50	30	28,80	605
*20x80 / 8"x 32" rett.	199x800	9 mm	8	1,28	24,00	42	53,76	1028
60x60 / 24"x24" nat./rett	596x596	9 mm	3	1,08	21,20	40	43,20	868
30x60 / 12"x 24" rett.	297x596	9 mm	6	1,08	21,20	40	43,20	868
30x60 / 12"x 24" mix sizes rett.	297x596	9 mm	6	1,08	21,20	40	43,20	868
30x60 / 12"x 24" nat.	-	9 mm	6	1,08	20,50	40	43,20	840
15x60 / 6"x 24" rett.	147,5x596	9 mm	12	1,08	21,20	40	43,20	868

L'unità minima di vendita per tutti gli articoli (fondi, decori e pezzi speciali) è la scatola completa. / The minimum sales quantity for all items (plain tiles, decorations and special trims) is one full box.  
I dati relativi agli imballi sono aggiornati al momento della stampa del catalogo e pertanto possono subire variazioni nel corso del tempo. / Data referring to packaging have been update at time of printing; the actual data may be slightly different.  
Pezzi speciali e decori per effetto delle lavorazioni, possono presentare variazioni di tonalità. / Due to working process special trims and decors, may show variation in tonality.

## SIGILLANTI COORDINATI PER FUGHE / COORDINATED GROUT SEALANTS

DOCKS	COLORE SIGILLANTE SEALANT COLOUR	CODICE SIGILLANTE SEALANT CODE
Docks Silver		SI150B kromos perla
Docks Grey		SI152B kromos ardesia
Docks Black		SI122B kromos antracite
Docks White		SI120B kromos grigio luce
Docks Bone		SI153B kromos tortora
Docks Warm		SI123B kromos manhattan

## COLLANTI / ADHESIVES

	
Bauflex Bianco AD200M	Baulite S2 Bianco AD340M
Bauflex Grigio AD210M	Baulite S2 Grigio AD341M

\*Vedi tabella imballi /  
\*See at packaging list

Per una migliore resa estetica e tecnica ABK consiglia l'utilizzo di sigillanti e collanti HARDKOLL come da tabella. Per listino, scheda tecnica e approfondimenti vedi pag. 370  
ABK suggests Hardkoll sealants and adhesives for a better aesthetics and technical efficiency, as follow. Read more at page 370 for prices and technical data sheets.

# Papier

---

## GRES PORCELLANATO A MASSA COLORATA

FULL BODY COLORED PORCELAIN STONEWARE

## SUPERFICI SURFACES

naturale - natural

## FORMATI SIZES



60x60  
24"x 24"



---

Classificazione secondo norme UNI EN 14411 (ISO 13006) Allegato G Gruppo Bla  
Classification in accordance with UNI EN 14411 (ISO 13006) Annex G-Group Bla



**GRIGIO**

**ANTRACITE**

**CORDA**

**NOCCIOLA**



# Papier

floor. Nocciola rett. 60x60





# Papier

ANTRACITE

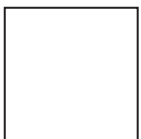

60x60  3  
PAPIER ANTRACITE

**PPR01300** rett. F 53,90



# Papier

GRIGIO

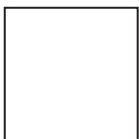

60x60  3  
PAPIER GRIGIO

PPR01250 rett.

F 53,90

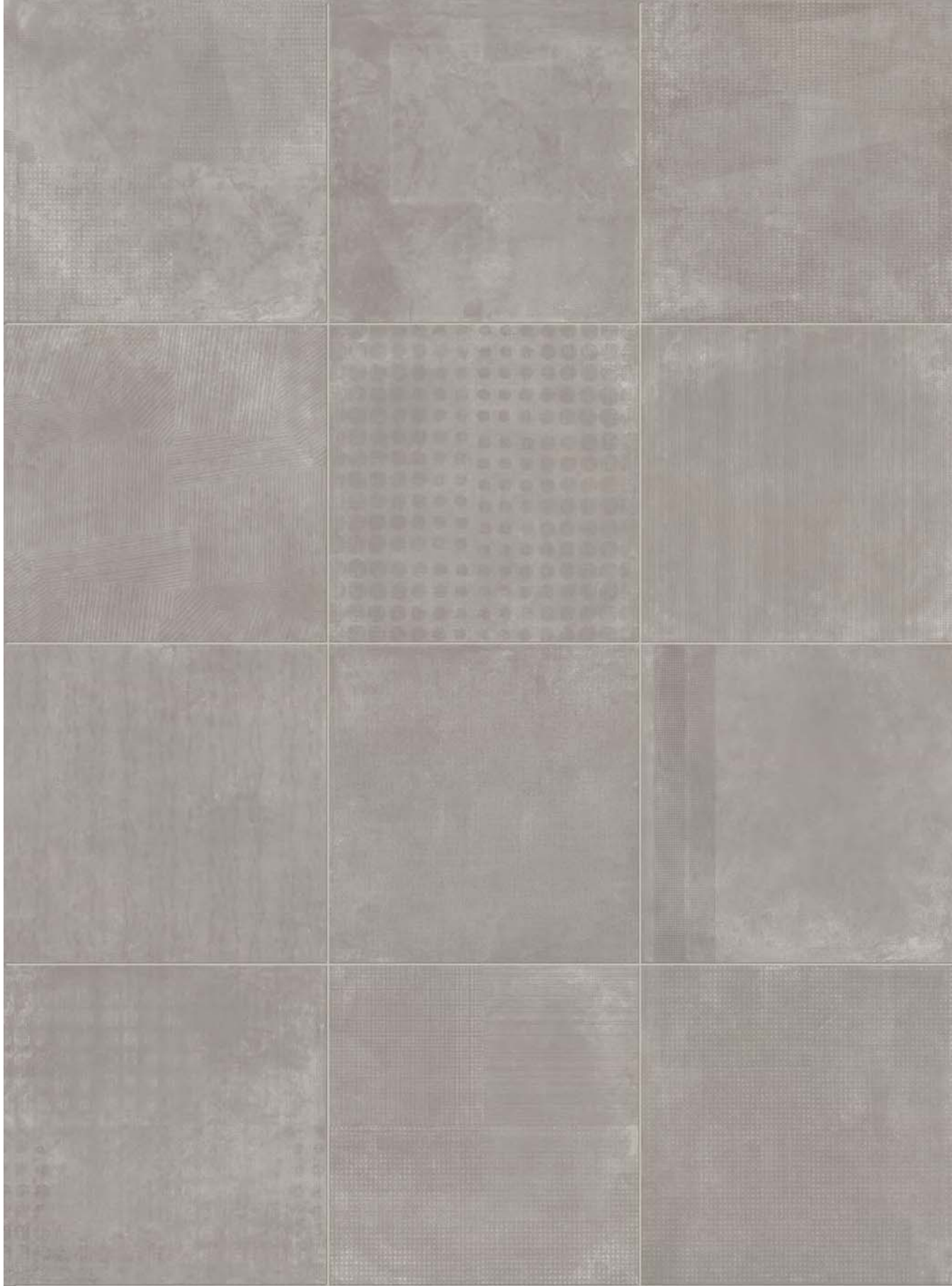

# Papier

CORDA

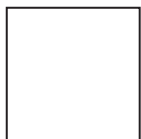

60x60  3  
PAPIER CORDA

**PPR01100** rett.

F 53,90

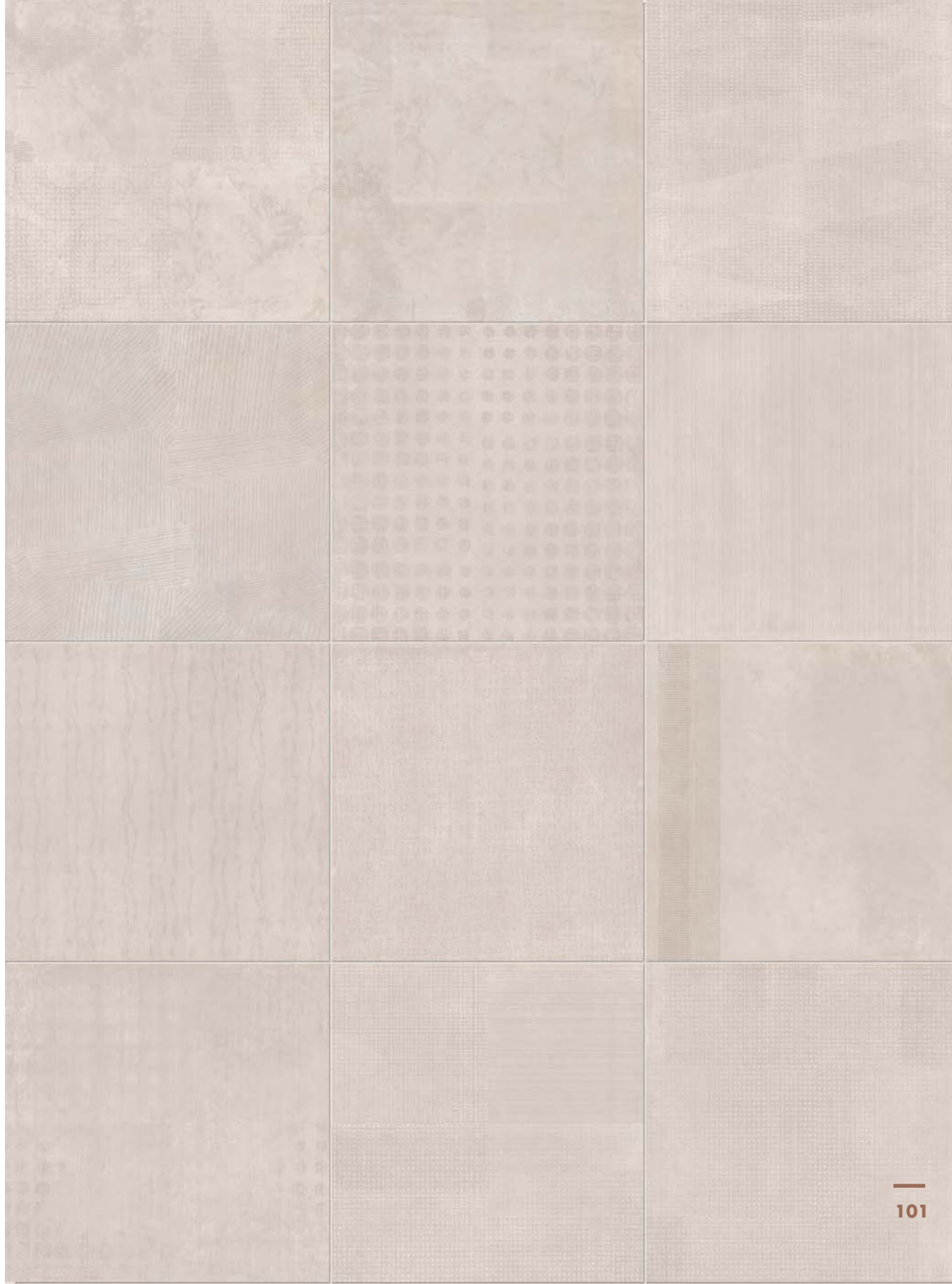



# Papier

NOCCIOLA

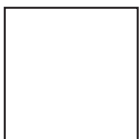

60x60  3  
PAPIER NOCCIOLA

PPR01150 rett.

F 53,90

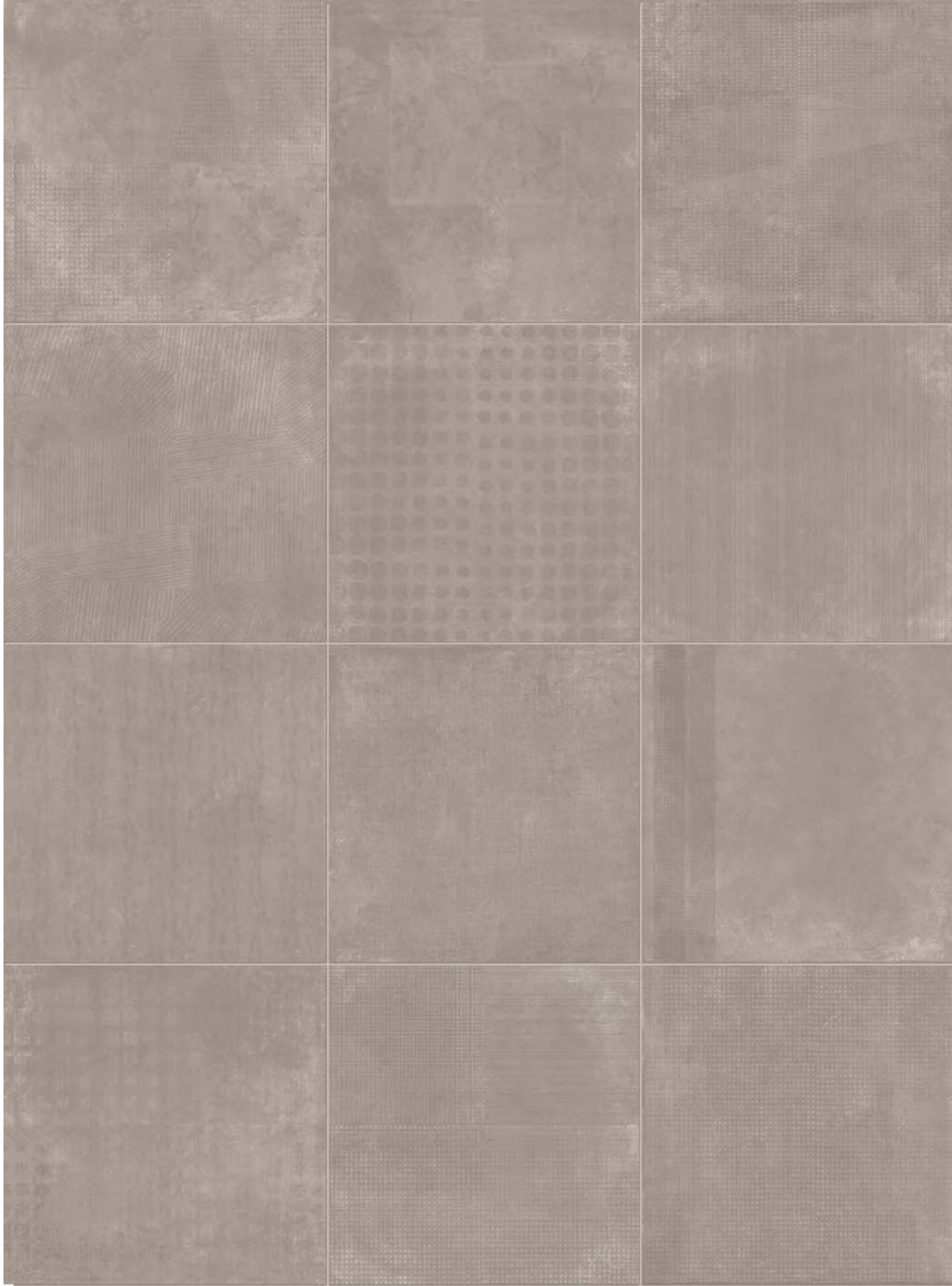



# Papier

## PEZZI SPECIALI / SPECIAL TRIMS



		PAPER ANTRACITE	PAPER GRIGIO	PAPER CORDA	PAPER NOCCIOLA
	BATTISCOPA rett. 6,5x60 PZ 7,90  10	<b>PPR01301</b>	<b>PPR01251</b>	<b>PPR01101</b>	<b>PPR01151</b>

## IMBALLI/PACKAGING

F.to nominale Nominal size	F.to reale (mm) Real size (mm)	Spessore Thickness	Pz/Scatola Pcs/Box	Mq/Scatola Sqm/Box	Kg/Scatola Kg/Box	Scatole/Imballo Box/Packing	Mq totali Sqm total	Kg totali Kg total
60x60 / 24"x24" rett.	596x596	9 mm	3	1,08	21,20	40	43,20	868

L'unità minima di vendita per tutti gli articoli (fondi, decori e pezzi speciali) è la scatola completa. / The minimum sales quantity for all items (plain tiles, decorations and special trims) is one full box.  
I dati relativi agli imballi sono aggiornati al momento della stampa del catalogo e pertanto possono subire variazioni nel corso del tempo. /  
Data referring to packaging have been update at time of printing; the actual data may be slightly different.

Pezzi speciali e decori per effetto delle lavorazioni, possono presentare variazioni di tonalità. / Due to working process special trims and decors, may show variation in tonality.

 LIVING INNOVATIONS	SIGILLANTI COORDINATI PER FUGHE / COORDINATED GROUT SEALANTS			COLLANTI / ADHESIVES	
	PAPIER	COLORE SIGILLANTE SEALANT COLOUR	CODICE SIGILLANTE SEALANT CODE		
	Papier Nocciola		SI123B kromos manhattan	Bauflex Bianco AD200M	Baurapid Grigio AD240M
	Papier Grigio		SI121B kromos cemento		
	Papier Corda		SI120B kromos grigio luce	Bauflex Grigio AD210M	
Papier Antracite		SI122B kromos antracite			

Per una migliore resa estetica e tecnica ABK consiglia l'utilizzo di sigillanti e collanti HARDKOLL come da tabella. Per listino, scheda tecnica e approfondimenti vedi pag. 370  
ABK suggests Hardkoll sealants and adhesives for a better aesthetics and technical efficiency, as follow. Read more at page 370 for prices and technical data sheets.

# Evolution

---

## GRES PORCELLANATO A MASSA COLORATA

FULL BODY COLORED PORCELAIN STONEWARE

## SUPERFICI SURFACES

satinato - satin  
 lappato - honed

## FORMATI SIZES



60x60  
24"x 24"



30x60  
12"x 24"

▼  
9 mm  
▲



CARBONE



TORTORA

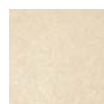

AVORIO

---

Classificazione secondo norme UNI EN 14411 (ISO 13006) Allegato G Gruppo B1a  
Classification in accordance with UNI EN 14411 (ISO 13006) Annex G-Group B1a



floor. Carbone rett. 60x60



# Evolution

## CARBONE



60x60  3

EVOLUTION CARBONE

**EEN3050C** satinato nat. F 46,90

**EES3050D** satinato rett. F 53,90

**EEL3050D** lappato rett. F 64,90



30x60  6

EVOLUTION CARBONE

**EES3550D** satinato rett. F 49,90

**EEL3550D** lappato rett. F 59,90



33,3x33,3  5

MOS. RETTANGOLI CARBONE

**EES1070** sat. rett. PZ 21,90



33,3x33,3  5

MOS. STICKS CARBONE

**EES1073** sat. rett. PZ 22,90



33,3x33,3  5

MOS. MET. RIP. CARBONE

**EES1072** sat. rett. PZ 15,90



33,3x33,3  5

MOS. METALLO CARBONE

**EES1071** sat. rett. PZ 32,90

(Metalli preziosi - Precious metals)



# Evolution

TORTORA



60x60 3  
EVOLUTION TORTORA

<b>EEN3000C</b>	satinato nat.	F 46,90
<b>EES3000D</b>	satinato rett.	F 53,90
<b>EEL3000D</b>	lappato rett.	F 64,90



30x60 6  
EVOLUTION TORTORA

<b>EES3500D</b>	satinato rett.	F 49,90
<b>EEL3500D</b>	lappato rett.	F 59,90



33,3x33,3 5  
MOS. RETTANGOLI TORTORA

<b>EES1020</b>	sat. rett.	PZ 21,90
----------------	------------	----------



33,3x33,3 5  
MOS. MET. RIP. TORTORA

<b>EES1022</b>	sat. rett.	PZ 15,90
----------------	------------	----------



11x33,3 12  
FORMELLA CHIC ANTRACITE

<b>EES1319</b>	rett.	PZ 30,90
----------------	-------	----------



4x33,3 12  
LIST. CHIC ANTRACITE

<b>EES1315</b>	rett.	PZ 17,90
----------------	-------	----------



\* 2,5x33,3 12  
CORD. CHIC ANTRACITE

<b>EES1316</b>	rett.	PZ 12,90
----------------	-------	----------



\* 3x33,3 12  
LIST. NET GRIGIO

<b>EES1467</b>	rett.	PZ 16,90
----------------	-------	----------



\* 1,5x33,3 24  
CORD. NET GRIGIO

<b>EES1468</b>	rett.	PZ 12,90
----------------	-------	----------



\*\* 3x33,3 6  
F. MOON TORTORA/CARBONE

<b>EEL1055</b>	lapp. rett.	PZ 24,90
----------------	-------------	----------



\*\* 3x33,3 6  
F. MOON TORTORA/FUMO

<b>EEL1005</b>	lapp. rett.	PZ 24,90
----------------	-------------	----------



33,3x33,3 5  
MOS. STICKS TORTORA

<b>EES1023</b>	sat. rett.	PZ 22,90
----------------	------------	----------

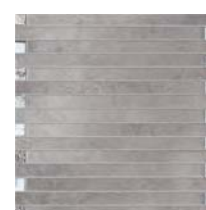

33,3x33,3 5  
MOS. METALLO TORTORA

<b>EES1021</b>	sat. rett.	PZ 32,90
----------------	------------	----------

(Metalli preziosi - Precious metals)



3x33,3 6  
FASCIA URBAN (alluminio - aluminium)

<b>EES1001</b>	rett.	PZ 15,90
----------------	-------	----------



1,5x33,3 12  
LIST. URBAN (alluminio - aluminium)

<b>EES1301</b>	rett.	PZ 13,90
----------------	-------	----------



5x5 12  
TOZZ. URBAN (alluminio - aluminium)

<b>EES1003</b>	rett.	PZ 6,90
----------------	-------	---------



1x33,3 12  
MATITA SPEED PLATINO (vetro - glass)

<b>EES1560</b>	rett.	PZ 21,90
----------------	-------	----------



1x33,3 12  
MATITA SPEED ROSSO (vetro - glass)

<b>EES1310</b>	rett.	PZ 21,90
----------------	-------	----------

\* Dec. soggetto a stonizzazione.  
Colour-shaded decorative tile.

\*\* Decoro realizzato in vetro, porcellanato, legno e alluminio  
Decorative piece in glass, porcelain stoneware, wood and aluminium

# Evolution

AVORIO

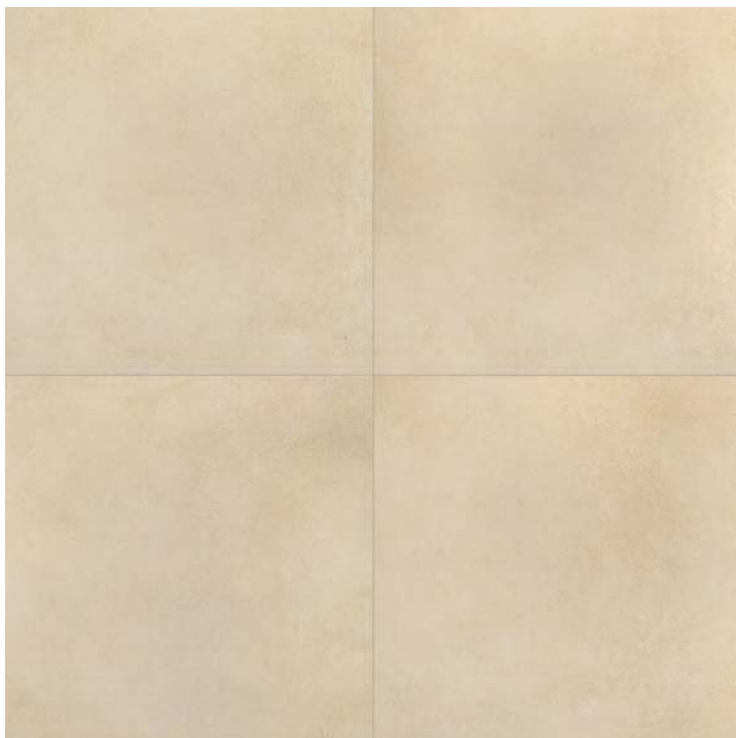

60x60  3  
EVOLUTION AVORIO

**EEN3150C** satinato nat. F 46,90  
**EES3150D** satinato rett. F 53,90  
**EEL3150D** lappato rett. F 64,90



30x60  6  
EVOLUTION AVORIO

**EES3650D** satinato rett. F 49,90  
**EEL3650D** lappato rett. F 59,90



33,3x33,3  5  
MOS. RETTANGOLI AVORIO  
**EES1170** sat. rett. PZ 21,90



33,3x33,3  5  
MOS. STICKS AVORIO  
**EES1173** sat. rett. PZ 22,90



33,3x33,3  5  
MOS. MET. RIP. AVORIO  
**EES1172** sat. rett. PZ 15,90



33,3x33,3  5  
MOS. METALLO AVORIO  
**EES1171** sat. rett. PZ 32,90  
(Metalli preziosi - Precious metals)



4x33,3  12  
LIST. CHIC BRONZO  
**EES1465** rett. PZ 17,90



3x33,3  6  
FASCIA URBAN (alluminio - aluminium)  
**EES1001** rett. PZ 15,90



2,5x33,3  12  
CORD. CHIC BRONZO  
**EES1466** rett. PZ 12,90



1,5x33,3  12  
LIST. URBAN (alluminio - aluminium)  
**EES1301** rett. PZ 13,90



\* 3x33,3  12  
LIST. NET PANNA  
**EES1317** rett. PZ 16,90



5x5  12  
TOZZ. URBAN (alluminio - aluminium)  
**EES1003** rett. PZ 6,90



\* 1,5x33,3  24  
CORD. NET PANNA  
**EES1318** rett. PZ 12,90



\*\* 3x33,3  6  
F. MOON AVORIO/OLIVA  
**EEL1155** lapp. rett. PZ 24,90







\*\* 3x33,3  6  
F. MOON BEIGE/CAFFÉ  
**EEL1755** lapp. rett. PZ 24,90

\* Dec. soggetto a stonizzazione.  
Colour-shaded decorative tile.

\*\* Decoro realizzato in vetro, porcellanato, legno e alluminio  
Decorative piece in glass, porcelain stoneware, wood  
and aluminium

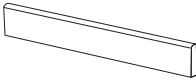
# Evolution

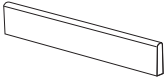



## PEZZI SPECIALI / SPECIAL TRIMS

		CARBONE	TORTORA	AVORIO
	BATTISCOPA sat. nat. 10x60 PZ 7,90  10	<b>EEN3051S</b>	<b>EEN3001S</b>	<b>EEN3151S</b>
	BATTISCOPA sat. rett. 10x60 PZ 7,90  10	<b>EES3052</b>	<b>EES3002</b>	<b>EES3152</b>
	BATTISCOPA sat. nat. 10x50 PZ 5,90  12	<b>EEN108S</b>	<b>EEN058S</b>	<b>EEN208S</b>
	BATTISCOPA sat. rett. 10x50 PZ 5,90  12	<b>EES108S</b>	<b>EES058S</b>	<b>EES208S</b>

## IMBALLI/PACKAGING

F.to nominale Nominal size	F.to reale (mm) Real size (mm)	Spessore Thickness	Pz/Scatola Pcs/Box	Mq/Scatola Sqm/Box	Kg/Scatola Kg/Box	Scatole/Imballo Box/Packing	Mq totali Sqm total	Kg totali Kg total
60x60 / 24"x24" rett.	596x596	9 mm	3	1,08	21,20	40	43,20	868
30x60 / 12"x24" rett.	297x596	9 mm	6	1,08	21,20	40	43,20	868

L'unità minima di vendita per tutti gli articoli (fondi, decori e pezzi speciali) è la scatola completa. / The minimum sales quantity for all items (plain tiles, decorations and special trims) is one full box.  
I dati relativi agli imballi sono aggiornati al momento della stampa del catalogo e pertanto possono subire variazioni nel corso del tempo. /  
Data referring to packaging have been update at time of printing; the actual data may be slightly different.  
Pezzi speciali e decori per effetto delle lavorazioni, possono presentare variazioni di tonalità. / Due to working process special trims and decors, may show variation in tonality.

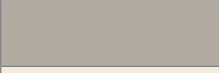
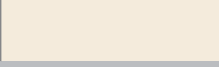
	SIGILLANTI COORDINATI PER FUGHE / COORDINATED GROUT SEALANTS			COLLANTI / ADHESIVES	
	EVOLUTION	COLORE SIGILLANTE SEALANT COLOUR	CODICE SIGILLANTE SEALANT CODE		
	Evolution Carbone		SI140B kromos nero	Bauflex Bianco AD200M	Baurapid Grigio AD240M
	Evolution Tortora		SI150B kromos perla	Bauflex Grigio AD210M	
	Evolution Avorio		SI126B kromos avorio		

Per una migliore resa estetica e tecnica ABK consiglia l'utilizzo di sigillanti e collanti HARDKOLL come da tabella. Per listino, scheda tecnica e approfondimenti vedi pag. 370  
ABK suggests Hardkoll sealants and adhesives for a better aesthetics and technical efficiency, as follow. Read more at page 370 for prices and technical data sheets.

# Level

---

## GRES PORCELLANATO A MASSA COLORATA

FULL BODY COLORED PORCELAIN STONEWARE

## SUPERFICI SURFACES

naturale - natural

## FORMATI SIZES



60x60  
24"x 24"



30x60  
12"x 24"

9 mm

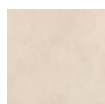

IVORY

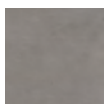

GREY



SILVER



BLACK

---

Classificazione secondo norme UNI EN 14411 (ISO 13006) Allegato G Gruppo Bla  
Classification in accordance with UNI EN 14411 (ISO 13006) Annex G-Group Bla





floor. Black 60x60

*soup & salad*

SALAD SHRIMP SALAD - CHICKEN SPINACH SALAD - CAESAR S

ASIAN SALAD - ASIAN SALAD - CHOPPED SALAD

CHEF SALAD - COMBO SALAD - TOSSED SALAD

SOUP SHOPPE SALAD - MUSHROOM and BRIE

NEW ENGLAND CLAM



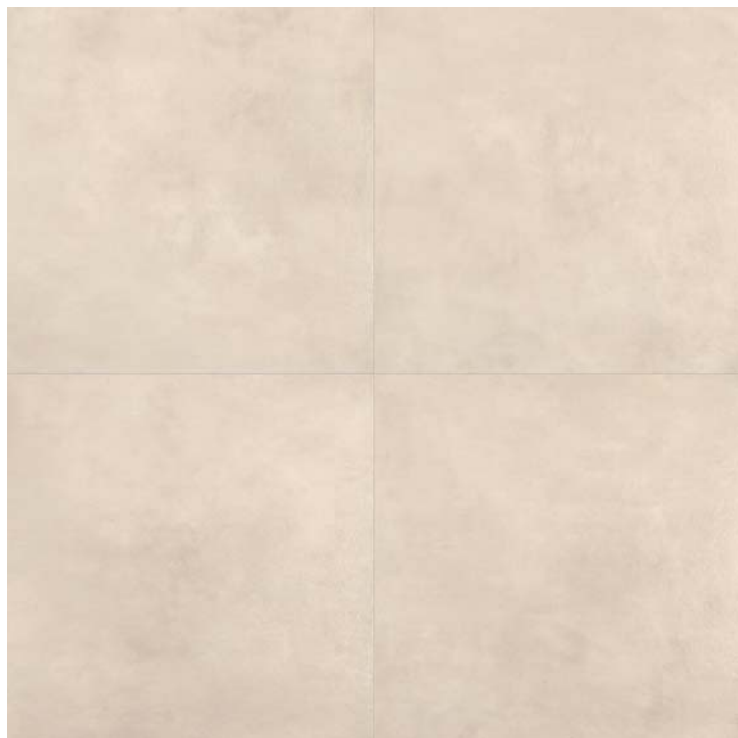

# Level

IVORY

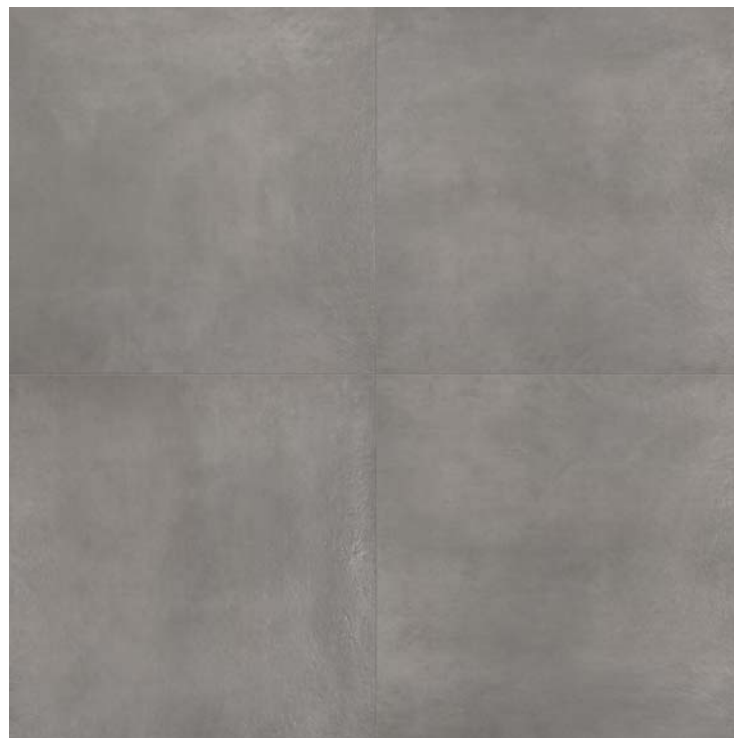

GREY



60,4x60,4  4  
LEVEL IVORY  
**LEN01050** nat. F 33,90

60x60  4  
LEVEL IVORY  
**LER0105A** rett. F 40,90



30x60,4  7  
LEVEL IVORY  
**LEN03050** nat. F 31,90

30x60  7  
LEVEL IVORY  
**LER0305A** rett. F 38,90



30x30  6  
MOS. QUADRETTI LEVEL IVORY  
**LER09051** F 101,90



30x30  4  
MOS. BRICK LEVEL IVORY/GREY  
**LER09052** rett. PZ 17,90

1,5x60  2  
MATITA METAL  
**DWR01001** rett. PZ 15,90



60,4x60,4  4  
LEVEL GREY  
**LEN01150** nat. F 33,90

60x60  4  
LEVEL GREY  
**LER0115A** rett. F 40,90



30x60,4  7  
LEVEL GREY  
**LEN03150** nat. F 31,90

30x60  7  
LEVEL GREY  
**LER0315A** rett. F 38,90



30x30  6  
MOS. QUADRETTI LEVEL GREY  
**LER09151** F 101,90



30x30  4  
MOS. BRICK LEVEL IVORY/GREY  
**LER09052** rett. PZ 17,90

1,5x60  2  
MATITA METAL  
**DWR01001** rett. PZ 15,90

## SILVER

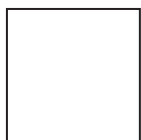
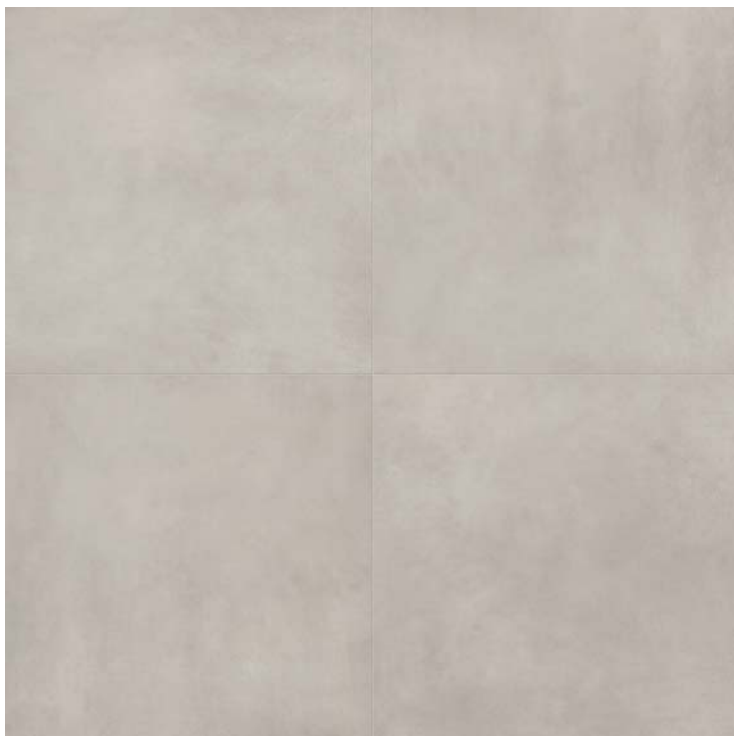

60,4x60,4  4  
LEVEL SILVER  
**LEN01100** nat. F 33,90

60x60  4  
LEVEL SILVER  
**LER0110A** rett. F 40,90



30x60,4  7  
LEVEL SILVER  
**LEN03100** nat. F 31,90

30x60  7  
LEVEL SILVER  
**LER0310A** rett. F 38,90



30x30  6  
MOS. QUADRETTI LEVEL SILVER  
**LER09101** rett. F 101,90



30x30  4  
MOS. BRICK LEVEL SILVER/BLACK  
**LER09102** rett. PZ 17,90

1,5x60  2  
MATITA METAL  
**DWR01001** rett. PZ 15,90

## BLACK

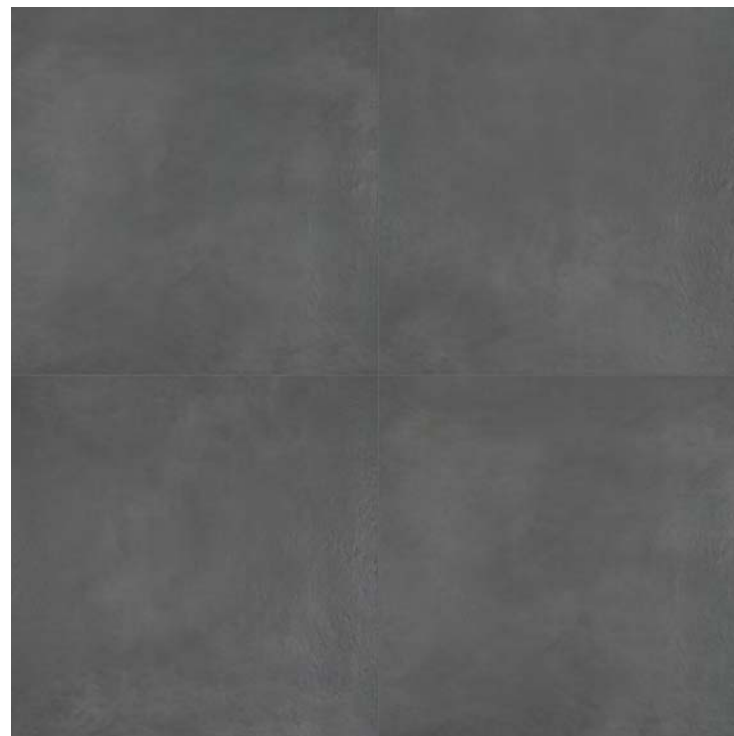

60,4x60,4  4  
LEVEL BLACK  
**LEN01200** nat. F 33,90

60x60  4  
LEVEL BLACK  
**LER0120A** rett. F 40,90



30x60,4  7  
LEVEL BLACK  
**LEN03200** nat. F 31,90

30x60  7  
LEVEL BLACK  
**LER0320A** rett. F 38,90



30x30  6  
MOS. QUADRETTI LEVEL BLACK  
**LER09201** rett. F 101,90



30x30  4  
MOS. BRICK LEVEL SILVER/BLACK  
**LER09102** rett. PZ 17,90

1,5x60  2  
MATITA METAL  
**DWR01001** rett. PZ 15,90

# Level



floor. Ivory 60x60 - Grey 30x60





# Level

## PEZZI SPECIALI / SPECIAL TRIMS

		LEVEL IVORY	LEVEL GREY	LEVEL SILVER	LEVEL BLACK
	BATTISCOPA 6,5x60,4 PZ 7,90  10	<b>LEN01051</b>	<b>LEN01151</b>	<b>LEN01101</b>	<b>LEN01201</b>

## IMBALLI/PACKAGING



F.to nominale Nominal size	F.to reale (mm) Real size (mm)	Spessore Thickness	Pz/Scatola Pcs/Box	Mq/Scatola Sqm/Box	Kg/Scatola Kg/Box	Scatole/Imballo Box/Packing	Mq totali Sqm total	Kg totali Kg total
60,4x60,4 / 24"x24" nat.	-	9 mm	4	1,46	25,55	32	46,72	818
60x60 / 24"x24" rett.	595x595	9 mm	4	1,44	25,20	32	46,08	806
30x60,4 / 12"x24" nat.	-	9 mm	7	1,27	22,23	40	50,80	889
30x60 / 12"x24" rett.	296x595	9 mm	7	1,26	22,05	40	50,40	882

L'unità minima di vendita per tutti gli articoli (fondi, decori e pezzi speciali) è la scatola completa. / The minimum sales quantity for all items (plain tiles, decorations and special trims) is one full box.  
I dati relativi agli imballi sono aggiornati al momento della stampa del catalogo e pertanto possono subire variazioni nel corso del tempo. /

Data referring to packaging have been update at time of printing; the actual data may be slightly different.

Pezzi speciali e decori per effetto delle lavorazioni, possono presentare variazioni di tonalità. / Due to working process special trims and decors, may show variation in tonality.

## SIGILLANTI COORDINATI PER FUGHE / COORDINATED GROUT SEALANTS

LEVEL	COLORE SIGILLANTE SEALANT COLOUR	CODICE SIGILLANTE SEALANT CODE
Level Ivory		SI120B kromos grigio luce
Level Grey - Black		SI122B kromos antracite
Level Silver		SI121B kromos cemento

## COLLANTI / ADHESIVES

	
Bauflex Bianco AD200M Bauflex Grigio AD210M	Baurapid Grigio AD240M

Per una migliore resa estetica e tecnica ABK consiglia l'utilizzo di sigillanti e collanti HARDKOLL come da tabella. Per listino, scheda tecnica e approfondimenti vedi pag. 370  
ABK suggests Hardkoll sealants and adhesives for a better aesthetics and technical efficiency, as follow. Read more at page 370 for prices and technical data sheets.

**WIDE**  
SUPERSIZE SLABS

## LASTRE IN GRES PORCELLANATO PRESSATO A SECCO

DRY-PRESSED PORCELAIN STONEWARE SLABS

### SUPERFICI SURFACES

lux<sup>+</sup> - polished  
naturale - natural

### FORMATI SIZES

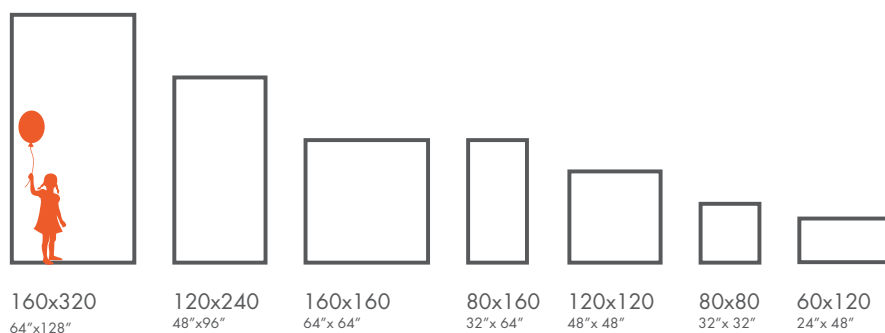

7 mm

Classificazione secondo norme UNI EN 14411 (ISO 13006) Allegato G Gruppo Bla  
Classification in accordance with UNI EN 14411 (ISO 13006) Annex G-Group Bla





**ONICE BEIGE**



**CALACATTA GOLD**



**SAHARA CREAM**



**ARABESQUE SILVER**



**STATUARIO ULTRA**



**PIETRA GREY**

# Sensi

**wall.** Onice Beige LUX\* rett. 160x320 ( Book Match ) - Pietra Grey LUX\* rett. 160x320 - Crossroad Chalk Sand 160x320

**floor.** Onice Beige LUX\* rett. 160x160 - Pietra Grey LUX\* rett. 160x160







**Sensi** floor. Arabesque Silver LUX+ 160x320 (**volumes**). Pietra Grey LUX+ 160x320 - Statuario Ultra LUX+ 160x320





wall. Sahara Cream LUX+ 160x320 floor. Sahara Cream LUX+ 120x120



# Sensi

ONICE BEIGE

**WIDE**  
SUPERSIZE SLABS

7 mm  
▼  
▲

160x320 LUX+ rett.	<b>0000372</b>	F 220,90
120x240 LUX+ rett.	<b>0000384</b>	F 168,90
160x160 LUX+ rett.	<b>0000378</b>	F 200,90
120x120 LUX+ rett.	<b>0000390</b>	F 138,90
60x120 LUX+ rett.	<b>0000742</b>	F 88,90



BOOK MATCH

SLAB A

SLAB B

160x320 SLAB A LUX+ rett.	<b>0000423</b>	F 220,90
160x320 SLAB B LUX+ rett.	<b>0000424</b>	F 220,90

BATTISCOPIA LUX+ rett.  
5,5x120 ☞ 6

**0000872**

PZ 12,90



GRADONE TOP LUX+ rett.  
32x120x4,5x1,5 ☞ 1

**0000878**

PZ 182,90

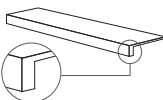

ANG. TOP SX LUX+ rett.  
32x120x4,5x1,5 ☞ 1

**0000884**

PZ 208,90



ANG. TOP DX LUX+ rett.  
32x120x4,5x1,5 ☞ 1

**0000890**

PZ 208,90





# Sensi

CALACATTA GOLD

**WIDE**  
SUPERSIZE SLABS

7 mm  
▲▼

160x320 LUX+ rett.	<b>0000367</b>	F 220,90
120x240 LUX+ rett.	<b>0000379</b>	F 168,90
160x160 LUX+ rett.	<b>0000373</b>	F 200,90
120x120 LUX+ rett.	<b>0000385</b>	F 138,90
80x80 LUX+ rett.	<b>0000717</b>	F 88,90
80x160 rett.	<b>0000732</b>	F 102,90
80x80 rett.	<b>0000736</b>	F 68,90

BATTISCOPA LUX+ rett.  
5,5x120  6

**0000867**

PZ 12,90



GRADONE TOP LUX+ rett.  
32x120x4,5x1,5  1

**0000873**

PZ 182,90

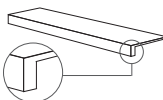

ANG. TOP SX LUX+ rett.  
32x120x4,5x1,5  1

**0000879**

PZ 208,90



ANG. TOP DX LUX+ rett.  
32x120x4,5x1,5  1

**0000885**

PZ 208,90



# Sensi

SAHARA CREAM

**WIDE**  
SUPERSIZE SLABS

7 mm  
▼  
▲

160x320 LUX+ rett.	<b>0000368</b>	F 220,90
120x240 LUX+ rett.	<b>0000380</b>	F 168,90
160x160 LUX+ rett.	<b>0000374</b>	F 200,90
120x120 LUX+ rett.	<b>0000386</b>	F 138,90
80x80 LUX+ rett.	<b>0000740</b>	F 88,90
80x160 rett.	<b>0000733</b>	F 102,90
80x80 rett.	<b>0000737</b>	F 68,90

BATTISCOPIA LUX+ rett.  
5,5x120  6

**0000868**

PZ 12,90



GRADONE TOP LUX+ rett.  
32x120x4,5x1,5  1

**0000874**

PZ 182,90

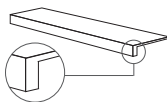

ANG. TOP SX LUX+ rett.  
32x120x4,5x1,5  1

**0000880**

PZ 208,90



ANG. TOP DX LUX+ rett.  
32x120x4,5x1,5  1

**0000886**

PZ 208,90



# Sensi

ARABESQUE SILVER

**WIDE**  
SUPERSIZE SLABS

7 mm

160x320 LUX+ rett.	<b>0000369</b>	F 220,90
120x240 LUX+ rett.	<b>0000381</b>	F 168,90
160x160 LUX+ rett.	<b>0000375</b>	F 200,90
120x120 LUX+ rett.	<b>0000387</b>	F 138,90

BATTISCOPA LUX+ rett.  
5,5x120  6

**0000869** PZ 12,90



GRADONE TOP LUX+ rett.  
32x120x4,5x1,5  1

**0000875** PZ 182,90

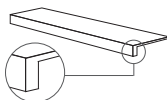

ANG. TOP SX LUX+ rett.  
32x120x4,5x1,5  1

**0000881** PZ 208,90



ANG. TOP DX LUX+ rett.  
32x120x4,5x1,5  1

**0000887** PZ 208,90



# Sensi

STATUARIO ULTRA

**WIDE**  
SUPERSIZE SLABS

7 mm  
▲▼

160x320 LUX+ rett.	<b>0000371</b>	F 220,90
120x240 LUX+ rett.	<b>0000383</b>	F 168,90
160x160 LUX+ rett.	<b>0000377</b>	F 200,90
120x120 LUX+ rett.	<b>0000389</b>	F 138,90
80x80 LUX+ rett.	<b>0000718</b>	F 88,90
80x160 rett.	<b>0000735</b>	F 102,90
80x80 rett.	<b>0000739</b>	F 68,90

BATTISCOPA LUX+ rett.  
5,5x120 ☞ 6

**0000871**

PZ 12,90



GRADONE TOP LUX+ rett.  
32x120x4,5x1,5 ☞ 1

**0000877**

PZ 182,90

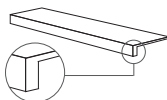

ANG. TOP SX LUX+ rett.  
32x120x4,5x1,5 ☞ 1

**0000883**

PZ 208,90



ANG. TOP DX LUX+ rett.  
32x120x4,5x1,5 ☞ 1

**0000889**

PZ 208,90





# Sensi

PIETRA GREY

**WIDE**  
SUPERSIZE SLABS

7 mm  
▲▼

160x320 LUX+ rett.	<b>0000370</b>	F 220,90
120x240 LUX+ rett.	<b>0000382</b>	F 168,90
160x160 LUX+ rett.	<b>0000376</b>	F 200,90
120x120 LUX+ rett.	<b>0000388</b>	F 138,90
80x80 LUX+ rett.	<b>0000741</b>	F 88,90
80x160 rett.	<b>0000734</b>	F 102,90
80x80 rett.	<b>0000738</b>	F 68,90

BATTISCOPA LUX+ rett.  
5,5x120 ☞ 6

**0000870**

PZ 12,90



GRADONE TOP LUX+ rett.  
32x120x4,5x1,5 ☞ 1

**0000876**

PZ 182,90

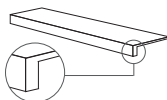

ANG. TOP SX LUX+ rett.  
32x120x4,5x1,5 ☞ 1

**0000882**

PZ 208,90



ANG. TOP DX LUX+ rett.  
32x120x4,5x1,5 ☞ 1

**0000888**

PZ 208,90



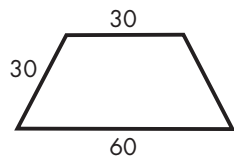

TRAPEZIO 9  
60x30x30

ONICE BEIGE LUX+ rett.	<b>0000896</b>	F 239,90
CALACATTA GOLD LUX+ rett.	<b>0000891</b>	F 239,90
SAHARA CREAM LUX+ rett.	<b>0000892</b>	F 239,90
ARABESQUE SILVER LUX+ rett.	<b>0000893</b>	F 239,90
STATUARIO ULTRA LUX+ rett.	<b>0000895</b>	F 239,90
PIETRA GREY LUX+ rett.	<b>0000894</b>	F 239,90

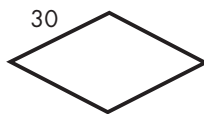

ROMBO 30 13

ONICE BEIGE LUX+ rett.	<b>0000902</b>	F 239,90
CALACATTA GOLD LUX+ rett.	<b>0000897</b>	F 239,90
SAHARA CREAM LUX+ rett.	<b>0000898</b>	F 239,90
ARABESQUE SILVER LUX+ rett.	<b>0000899</b>	F 239,90
STATUARIO ULTRA LUX+ rett.	<b>0000901</b>	F 239,90
PIETRA GREY LUX+ rett.	<b>0000900</b>	F 239,90

## SCHEMI DI POSA - INSTALLATION PATTERNS

### 01 / MONOCOLORE

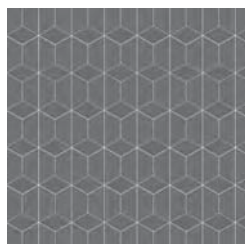

TRAPEZIO col.1 ■ 75 %  
ROMBO col.1 ■ 25 %

### 01.1 / 2 COLORI

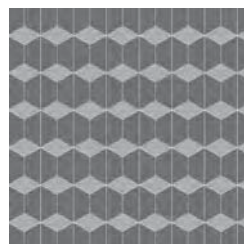

TRAPEZIO col.1 ■ 75 %  
ROMBO col.2 ■ 25 %

### 01.2 / 3 COLORI

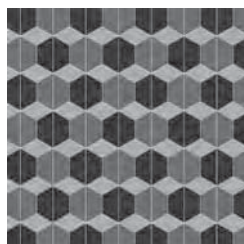

TRAPEZIO col.1 ■ 37,5 %  
ROMBO col.2 ■ 25 %  
TRAPEZIO col.3 ■ 37,5 %

### 01.3 / 3 COLORI

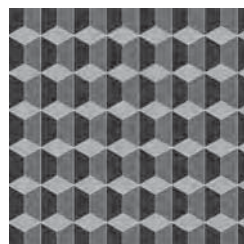

TRAPEZIO col.1 ■ 37,5 %  
ROMBO col.2 ■ 25 %  
TRAPEZIO col.3 ■ 37,5 %

### 02 / MONOCOLORE



TRAPEZIO col.1 ■ 100 %

### 02.1 / 2 COLORI

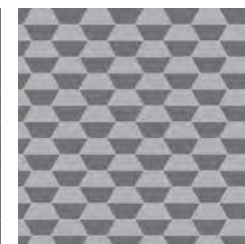

TRAPEZIO col.1 ■ 50 %  
TRAPEZIO col.2 ■ 50 %

### 03 / MONOCOLORE

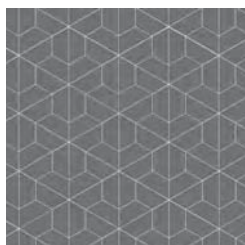

TRAPEZIO col.1 ■ 100 %

### 03.1 / 3 COLORI

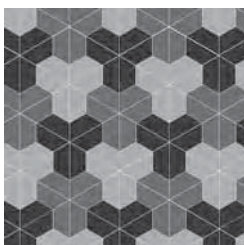

TRAPEZIO col.1 ■ 33,3 %  
TRAPEZIO col.2 ■ 33,3 %  
TRAPEZIO col.3 ■ 33,3 %

### 03.2 / 3 COLORI



TRAPEZIO col.1 ■ 33,3 %  
TRAPEZIO col.2 ■ 33,3 %  
TRAPEZIO col.3 ■ 33,3 %

### 04 / MONOCOLORE



TRAPEZIO col.1 ■ 100 %

### 04.1 / 2 COLORI



TRAPEZIO col.1 ■ 50 %  
TRAPEZIO col.2 ■ 50 %

### 04.2 / 3 COLORI

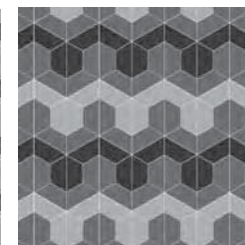

TRAPEZIO col.1 ■ 66,7 %  
TRAPEZIO col.2 ■ 33,3 %  
TRAPEZIO col.3 ■ 33,3 %

### 04.3 / 2 COLORI



TRAPEZIO col.1 ■ 75 %  
TRAPEZIO col.2 ■ 25 %

### 04.4 / 3 COLORI



TRAPEZIO col.1 ■ 37,5 %  
TRAPEZIO col.2 ■ 25 %  
TRAPEZIO col.3 ■ 37,5 %

### 05 / MONOCOLORE

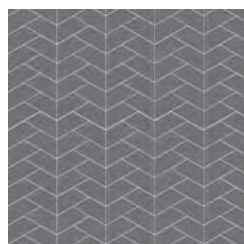

TRAPEZIO col.1 ■ 100 %

### 05.1 / 2 COLORI

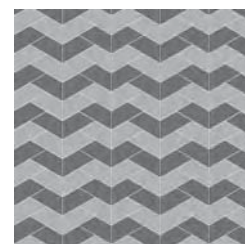

TRAPEZIO col.1 ■ 50 %  
TRAPEZIO col.2 ■ 50 %

### 05.2 / 3 COLORI

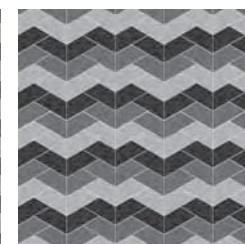

TRAPEZIO col.1 ■ 33,3 %  
TRAPEZIO col.2 ■ 33,3 %  
TRAPEZIO col.3 ■ 33,3 %

# Sensi

**WIDE**  
SUPERSIZE SLABS



30x34  5  
MOS. ENIGMA ONICE BEIGE  
**0000908** LUX+ rett. F 319,90



30x34  5  
MOS. ENIGMA CALACATTA GOLD  
**0000903** LUX+ rett. F 319,90



30x34  5  
MOS. ENIGMA SAHARA CREAM  
**0000904** LUX+ rett. F 319,90



30x34  5  
MOS. ENIGMA ARABESQUE SILVER  
**0000905** LUX+ rett. F 319,90



30x34  5  
MOS. ENIGMA STATUARIO ULTRA  
**0000907** LUX+ rett. F 319,90



30x34  5  
MOS. ENIGMA PIETRA GREY  
**0000906** LUX+ rett. F 319,90

**wall.** Sensi mos. Enigma Statuario ultra LUX+ 30x34



0,5x120  4  
MATITA ALLUMINIO  
**0000086** PZ 20,90



0,5x120  4  
MATITA ALLUMINIO WHITE  
**0000087** PZ 34,90



0,5x120  4  
MATITA ALLUMINIO BLACK  
**0000088** PZ 34,90



0,5x120  4  
MATITA ALLUMINIO RAME  
**0000556** PZ 34,90



0,5x120  4  
MATITA ALLUMINIO BRONZO  
**0000557** PZ 34,90

# Sensi LUX<sup>+</sup>

In genere, la quasi totalità dei manufatti ceramici presenta una superficie compatta facilmente pulibile, in quanto non vi sono punti dove lo sporco può attaccarsi o incastrarsi. Quando la superficie è lavorata, la situazione cambia e spesso si ha una diminuzione drastica della pulibilità accompagnata da un'elevata sensibilità all'attacco acido. Questo fenomeno, tanto più evidente quanto più è chiara la piastrella, è dovuto in gran parte all'emergere di microporosità in cui lo sporco solido, o comunque non solubile in acqua o nei detergenti, si incastra ingrigendo progressivamente la superficie. ABK con LUX<sup>+</sup> introduce un nuovo concetto di finitura superficiale ceramica con cui, tramite un connubio di tecniche applicative e appositi utensili da lavorazione, si può ottenere la completa saturazione della porosità.

In general, the majority of the ceramic tiles presents a compact surface easy to clean, as there are no areas where dirt can attach or get stuck. When the surface is polished, the situation changes and often there is a drastic reduction of the cleanability accompanied by a high sensitivity to acid attack. This phenomenon, the more evident the more it is clear the tile, is due in large part to the appearance of microporosity in which solid dirt, or not soluble in water or in detergents dirt, get stuck and progressively turns the tile surface into gray. ABK introduces LUX<sup>+</sup>, a new concept of ceramic surface finish with which, through a combination of peculiar application techniques and special polishing tools, you can get the complete saturation of the porosity.

## LUX<sup>+</sup>

EXTRA GLOSSY  
EXTRA RESISTANT



### PIÙ LUCIDA

La finitura LUX<sup>+</sup> è in grado di aumentare il livello di lucentezza della superficie oltre i 100 punti di gloss.

### MORE GLOSSY

The finishing LUX<sup>+</sup> is able to increase the level of surface glossiness of more than 100 gloss points.



### PIÙ RESISTENTE

La finitura LUX<sup>+</sup> aumenta la resistenza della superficie alle macchie. Questa è da intendersi sia come ripulibilità della superficie da pedate e macchie di vario genere, sia come resistenza all'attacco acido e all'usura determinata dal calpestio nel tempo.

### MORE RESISTANT

The LUX<sup>+</sup> finishing increases the surface stains resistant. This is to be understood both as cleanability of the surface to treads and stains of various kinds, both as acid and wear resistance determined by the traffic over the time.





## IMBALLI/PACKAGING

F.to nominale Nominal size	F.to reale (mm) Real size (mm)	Spessore Thickness	Tipologia imballo Type of packing	Pz/Imballo Pcs/Packing	Pz/Scatola Pcs/Box	Mq/Scatola Sqm/Box	Kg/Scatola Kg/Box	Scatole/Imballo Box/Packing	Mq totali Sqm total	Kg/Imballo Kg/Packing	Kg totali Kg total	Prezzo imballo Packing Price
160x320 lux+ 64"x128" lux+	1596,5x3195	7 mm	Cassa* Crate	11	-	-	-	-	56,32	139	1.125	€ 130,00
			Cavalletto container* Container Rack pallet	36	-	-	-	-	184,32	180	3.406	€ 235,00
120x240 lux+ 48"x96" lux+	1194x2390	7 mm	Cassa* Crate	20	-	-	-	-	57,60	100	1.109	€ 100,00
			Cavalletto container* Container Rack pallet	36	-	-	-	-	103,68	115	1.930	€ 190,00
160x160 lux+ 64"x64" lux+	1596,5x1596,5	7 mm	Cassa* Crate	22	-	-	-	-	56,32	75	1.061	€ 90,00
			Cavalletto container* Container Rack pallet	36	-	-	-	-	92,16	95	1.708	€ 170,00
120x120 lux+ 48"x48" lux+	1194x1194	7 mm	Pallet con sponde* Pallet white sides*	44	2	2,88	50,40	22	63,36	40	1.149	-
60x120 lux+ 24"x48" lux+	596x1194	7 mm	Europallet*	52	2	1,44	25,20	26	37,44	15	670	-
80x80 lux+/rett. 32"x32" lux+/rett.	797,25x797,25	7 mm	Europallet*	120	3	1,92	33,60	40	76,80	15	1.359	-
80x160 rett. 32"x64" rett.	797,25x1596,5	7 mm	Cavalletto* Rack pallet	56	2	2,56	44,80	28	71,68	70	1.325	€ 50,00

\*Approfondimenti sugli imballi a pag. 378 dell' area tecnica. / Details concerning packaging available at page 378 inside technical area.

L'unità minima di vendita per tutti gli articoli (fondi, decori e pezzi speciali) è la scatola completa. / The minimum sales quantity for all items (plain tiles, decorations and special trims) is one full box.  
I dati relativi agli imballi sono aggiornati al momento della stampa del catalogo e pertanto possono subire variazioni nel corso del tempo. / Data referring to packaging have been update at time of printing; the actual data may be slightly different.  
Pezzi speciali e decori per effetto delle lavorazioni, possono presentare variazioni di tonalità. / Due to working process special trims and decors, may show variation in tonality.

	SIGILLANTI COORDINATI PER FUGHE / COORDINATED GROUT SEALANTS			COLLANTI / ADHESIVES	
	SENSI	COLORE SIGILLANTE SEALANT COLOUR	CODICE SIGILLANTE SEALANT CODE		
	Onice Beige		SI120B kromos grigio luce		
	Calacatta Gold		SI124B kromos bianco		
	Sahara Cream		SI120B kromos grigio luce		
	Arabesque Silver		SI150B kromos perla		
	Statuario Ultra		SI124B kromos bianco		
	Pietra Grey		SI140B kromos nero		
			Baulite S2 Bianco AD340M	+30 Bianco AD330M	
			Baulite S2 Grigio AD341M	+30 Grigio AD331M	

Per una migliore resa estetica e tecnica ABK consiglia l'utilizzo di sigillanti e collanti HARDKOLL come da tabella. Per listino, scheda tecnica e approfondimenti vedi pag. 370  
ABK suggests Hardkoll sealants and adhesives for a better aesthetics and technical efficiency, as follow. Read more at page 370 for prices and technical data sheets.

## GRES PORCELLANATO A MASSA COLORATA

FULL BODY COLORED PORCELAIN STONEWARE

## SUPERFICI SURFACES

lux+ - polished

sablé - natural

## FORMATI SIZES

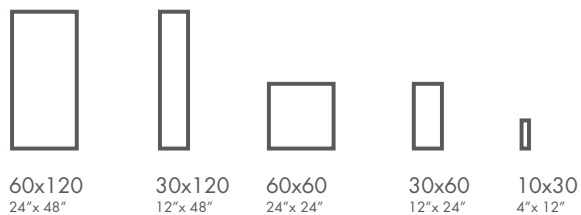

Classificazione secondo norme UNI EN 14411 (ISO 13006) Allegato G Gruppo Bla

Classification in accordance with UNI EN 14411 (ISO 13006) Annex G-Group Bla

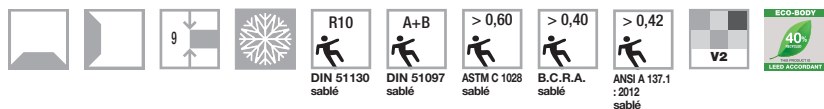



**CALACATTA SELECT**



**SAHARA CREAM**



**ARABESQUE SILVER**



**STATUARIO WHITE**



**PIETRA GREY**

**Sensi** floor. Calacatta Select LUX\* 60x120





wall. Sahara Cream SABLÉ 30x120 / LUX+ 30x120 floor. Sahara Cream SABLÉ 60x120





Sensi floor. Pietra Grey LUX+ 30x120 / SABLÉ 30x120



**wall.** Feel Statuario SABLÈ 30x120, Pietra Grey LUX+ 30x120, Matita alluminio white 0,5x120, Mos. Art Pietra Grey LUX+ 30x30, Mos. Dekor Cold LUX+ 30x30  
**floor.** Statuario White SABLÈ 60x60





# Sensi

CALACATTA SELECT





## LUX+

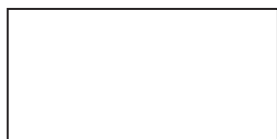

60x120 2  
CALACATTA SELECT  
**1SL34050** lux+ rett. F 88,90



30x120 4  
CALACATTA SELECT  
**1SL57050** lux+ rett. F 88,90



60x60 3  
CALACATTA SELECT  
**1SL01050** lux+ rett. F 75,90



30x60 6  
CALACATTA SELECT  
**1SL03050** lux+ rett. F 69,90



10x30 18  
CALACATTA SELECT  
**1SL11050** lux+ rett. F 88,90



4x30 4  
LONDON CALACATTA SELECT  
**1SL11051** lux+ PZ 17,90



4x3 2  
ANG. LONDON  
**1SL11052** lux+ PZ 20,90



30x30 4  
MOS. ART CALACATTA SELECT  
**1SL09053** lux+ F 252,90



7x60 4  
LIST. CHAINS ORO CALACATTA SEL.  
**ISL03051** lux+ PZ 36,90

(Metallo prezioso: Oro - Precious metal: Gold)



0,5x120 4  
MATITA ALLUMINIO  
**0000086** PZ 20,90

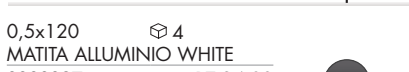

0,5x120 4  
MATITA ALLUMINIO WHITE  
**0000087** PZ 34,90



0,5x120 4  
MATITA ALLUMINIO BLACK  
**0000088** PZ 34,90



1,2x30 4  
RACCORDO CAL. SELECT  
**1SL11053** lux+ PZ 12,90

## SABLÈ

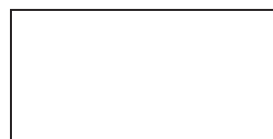

60x120 2  
CALACATTA SELECT  
**1SR34550** sablé rett. F 68,90



30x120 4  
CALACATTA SELECT  
**1SR57550** sablé rett. F 68,90



60x60 3  
CALACATTA SELECT  
**1SR01550** sablé rett. F 53,90

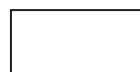

30x60 6  
CALACATTA SELECT  
**1SR03550** sablé rett. F 49,90



30x120 4  
\*\*FEEL CALACATTA SELECT  
**1SR57570** sablé rett. F 81,90



30x30 6  
MOS. QUADR. CAL. SELECT  
**1SR09551** sablé F 101,90



30x30 4  
MOS. CHEVRON CAL. SELECT  
**1SR09552** sablé F 119,90



5x30 4  
\*FASCIA ESSENZE MIX  
**I9R03053** PZ 21,90  
(Legno - Wood)



4x30 4  
\*FASCIA ARDESIA BRONZO  
**RER09054** rett. PZ 20,90  
(Pietra naturale - Natural stone)



1,5x30 4  
FASCIA VETRO BRONZO  
**R1R03157** PZ 22,90  
(Vetro e metalli preziosi -  
Glass and precious metals)

\*\* La non perfetta continuità di linee, rilievi o motivi grafici tra piastrelle adiacenti è naturale conseguenza del processo produttivo, pertanto non costituisce un vizio del prodotto.

\*\* Any variations in graphic designs or textures between adjacent tiles are a natural consequence of the manufacturing process and donot constitute a product defect.

# Sensi

SAHARA CREAM



## LUX+



60x120  2  
SAHARA CREAM  
**1SL34100** lux+ rett. F 88,90

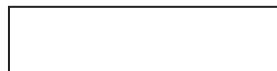

30x120  4  
SAHARA CREAM  
**1SL57100** lux+ rett. F 88,90



60x60  3  
SAHARA CREAM  
**1SL01100** lux+ rett. F 75,90



30x60  6  
SAHARA CREAM  
**1SL03100** lux+ rett. F 69,90



10x30  18  
SAHARA CREAM  
**1SL11100** lux+ rett. F 88,90



4x30  4  
LONDON SAHARA CREAM  
**1SL11101** lux+ PZ 17,90



4x3  2  
ANG. LONDON  
**1SL11102** lux+ PZ 20,90



30x30  4  
MOS. ART SAHARA CREAM  
**1SL09103** lux+ F 252,90



0,5x120  4  
MATITA ALLUMINIO  
**0000086** PZ 20,90



0,5x120  4  
MATITA ALLUMINIO WHITE  
**0000087** PZ 34,90





0,5x120  4  
MATITA ALLUMINIO BLACK  
**0000088** PZ 34,90

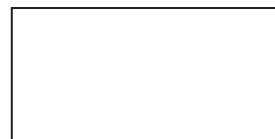

1,2x30  4  
RACCORDO SAH. CREAM  
**1SL11103** lux+ PZ 12,90

## SABLÈ



60x120  2  
SAHARA CREAM  
**1SR34600** sablé rett. F 68,90



30x120  4  
SAHARA CREAM  
**1SR57600** sablé rett. F 68,90



60x60  3  
SAHARA CREAM  
**1SR01600** sablé rett. F 53,90



30x60  6  
SAHARA CREAM  
**1SR03600** sablé rett. F 49,90

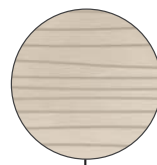

30x120  4  
\*\* FEEL SAHARA CREAM  
**1SR57620** sablé rett. F 81,90



30x30  6  
MOS. QUADR. SAHARA CREAM  
**1SR09601** sablé F 101,90



30x30  4  
MOS. CHEVRON SAHARA CREAM  
**1SR09602** sablé F 119,90



5x30  4  
\* FASCIA ESSENZE MIX  
**1R03053** PZ 21,90  
(Legno - Wood)



4x30  4  
\* FASCIA ARDESIA BRONZO  
**RER09054** rett. PZ 20,90  
(Pietra naturale - Natural stone)



1,5x30  4  
FASCIA VETRO BRONZO  
**R1R03157** PZ 22,90  
(Vetro e metalli preziosi -  
Glass and precious metals)

\*\* La non perfetta continuità di linee, rilievi o motivi grafici tra piastrelle adiacenti è naturale conseguenza del processo produttivo, pertanto non costituisce un vizio del prodotto.

\*\* Any variations in graphic designs or textures between adjacent tiles are a natural consequence of the manufacturing process and donot constitute a product defect.

# Sensi

ARABESQUE SILVER





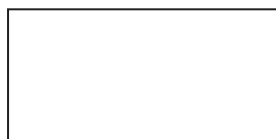

## LUX+

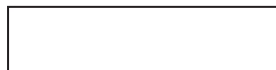

60x120  2  
ARABESQUE SILVER  
**1SL34150** lux+ rett. F 88,90



30x120  4  
ARABESQUE SILVER  
**1SL57150** lux+ rett. F 88,90



60x60  3  
ARABESQUE SILVER  
**1SL01150** lux+ rett. F 75,90



30x60  6  
ARABESQUE SILVER  
**1SL03150** lux+ rett. F 69,90



10x30  18  
ARABESQUE SILVER  
**1SL11150** lux+ rett. F 88,90



4x30  4  
LONDON ARABESQUE SILVER  
**1SL11151** lux+ PZ 17,90



4x3  2  
ANG. LONDON  
**1SL11152** lux+ PZ 20,90

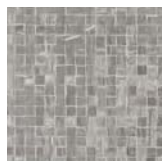

30x30  4  
MOS. ART ARABESQUE SILVER  
**1SL09153** lux+ F 252,90



30x30  4  
MOS. DEKOR COLD  
**1SL09251** lux+ PZ 35,90



0,5x120  4  
MATITA ALLUMINIO  
**0000086** PZ 20,90



0,5x120  4  
MATITA ALLUMINIO WHITE  
**0000087** PZ 34,90

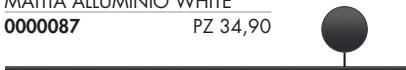

0,5x120  4  
MATITA ALLUMINIO BLACK  
**0000088** PZ 34,90



1,2x30  4  
RACCORDO ARAB. SILVER  
**1SL11153** lux+ PZ 12,90

## SABLÈ



60x120  2  
ARABESQUE SILVER  
**1SR34650** sablè rett. F 68,90



30x120  4  
ARABESQUE SILVER  
**1SR57650** sablè rett. F 68,90



60x60  3  
ARABESQUE SILVER  
**1SR01650** sablè rett. F 53,90

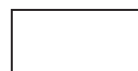

30x60  6  
ARABESQUE SILVER  
**1SR03650** sablè rett. F 49,90



30x30  6  
MOS. QUADR. ARAB. SILVER  
**1SR09651** sablè F 101,90



30x30  4  
MOS. CHEVRON ARAB. SILVER  
**1SR09652** sablè F 119,90



5x30  4  
\* FASCIA ESSENZE MIX  
**19R03053** PZ 21,90  
(Legno - Wood)



4x30  4  
\* FASCIA ARDESIA GRIGIO  
**RER09204** rett. PZ 20,90  
(Pietra naturale - Natural stone)



1,5x30  4  
FASCIA VETRO PLATINO  
**R1R03207** PZ 22,90



1,5x30  4  
FASCIA VETRO BRONZO  
**R1R03157** PZ 22,90



1,5x30  4  
FASCIA VETRO ORO  
**R1R03106** PZ 22,90  
(Vetro e metalli preziosi -  
Glass and precious metals)

\* Art. realizzati con materiali naturali:  
vedi indicazioni per posa e pulizia a  
pag. 393 dell' area tecnica.  
\* Items produced with natural materials:  
check the technical area at page 393.

# Sensi

STATUARIO WHITE



## LUX+

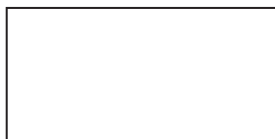

60x120  2  
STATUARIO WHITE  
**1SL34250** lux+ rett. F 88,90



30x120  4  
STATUARIO WHITE  
**1SL57250** lux+ rett. F 88,90

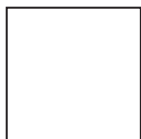

60x60  3  
STATUARIO WHITE  
**1SL01250** lux+ rett. F 75,90



30x60  6  
STATUARIO WHITE  
**1SL03250** lux+ rett. F 69,90



10x30  18  
STATUARIO WHITE  
**1SL11250** lux+ rett. F 88,90



4x30  4  
LONDON ST. WHITE  
**1SL11251** lux+ PZ 17,90



4x3  2  
ANG. LONDON  
**1SL11252** lux+ PZ 20,90



1,2x30  4  
RACCORDO ST. WHITE  
**1SL11253** lux+ PZ 12,90

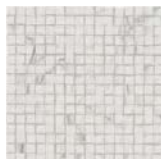

30x30  4  
MOS. ART ST. WHITE  
**1SL09253** lux+ F 252,90



30x30  4  
MOS. DEKOR COLD  
**1SL09251** lux+ PZ 35,90



0,5x120  4  
MATITA ALLUMINIO  
**0000086** PZ 20,90



0,5x120  4  
MATITA ALLUMINIO WHITE  
**0000087** PZ 34,90



0,5x120  4  
MATITA ALLUMINIO BLACK  
**0000088** PZ 34,90

## SABLÈ



60x120  2  
STATUARIO WHITE  
**1SR34750** sablé rett. F 68,90



30x120  4  
STATUARIO WHITE  
**1SR57750** sablé rett. F 68,90



60x60  3  
STATUARIO WHITE  
**1SR01750** sablé rett. F 53,90



30x60  6  
STATUARIO WHITE  
**1SR03750** sablé rett. F 49,90

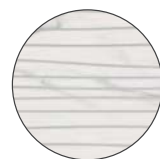

30x120  4  
\*\* FEEL STATUARIO WHITE  
**1SR57770** sablé rett. F 81,90

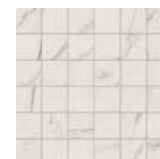

30x30  6  
MOS. QUADR. ST. WHITE  
**1SR09751** sablé F 101,90



30x30  4  
MOS. CHEVRON ST. WHITE  
**1SR09752** sablé F 119,90



5x30  4  
\* FASCIA ESSENZE MIX  
**19R03053** PZ 21,90  
(Legno - Wood)



4x30  4  
\* FASCIA ARDESIA GRIGIO  
**RER09204** rett. PZ 20,90  
(Pietra naturale - Natural stone)



1,5x30  4  
FASCIA VETRO PLATINO  
**R1R03207** PZ 22,90  
(Vetro e metalli preziosi -  
Glass and precious metals)

- \*\* La non perfetta continuità di linee, rilievi o motivi grafici tra piastrelle adiacenti è naturale conseguenza del processo produttivo, pertanto non costituisce un vizio del prodotto.
- \*\* Any variations in graphic designs or textures between adjacent tiles are a natural consequence of the manufacturing process and donot constitute a product defect.

\* Art. realizzati con materiali naturali: vedi indicazioni per posa e pulizia a pag. 393 dell' area tecnica.  
\* Items produced with natural materials: check the technical area at page 393.

# Sensi

PIETRA GREY

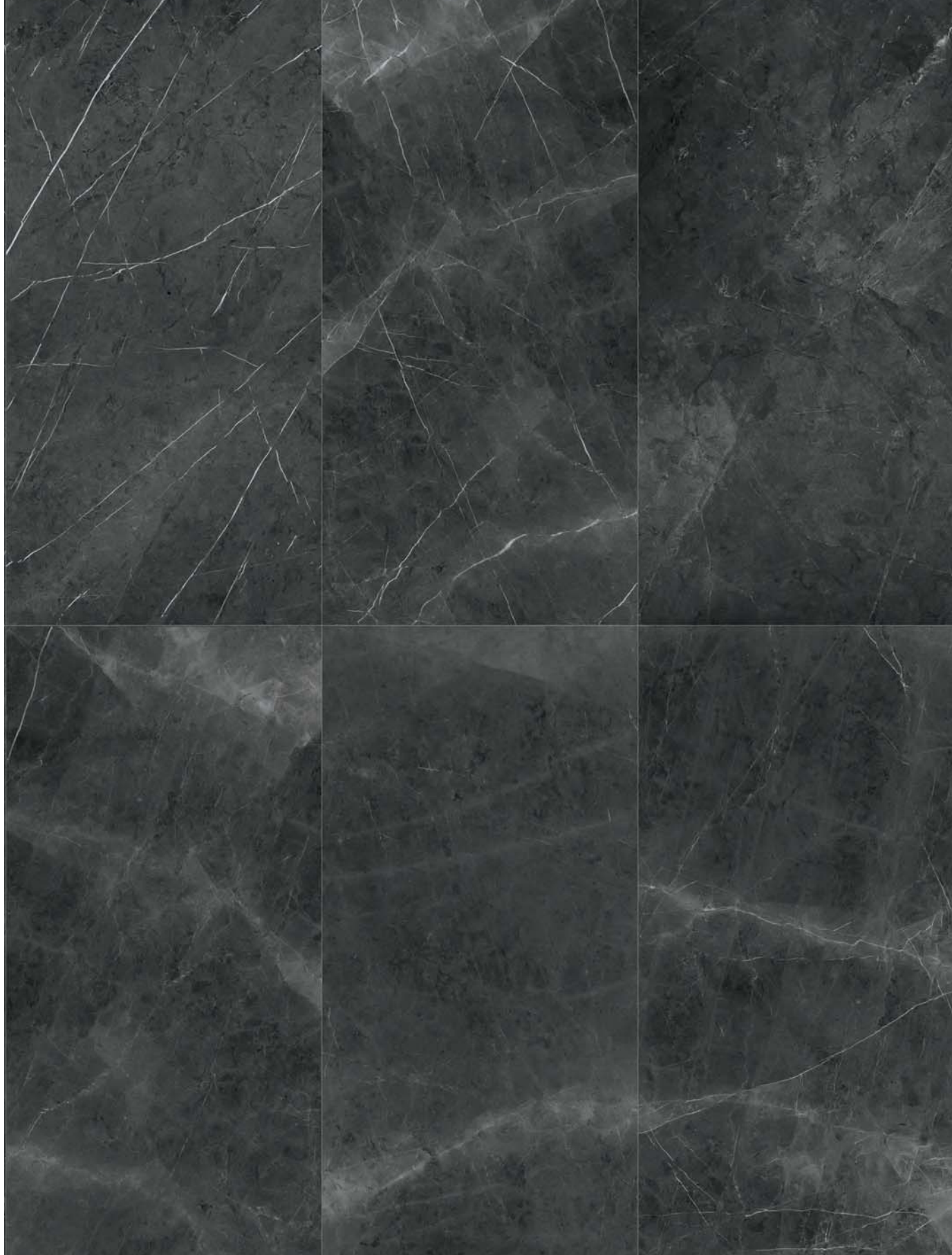



## LUX+

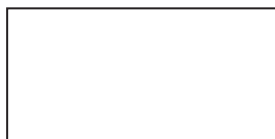

60x120  2  
PIETRA GREY  
**1SL34200** lux+ rett. F 88,90



30x120  4  
PIETRA GREY  
**1SL57200** lux+ rett. F 88,90

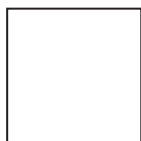

60x60  3  
PIETRA GREY  
**1SL01200** lux+ rett. F 75,90



30x60  6  
PIETRA GREY  
**1SL03200** lux+ rett. F 69,90



10x30  18  
PIETRA GREY  
**1SL11200** lux+ rett. F 88,90



4x30  4  
LONDON PIETRA GREY  
**1SL11201** lux+ PZ 17,90



4x3  2  
ANG. LONDON  
**1SL11202** lux+ PZ 20,90



30x30  4  
MOS. ART PIETRA GREY  
**1SL09203** lux+ F 252,90



30x30  4  
MOS. DEKOR COLD  
**1SL09251** lux+ PZ 35,90



7x60  4  
LIST. CHAINS ORO PIETRA GREY  
**1SL03201** lux+ PZ 36,90

(Metallo prezioso: Oro - Precious metal: Gold)



0,5x120  4  
MATITA ALLUMINIO  
**0000086** PZ 20,90



0,5x120  4  
MATITA ALLUMINIO WHITE  
**0000087** PZ 34,90



0,5x120  4  
MATITA ALLUMINIO BLACK  
**0000088** PZ 34,90

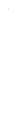

1,2x30  4  
RACCORDO PIETRA GREY  
**1SL11203** lux+ PZ 12,90

## SABLÈ



60x120  2  
PIETRA GREY  
**1SR34700** sablè rett. F 68,90



30x120  4  
PIETRA GREY  
**1SR57700** sablè rett. F 68,90



60x60  3  
PIETRA GREY  
**1SR01700** sablè rett. F 53,90



30x60  6  
PIETRA GREY  
**1SR03700** sablè rett. F 49,90

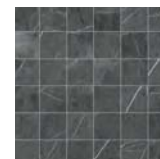

30x30  6  
MOS. QUADR. PIETRA GREY  
**1SR09701** sablè F 101,90



30x30  4  
MOS. CHEVRON PIETRA GREY  
**1SR09702** sablè F 119,90



5x30  4  
\* FASCIA ESSENZE MIX  
**19R03053** PZ 21,90  
(Legno - Wood)



4x30  4  
\* FASCIA ARDESIA GRIGIO  
**RER09204** rett. PZ 20,90  
(Pietra naturale - Natural stone)



1,5x30  4  
FASCIA VETRO PLATINO  
**R1R03207** PZ 22,90  
(Vetro e metalli preziosi -  
Glass and precious metals)

\* Art. realizzati con materiali naturali:  
vedi indicazioni per posa e pulizia a  
pag. 393 dell' area tecnica.  
\* Items produced with natural materials:  
check the technical area at page 393.

**Sensi** floor. Arabesque Silver SABLÉ 60x120





## PEZZI SPECIALI / SPECIAL TRIMS

			STATUARIO WHITE	PIETRA GREY	ARABESQUE SILVER	CALACATTA SELECT	SAHARA CREAM
	BATTISCOPA rett. 5,5x60 ☞ 10	PZ 8,90 PZ 8,90	LUX+ 1SL01251 SABLÈ 1SR01751	LUX+ 1SL01201 SABLÈ 1SR01701	LUX+ 1SL01151 SABLÈ 1SR01651	LUX+ 1SL01051 SABLÈ 1SR01551	LUX+ 1SL01101 SABLÈ 1SR01601
	GRADONE TOP rett. 32x120x4,5x2 ☞ 1	PZ 182,90 PZ 172,90	LUX+ 1SL34251 SABLÈ 1SR34751	LUX+ 1SL34201 SABLÈ 1SR34701	LUX+ 1SL34151 SABLÈ 1SR34651	LUX+ 1SL34051 SABLÈ 1SR34551	LUX+ 1SL34101 SABLÈ 1SR34601
	ANG. TOP SX rett. 32x120x4,5x2 ☞ 1	PZ 208,90 PZ 198,90	LUX+ 1SL34252 SABLÈ 1SR34752	LUX+ 1SL34202 SABLÈ 1SR34702	LUX+ 1SL34152 SABLÈ 1SR34652	LUX+ 1SL34052 SABLÈ 1SR34552	LUX+ 1SL34102 SABLÈ 1SR34602
	ANG. TOP DX rett. 32x120x4,5x2 ☞ 1	PZ 208,90 PZ 198,90	LUX+ 1SL34253 SABLÈ 1SR34753	LUX+ 1SL34203 SABLÈ 1SR34703	LUX+ 1SL34153 SABLÈ 1SR34653	LUX+ 1SL34053 SABLÈ 1SR34553	LUX+ 1SL34103 SABLÈ 1SR34603

## IMBALLI/PACKAGING

F.to nominale Nominal size	F.to reale (mm) Real size (mm)	Spessore Thickness	Pz/Scatola Pcs/Box	Mq/Scatola Sqm/Box	Kg/Scatola Kg/Box	Scatole/Imballo Box/Packing	Mq totali Sqm total	Kg totali Kg total
60x120 / 24"x48" rett.	596x1194	9 mm	2	1,44	27,20	26	37,44	748
30x120 / 12"x48" rett.	297x1194	9 mm	4	1,44	27,20	18	25,92	509
*60x60 / 24"x24" rett.	596x596	9 mm	3	1,08	21,20	40	43,20	868
*30x60 / 12"x24" rett.	297x596	9 mm	6	1,08	21,20	40	43,20	868
*10x30 / 4"x12" rett.	97,6x297	9 mm	18	0,54	11,60	64	34,56	763

L'unità minima di vendita per tutti gli articoli (fondi, decori e pezzi speciali) è la scatola completa. / The minimum sales quantity for all items (plain tiles, decorations and special trims) is one full box.  
I dati relativi agli imballi sono aggiornati al momento della stampa del catalogo e pertanto possono subire variazioni nel corso del tempo. /  
Data referring to packaging have been update at time of printing; the actual data may be slightly different.  
Pezzi speciali e decori per effetto delle lavorazioni, possono presentare variazioni di tonalità. / Due to working process special trims and decors, may show variation in tonality.

	SIGILLANTI COORDINATI PER FUGHE / COORDINATED GROUT SEALANTS		COLLANTI / ADHESIVES		
	SENSI	COLORE SIGILLANTE SEALANT COLOUR	CODICE SIGILLANTE SEALANT CODE		
	Onice Beige		SI120B kromos grigio luce		
	Calacatta Select		SI124B kromos bianco	* Vedi tabella imballi / * See at packaging list	
	Sahara Cream		SI120B kromos grigio luce	Bauflex Bianco AD200M	+30 Bianco AD330M
	Arabesque Silver		SI150B kromos perla	Bauflex Grigio AD210M	+30 Grigio AD331M
	Statuario White		SI124B kromos bianco		
	Pietra Grey		SI140B kromos nero		

Per una migliore resa estetica e tecnica ABK consiglia l'utilizzo di sigillanti e collanti HARDKOLL come da tabella. Per listino, scheda tecnica e approfondimenti vedi pag. 370  
ABK suggests Hardkoll sealants and adhesives for a better aesthetics and technical efficiency, as follow. Read more at page 370 for prices and technical data sheets.

# Grace

---

**GRES PORCELLANATO**  
PORCELAIN STONEWARE

**SUPERFICI** SURFACES

lappato - honed

**FORMATI** SIZES



60x60  
24"x 24"



10 mm

---

Classificazione secondo norme UNI EN 14411 (ISO 13006) Allegato G Gruppo B1a GL  
Classification in accordance with UNI EN 14411 (ISO 13006) Annex G-Group B1a GL

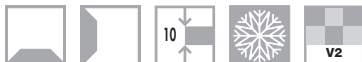



A close-up view of Alabastro marble, showing a light beige background with subtle, wispy veins of a slightly darker beige color.

**ALABASTRO**

A close-up view of Marmor marble, featuring a light beige base with prominent, irregular veins of a darker beige or light brown color.

**MARFIL**

A close-up view of Pulpis Grigio marble, characterized by a dark grey background with intricate, light-colored veins that create a complex, organic pattern.

**PULPIS GRIGIO**

A close-up view of Statuario marble, showing a light beige background with bold, dark brown veins that form a striking, dramatic pattern.

**STATUARIO**

# Grace

floor. Pulpis Grigio 60x60 lapp. extra rett.





floor. Marfil 60x60 lapp. extra rett.



# Grace

ALABASTRO

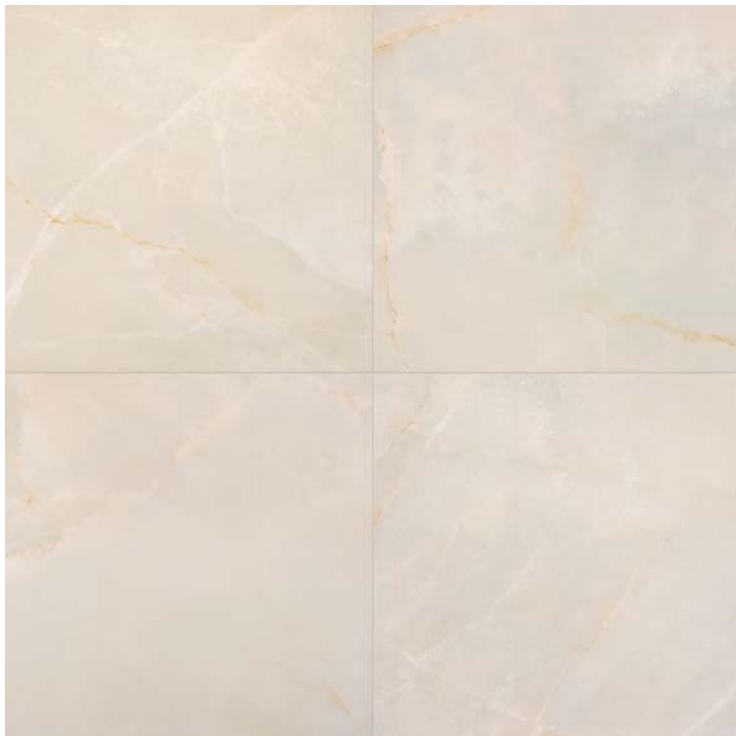

MARFIL

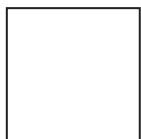

60x60  3  
◆ GRACE ALABASTRO lapp. extra  
**GRL01100** rett. F 64,90

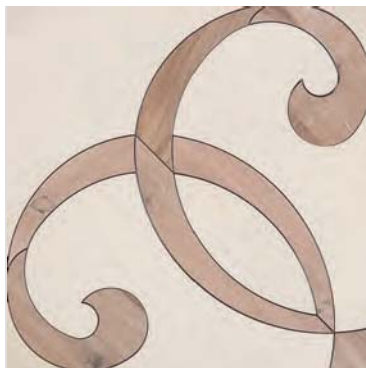

60x60  2  
◆ DEC. INTARSIO ALABASTRO  
**GRL01102** rett. PZ 199,90  
(ALABASTRO - SOLERAS AVANA)



60x60  3  
◆ GRACE MARFIL lapp. extra  
**GRL01250** rett. F 64,90



60x60  2  
◆ DEC. INTARSIO MARFIL  
**GRL01252** rett. PZ 199,90  
(MARFIL - SOLERAS AVANA)



# Grace

## PULPIS GRIGIO



60x60  3  
 ◆ GRACE PULPIS GRIGIO lapp. extra  
**GRL01200** rett. F 64,90

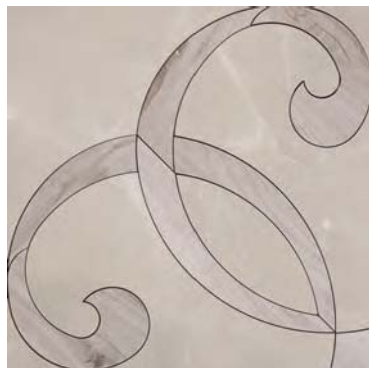

60x60  2  
 ◆ DEC. INTARSIO PULPIS GRIGIO  
**GRL01202** rett. PZ 199,90

(PULPIS GRIGIO - SOLERAS GRIGIO)

## STATUARIO



60x60  3  
 ◆ GRACE STATUARIO lapp. extra  
**GRL01050** rett. F 64,90

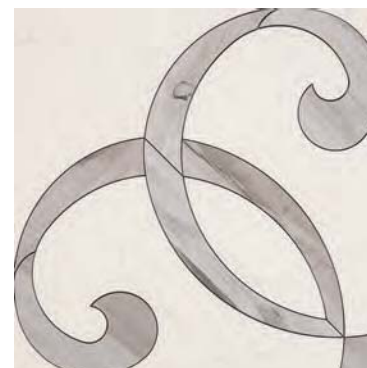

60x60  2  
 ◆ DEC. INTARSIO STATUARIO  
**GRL01052** rett. PZ 199,90

(STATUARIO - SOLERAS GRIGIO)

### ◆ LAPPATO EXTRA

È un trattamento protettivo brevettato specifico per superfici ceramiche lappate a campo pieno realizzato con tecnologia e materiali di ultima generazione. Applica una protezione invisibile che lascia inalterate nel tempo le caratteristiche estetiche del prodotto e l'elevato grado di lucentezza. È resistente alle macchie ed allo sporco.

Si pulisce con grande facilità e non richiede particolare manutenzione.

La manutenzione ordinaria deve essere eseguita con prodotti neutri, privi di cere o patine lucidanti, per non togliere al pavimento l'originale lucentezza derivata dal trattamento.

It's a patented protective treatment for specific glossy polished ceramic surfaces realized with the latest technology and materials.

Applies an invisible protection that maintains the aesthetic characteristics of the product and leaves the high glossy effect.

It's stains and dirt resistant.

Easy to clean and requires no special maintenance.

The ordinary maintenance must be realized with neutral, wax or polishing glaze free products, in order to preserve the original surface glossiness derived from the treatment.

# Grace

floor. Alabastro 60x60 lapp. extra rett.



# Grace

## PEZZI SPECIALI / SPECIAL TRIMS

	ALABASTRO	MARFIL	PULPIS GRIGIO	STATUARIO
 ✦ BATTISCOPA lapp. extra rett. 6,5x60 PZ 8,90    10	<b>GRL01101</b>	<b>GRL01251</b>	<b>GRL01201</b>	<b>GRL01051</b>

## IMBALLI/PACKAGING

F.to nominale Nominal size	F.to reale (mm) Real size (mm)	Spessore Thickness	Pz/Scatola Pcs/Box	Mq/Scatola Sqm/Box	Kg/Scatola Kg/Box	Scatole/Imballo Box/Packing	Mq totali Sqm total	Kg totali Kg total
60x60 / 24"x24" rett.	596x596	10 mm	3	1,08	23,00	40	43,20	940

L'unità minima di vendita per tutti gli articoli (fondi, decori e pezzi speciali) è la scatola completa. / The minimum sales quantity for all items (plain tiles, decorations and special trims) is one full box.  
I dati relativi agli imballi sono aggiornati al momento della stampa del catalogo e pertanto possono subire variazioni nel corso del tempo. / Data referring to packaging have been update at time of printing; the actual data may be slightly different.  
Pezzi speciali e decori per effetto delle lavorazioni, possono presentare variazioni di tonalità. / Due to working process special trims and decors, may show variation in tonality.

## SIGILLANTI COORDINATI PER FUGHE / COORDINATED GROUT SEALANTS

GRACE	COLORE SIGILLANTE SEALANT COLOUR	CODICE SIGILLANTE SEALANT CODE
Grace Marfil		SI129B kromos bahama beige
Grace Alabastro - Pulpis grigio - Statuario		SI120B Kronos grigio luce

## COLLANTI / ADHESIVES

	
Bauflex Bianco AD200M	Baurapid Grigio AD240M
Bauflex Grigio AD210M	

Per una migliore resa estetica e tecnica ABK consiglia l'utilizzo di sigillanti e collanti HARDKOLL come da tabella. Per listino, scheda tecnica e approfondimenti vedi pag. 370  
ABK suggests Hardkoll sealants and adhesives for a better aesthetics and technical efficiency, as follow. Read more at page 370 for prices and technical data sheets.

# Alpes

**WIDE**  
SUPERSIZE SLABS

## LASTRE IN GRES PORCELLANATO PRESSATO A SECCO

DRY-PRESSED PORCELAIN STONEWARE SLABS

## SUPERFICI SURFACES

naturale - natural

## FORMATI SIZES

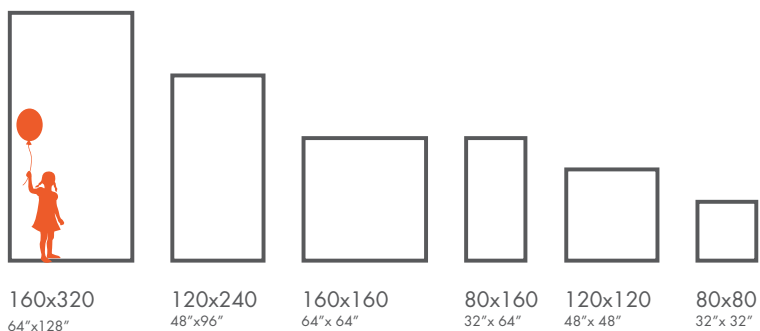

7 mm

Classificazione secondo norme UNI EN 14411 (ISO 13006) Allegato G Gruppo Bla  
Classification in accordance with UNI EN 14411 (ISO 13006) Annex G-Group Bla

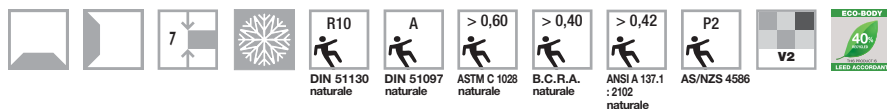





**LEAD**



**GREY**



**IVORY**



**SAND**



# Alpes

wall. pietra grey LUX\* 120x240 - Alpes dec. avantgarde grey 120x240 floor. Alpes grey 120x120 - table. pietra grey LUX\* 160x320







# Alpes

floor. Alpes Sand rett. 160x320





wall. Alpes Lead rett. 80x160 - Alpes mos. Enigma Grey rett. 30x34 - Alpes Grey rett. 160x320 floor. Alpes Lead rett. 80x80



# Alpes

LEAD

**WIDE**  
SUPERSIZE SLABS

7 mm  
▼  
▲

160x320 rett.	<b>0000420</b>	F 168,90
120x240 rett.	<b>0000213</b>	F 132,90
160x160 rett.	<b>0000422</b>	F 152,90
80x160 rett.	<b>0000205</b>	F 102,90
120x120 rett.	<b>0000217</b>	F 102,90
80x80 rett.	<b>0000209</b>	F 68,90

BATTISCOPA rett.  
5,5x80  8

**0000347**

PZ 8,90



GRADONE TOP rett.  
32x120x4,5x1,5  1

**0000351**

PZ 172,90

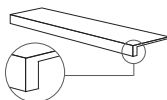

ANG. TOP SX rett.  
32x120x4,5x1,5  1

**0000355**

PZ 198,90



ANG. TOP DX rett.  
32x120x4,5x1,5  1

**0000359**

PZ 198,90





# Alpes

GREY

**WIDE**  
SUPERSIZE SLABS

7 mm  
▼  
▲

160x320 rett.	<b>0000199</b>	F 168,90
120x240 rett.	<b>0000212</b>	F 132,90
160x160 rett.	<b>0000201</b>	F 152,90
80x160 rett.	<b>0000204</b>	F 102,90
120x120 rett.	<b>0000216</b>	F 102,90
80x80 rett.	<b>0000208</b>	F 68,90

BATTISCOPA rett.  
5,5x80  8

**0000346**

PZ 8,90



GRADONE TOP rett.  
32x120x4,5x1,5  1

**0000350**

PZ 172,90

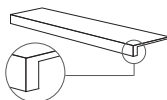

ANG. TOP SX rett.  
32x120x4,5x1,5  1

**0000354**

PZ 198,90



ANG. TOP DX rett.  
32x120x4,5x1,5  1

**0000358**

PZ 198,90



# Alpes

IVORY

**WIDE**  
SUPERSIZE SLABS

7 mm  
▼  
▲

160x320 rett.	<b>0000419</b>	F 168,90
120x240 rett.	<b>0000211</b>	F 132,90
160x160 rett.	<b>0000421</b>	F 152,90
80x160 rett.	<b>0000203</b>	F 102,90
120x120 rett.	<b>0000215</b>	F 102,90
80x80 rett.	<b>0000207</b>	F 68,90

BATTISCOPA rett.  
5,5x80  8

**0000345**

PZ 8,90



GRADONE TOP rett.  
32x120x4,5x1,5  1

**0000349**

PZ 172,90

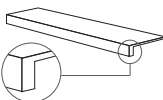

ANG. TOP SX rett.  
32x120x4,5x1,5  1

**0000353**

PZ 198,90



ANG. TOP DX rett.  
32x120x4,5x1,5  1

**0000357**

PZ 198,90





# Alpes

SAND

**WIDE**  
SUPERSIZE SLABS

7 mm  
▼  
▲

160x320 rett.	<b>0000200</b>	F 168,90
120x240 rett.	<b>0000214</b>	F 132,90
160x160 rett.	<b>0000202</b>	F 152,90
80x160 rett.	<b>0000206</b>	F 102,90
120x120 rett.	<b>0000218</b>	F 102,90
80x80 rett.	<b>0000210</b>	F 68,90

BATTISCOPA rett.  
5,5x80  8

**0000348**

PZ 8,90



GRADONE TOP rett.  
32x120x4,5x1,5  1

**0000352**

PZ 172,90

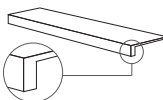

ANG. TOP SX rett.  
32x120x4,5x1,5  1

**0000356**

PZ 198,90



ANG. TOP DX rett.  
32x120x4,5x1,5  1

**0000360**

PZ 198,90



# Alpes



120x240  1  
ALPES DEC. AVANTGARDE SAND  
\*0000295 rett. PZ 1.980,90



120x240  1  
ALPES DEC. AVANTGARDE LEAD  
\*0000294 rett. PZ 1.980,90



120x240  1  
ALPES DEC. AVANTGARDE GREY  
\*0000293 rett. PZ 1.980,90



120x240  1  
ALPES DEC. AVANTGARDE IVORY  
\*0000292 rett. PZ 1.980,90



30x34  5  
ALPES MOS. ENIGMA SAND  
0000291 rett. F 209,90



30x34  5  
ALPES MOS. ENIGMA LEAD  
0000290 rett. F 209,90



30x34  5  
ALPES MOS. ENIGMA GREY  
0000289 rett. F 209,90



30x34  5  
ALPES MOS. ENIGMA IVORY  
0000288 rett. F 209,90



0,5x120  4  
MATITA ALLUMINIO  
0000086 PZ 20,90



0,5x120  4  
MATITA ALLUMINIO WHITE  
0000087 PZ 34,90



0,5x120  4  
MATITA ALLUMINIO BLACK  
0000088 PZ 34,90



0,5x120  4  
MATITA ALLUMINIO RAME  
0000556 PZ 34,90



0,5x120  4  
MATITA ALLUMINIO BRONZO  
0000557 PZ 34,90



# Alpes

## IMBALLI/PACKAGING

F.to nominale Nominal size	F.to reale (mm) Real size (mm)	Spessore Thickness	Tipologia imballo Type of packing	Pz/Imballo Pcs/Packing	Pz/Scatola Pcs/Box	Mq/Scatola Sqm/Box	Kg/Scatola Kg/Box	Scatole/Imballo Box/Packing	Mq totali Sqm total	Kg/Imballo Kg/Packing	Kg totali Kg total	Prezzo imballo Packing Price
160x320 rett. 64"x128" rett.	1596,5x3195	7 mm	Cassa* Crate	11	-	-	-	-	56,32	139	1.125	€ 130,00
			Cavalletto container* Container Rack pallet	36	-	-	-	-	184,32	180	3.406	€ 235,00
120x240 rett. 48"x96" rett.	1194x2390	7 mm	Cavalletto* Rack pallet	40	-	-	-	-	115,20	100	2.116	€ 120,00
			Cavalletto container* Container Rack pallet	36	-	-	-	-	103,68	115	1.930	€ 190,00
160x160 rett. 64"x64" rett.	1596,5x1596,5	7 mm	Cassa* Crate	22	-	-	-	-	56,32	75	1.061	€ 90,00
			Cavalletto container* Container Rack pallet	36	-	-	-	-	92,16	95	1.708	€ 170,00
80x160 rett. 32"x64" rett.	797,25x1596,5	7 mm	Cavalletto* Rack pallet	56	2	2,56	44,80	28	71,68	70	1.325	€ 50,00
120x120 rett. 48"x48" rett.	1194x1194	7 mm	Cavalletto* Rack pallet	56	2	2,88	50,40	28	80,64	70	1.482	€ 50,00
80x80 rett. 32"x32" rett.	797,25x797,25	7 mm	Europallet*	120	3	1,92	33,60	40	76,80	15	1.359	-

\*Approfondimenti sugli imballi a pag. 378 dell' area tecnica. / Details concerning packaging available at page 378 inside technical area.

L'unità minima di vendita per tutti gli articoli (fondi, decori e pezzi speciali) è la scatola completa. / The minimum sales quantity for all items (plain tiles, decorations and special trims) is one full box.  
I dati relativi agli imballi sono aggiornati al momento della stampa del catalogo e pertanto possono subire variazioni nel corso del tempo. / Data referring to packaging have been update at time of printing; the actual data may be slightly different.  
Pezzi speciali e decori per effetto delle lavorazioni, possono presentare variazioni di tonalità. / Due to working process special trims and decors, may show variation in tonality.

	SIGILLANTI COORDINATI PER FUGHE / COORDINATED GROUT SEALANTS			COLLANTI / ADHESIVES	
	ALPES	COLORE SIGILLANTE SEALANT COLOUR	CODICE SIGILLANTE SEALANT CODE		
	Alpes Lead		SI121B kromos cemento		
	Alpes Grey		SI150B kromos perla		
	Alpes Ivory		SI120B kromos grigio luce		
	Alpes Sand		SI120B kromos grigio luce	Baulite S2 Bianco AD340M	+30 Bianco AD330M
			Baulite S2 Grigio AD341M	+30 Grigio AD331M	

Per una migliore resa estetica e tecnica ABK consiglia l'utilizzo di sigillanti e collanti HARDKOLL come da tabella. Per listino, scheda tecnica e approfondimenti vedi pag. 370  
ABK suggests Hardkoll sealants and adhesives for a better aesthetics and technical efficiency, as follow. Read more at page 370 for prices and technical data sheets.

# Alpes Raw

---

## GRES PORCELLANATO A MASSA COLORATA

FULL BODY COLORED PORCELAIN STONEWARE

## SUPERFICI SURFACES

naturale - natural

lappato - honed

## FORMATI SIZES



60x120  
24"x 48"



60x60  
24"x 24"



30x60  
12"x 24"

▼  
9 mm  
▲

---

Classificazione secondo norme UNI EN 14411 (ISO 13006) Allegato G Gruppo Bla

Classification in accordance with UNI EN 14411 (ISO 13006) Annex G-Group Bla



R10  
DIN 51130  
naturale



A+B  
DIN 51097  
naturale



> 0,60  
ASTM C 1028  
naturale



> 0,40  
B.C.R.A.  
naturale



> 0,42  
ANSI A 137.1  
: 2102  
naturale



ECO-BODY  
40%  
LEED ACCORDANT





**LEAD**



**GREY**



**IVORY**



**SAND**



# Alpes Raw

floor. Alpes raw Lead lapp. 60x120





floor. Alpes raw Grey rett. 60x120



# Alpes Raw

**wall.** Alpes raw Sand rett. 30x60 - Alpes raw mos. Quadretti Ivory rett. 30x30 - Alpes raw mos. Quadretti Glam Ivory rett. 30x30 - Sensi Calacatta select sablè rett. 30x60 **floor.** Alpes raw Sand rett. 60x60





wall. Crossroad wood tan 20x120 floor. Alpes raw sand rett. 60x120





# Alpes Raw

LEAD





60x120  2

ALPES RAW LEAD

**0000008** rett. F 68,90

**0000013** lapp rett. F 81,90



60x60  3

ALPES RAW LEAD

**0000018** rett. F 53,90

**0000023** lapp rett. F 64,90



30x60  6

ALPES RAW LEAD

**0000028** rett. F 49,90

**0000033** lapp rett. F 59,90



30x30  6

ALPES RAW MOS. QUAD. LEAD

**0000261** rett. F 101,90



30x60  2

ALPES RAW DEC. SIGN LEAD MIX 2

**0000270** lapp rett. PZ 59,90

(Ottone - brass) (prezzo cad. - price for piece)



30x30  4

\*\* ALPES RAW MOS. QUAD. GLAM LEAD

**0000265** rett. PZ 34,90



10x60  3

\*\* LISTONE WOM

**UKR01161** rett. PZ 34,90



5x60  4

\*\* ALPES RAW LIST. ETHNIC

**0000267** rett. PZ 29,90



5x30  4

\* FASCIA ESSENZE MIX

**I9R03053** PZ 21,90

(Legno/ceramica - wood/ceramic tiles)



4x30  4

\* FASCIA ARDESIA GRIGIO

**RER09204** rett. PZ 20,90

(Pietra naturale - Natural stone)



1,5x30  4

FASCIA VETRO PLATINO

**R1R03207** PZ 22,90



1,5x30  4

FASCIA VETRO BRONZO

**R1R03157** PZ 22,90



0,5x120  4

MATITA ALLUMINIO

**0000086** PZ 20,90

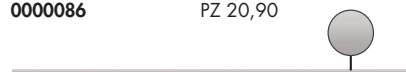

0,5x120  4

MATITA ALLUMINIO WHITE

**0000087** PZ 34,90

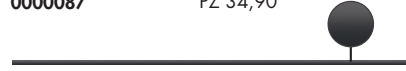

0,5x120  4

MATITA ALLUMINIO BLACK

**0000088** PZ 34,90

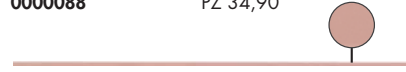

0,5x120  4

MATITA ALLUMINIO RAME

**0000556** PZ 34,90

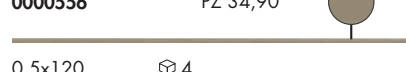

0,5x120  4

MATITA ALLUMINIO BRONZO

**0000557** PZ 34,90

\* Art. realizzati con materiali naturali; vedi indicazioni per posa e pulizia a pag. 393 dell' area tecnica.

\* Items produced with natural materials: check the technical area at page 393.

\*\* Metalli preziosi. Si consiglia di pulire la superficie senza utilizzare prodotti contenenti sostanze abrasive per non alterare la brillantezza del metallo prezioso.  
Precious metal. Do not use products containing abrasive substances to clean the decorative element so as not to affect the shine of the precious metal.



# Alpes Raw

GREY





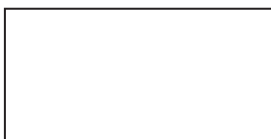

60x120  2

ALPES RAW GREY

**0000007** rett. F 68,90

**0000012** lapp rett. F 81,90



60x60  3

ALPES RAW GREY

**0000017** rett. F 53,90

**0000022** lapp rett. F 64,90



30x60  6

ALPES RAW GREY

**0000027** rett. F 49,90

**0000032** lapp rett. F 59,90



30x30  6

ALPES RAW MOS. QUAD. GREY

**0000260** rett. F 101,90



30x60  2

ALPES RAW DEC. SIGN GREY MIX 2

**0000269** lapp rett. PZ 59,90

(Ottone - brass) (prezzo cad. - price for piece)



30x30  4

\*\* ALPES RAW MOS. QUAD. GLAM GREY

**0000264** rett. PZ 34,90



10x60  3

\*\* LISTONE WOM

**UKR01161** rett. PZ 34,90



5x60  4

\*\* ALPES RAW LIST. ETHNIC

**0000267** rett. PZ 29,90



5x30  4

\* FASCIA ESSENZE MIX

**I9R03053** PZ 21,90

(Legno/ceramica - wood/ceramic tiles)



4x30  4

\* FASCIA ARDESIA GRIGIO

**RER09204** rett. PZ 20,90

(Pietra naturale - Natural stone)



1,5x30  4

FASCIA VETRO PLATINO

**R1R03207** PZ 22,90



1,5x30  4

FASCIA VETRO BRONZO

**R1R03157** PZ 22,90



0,5x120  4

MATITA ALLUMINIO

**0000086** PZ 20,90



0,5x120  4

MATITA ALLUMINIO WHITE

**0000087** PZ 34,90

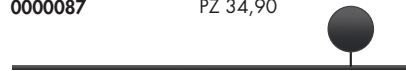

0,5x120  4

MATITA ALLUMINIO BLACK

**0000088** PZ 34,90

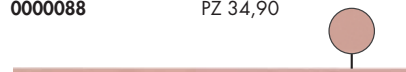

0,5x120  4

MATITA ALLUMINIO RAME

**0000556** PZ 34,90

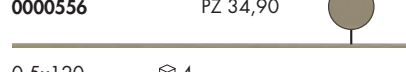

0,5x120  4

MATITA ALLUMINIO BRONZO

**0000557** PZ 34,90

\* Art. realizzati con materiali naturali; vedi indicazioni per posa e pulizia a pag. 393 dell' area tecnica.

\* Items produced with natural materials: check the technical area at page 393.

\*\* Metalli preziosi. Si consiglia di pulire la superficie senza utilizzare prodotti contenenti sostanze abrasive per non alterare la brillantezza del metallo prezioso.  
Precious metal. Do not use products containing abrasive substances to clean the decorative element so as not to affect the shine of the precious metal.

# Alpes Raw

IVORY



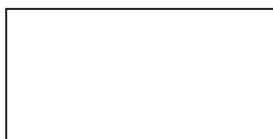

60x120  2

ALPES RAW IVORY

**0000006** rett. F 68,90

**0000011** lapp rett. F 81,90

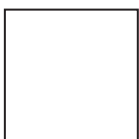

60x60  3

ALPES RAW IVORY

**0000016** rett. F 53,90

**0000021** lapp rett. F 64,90



30x60  6

ALPES RAW IVORY

**0000026** rett. F 49,90

**0000031** lapp rett. F 59,90



30x30  6

ALPES RAW MOS. QUAD. IVORY

**0000259** rett. F 101,90



30x60  2

ALPES RAW DEC. SIGN IVORY MIX 2

**0000268** lapp rett. PZ 59,90

(Ottone - brass) (prezzo cad. - price for piece)

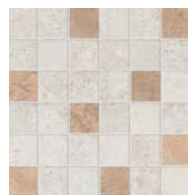

30x30  4

\*\* ALPES RAW MOS. QUAD. GLAM IVORY

**0000263** rett. PZ 34,90



10x60  3

\*\* LISTONE WOM

**UKR01161** rett. PZ 34,90



5x60  4

\*\* ALPES RAW LIST. ETHNIC

**0000267** rett. PZ 29,90



5x30  4

\* FASCIA ESSENZE MIX

**I9R03053** PZ 21,90

(Legno/ceramica - wood/ceramic tiles)



4x30  4

\* FASCIA ARDESIA BRONZO

**RER09054** rett. PZ 20,90

(Pietra naturale - Natural stone)



1,5x30  4

FASCIA VETRO BRONZO

**R1R03157** PZ 22,90



1,5x30  4

FASCIA VETRO ORO

**R1R03106** PZ 22,90

(Vetro e metalli preziosi - Glass and precious metals)



0,5x120  4

MATITA ALLUMINIO

**0000086** PZ 20,90



0,5x120  4

MATITA ALLUMINIO WHITE

**0000087** PZ 34,90

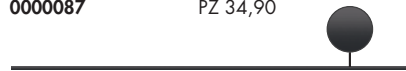

0,5x120  4

MATITA ALLUMINIO BLACK

**0000088** PZ 34,90

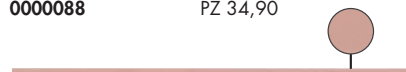

0,5x120  4

MATITA ALLUMINIO RAME

**0000556** PZ 34,90

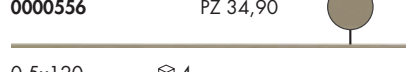

0,5x120  4

MATITA ALLUMINIO BRONZO

**0000557** PZ 34,90

\* Art. realizzati con materiali naturali; vedi indicazioni per posa e pulizia a pag. 393 dell' area tecnica.

\* Items produced with natural materials: check the technical area at page 393.

\*\* Metalli preziosi. Si consiglia di pulire la superficie senza utilizzare prodotti contenenti sostanze abrasive per non alterare la brillantezza del metallo prezioso.  
Precious metal. Do not use products containing abrasive substances to clean the decorative element so as not to affect the shine of the precious metal.



# Alpes Raw

SAND







60x120 2

ALPES RAW SAND

**000009** rett. F 68,90

**000014** lapp rett. F 81,90



60x60 3

ALPES RAW SAND

**000019** rett. F 53,90

**000024** lapp rett. F 64,90



30x60 6

ALPES RAW SAND

**000029** rett. F 49,90

**000034** lapp rett. F 59,90



30x30 6

ALPES RAW MOS. QUAD. SAND

**0000262** rett. F 101,90

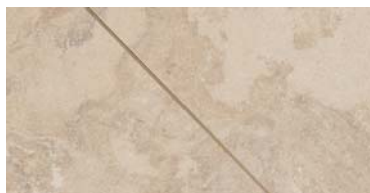
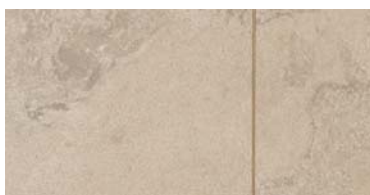

30x60 2

ALPES RAW DEC. SIGN SAND MIX 2

**0000271** lapp rett. PZ 59,90

(Ottone - brass) (prezzo cad. - price for piece)



30x30 4

\*\* ALPES RAW MOS. QUAD. GLAM SAND

**0000266** rett. PZ 34,90



10x60 3

\*\* LISTONE WOM

**UKR01161** rett. PZ 34,90



5x60 4

\*\* ALPES RAW LIST. ETHNIC

**0000267** rett. PZ 29,90



5x30 4

\* FASCIA ESSENZE MIX

**I9R03053** PZ 21,90

(Legno/ceramica - wood/ceramic tiles)



4x30 4

\* FASCIA ARDESIA BRONZO

**RER09054** rett. PZ 20,90

(Pietra naturale - Natural stone)



1,5x30 4

FASCIA VETRO BRONZO

**R1R03157** PZ 22,90



1,5x30 4

FASCIA VETRO ORO

**R1R03106** PZ 22,90

(Vetro e metalli preziosi - Glass and precious metals)



0,5x120 4

MATITA ALLUMINIO

**0000086** PZ 20,90

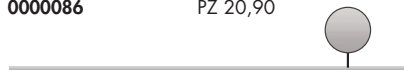

0,5x120 4

MATITA ALLUMINIO WHITE

**0000087** PZ 34,90

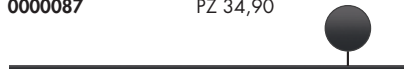

0,5x120 4

MATITA ALLUMINIO BLACK

**0000088** PZ 34,90

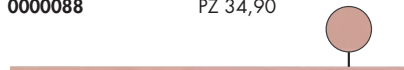

0,5x120 4

MATITA ALLUMINIO RAME

**0000556** PZ 34,90

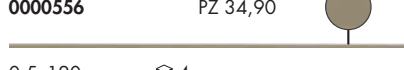

0,5x120 4

MATITA ALLUMINIO BRONZO

**0000557** PZ 34,90

\* Art. realizzati con materiali naturali; vedi indicazioni per posa e pulizia a pag. 393 dell' area tecnica.

\* Items produced with natural materials; check the technical area at page 393.

\*\* Metalli preziosi. Si consiglia di pulire la superficie senza utilizzare prodotti contenenti sostanze abrasive per non alterare la brillantezza del metallo prezioso.  
Precious metal. Do not use products containing abrasive substances to clean the decorative element so as not to affect the shine of the precious metal.

# Alpes Raw

floor. Lead lapp rett. 60x60 - Dec. Sign Lead mix 2 lapp. 30x60



SCHEMA DI POSA  
INSTALLATION PATTERNS

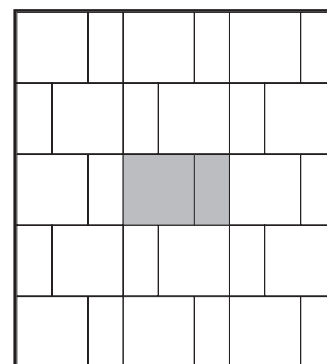

60x60 67 %

30x60 33 %

# Alpes Raw

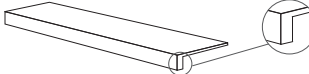
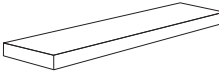
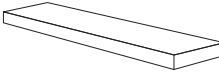

## PEZZI SPECIALI / SPECIAL TRIMS

			LEAD	GREY	IVORY	SAND
	BATTISCOPA rett. 5,5x60 ☞ 10	PZ 7,90	0000274	0000273	0000272	0000275
	ALPES RAW GRADO- NE TOP rett. 32x120x4,5x2 ☞ 1	PZ 172,90	0000278	0000277	0000276	0000279
	ALPES RAW ANG. TOP SX rett. 32x120x4,5x2 ☞ 1	PZ 198,90	0000282	0000281	0000280	0000283
	ALPES RAW ANG. TOP DX rett. 32x120x4,5x2 ☞ 1	PZ 198,90	0000286	0000285	0000284	0000287

## IMBALLI/PACKAGING

F.to nominale Nominal size	F.to reale (mm) Real size (mm)	Spessore Thickness	Pz/Scatola Pcs/Box	Mq/Scatola Sqm/Box	Kg/Scatola Kg/Box	Scatole/Imballo Box/Packing	Mq totali Sqm total	Kg totali Kg total
60x120 / 24"x48" rett.	596x1194	9 mm	2	1,44	27,20	26	37,44	748
*60x60 / 24"x24" rett.	596x596	9 mm	3	1,08	21,20	40	43,20	868
*30x60 / 12"x24" rett.	297x596	9 mm	6	1,08	21,20	40	43,20	868

L'unità minima di vendita per tutti gli articoli (fondi, decori e pezzi speciali) è la scatola completa. / The minimum sales quantity for all items (plain tiles, decorations and special trims) is one full box.  
I dati relativi agli imballi sono aggiornati al momento della stampa del catalogo e pertanto possono subire variazioni nel corso del tempo. /  
Data referring to packaging have been update at time of printing; the actual data may be slightly different.  
Pezzi speciali e decori per effetto delle lavorazioni, possono presentare variazioni di tonalità. / Due to working process special trims and decors, may show variation in tonality.

	SIGILLANTI COORDINATI PER FUGHE / COORDINATED GROUT SEALANTS		COLLANTI / ADHESIVES		
	ALPES	COLORE SIGILLANTE SEALANT COLOUR	CODICE SIGILLANTE SEALANT CODE		
	Alpes Lead		SI121B kromos cemento		
	Alpes Grey		SI150B kromos perla	*Vedi tabella imballi / *See at packaging list	
	Alpes Ivory		SI120B kromos grigio luce	Bauflex Bianco AD200M	+30 Bianco AD330M
Alpes Sand		SI120B kromos grigio luce	Bauflex Grigio AD210M	+30 Grigio AD331M	

Per una migliore resa estetica e tecnica ABK consiglia l'utilizzo di sigillanti e collanti HARDKOLL come da tabella. Per listino, scheda tecnica e approfondimenti vedi pag. 370  
ABK suggests Hardkoll sealants and adhesives for a better aesthetics and technical efficiency, as follow. Read more at page 370 for prices and technical data sheets.

## GRES PORCELLANATO A MASSA COLORATA

FULL BODY COLORED PORCELAIN STONEWARE

## SUPERFICI SURFACES

naturale - natural

antique - honed

bocciardato R11 - structured R11

## FORMATI SIZES

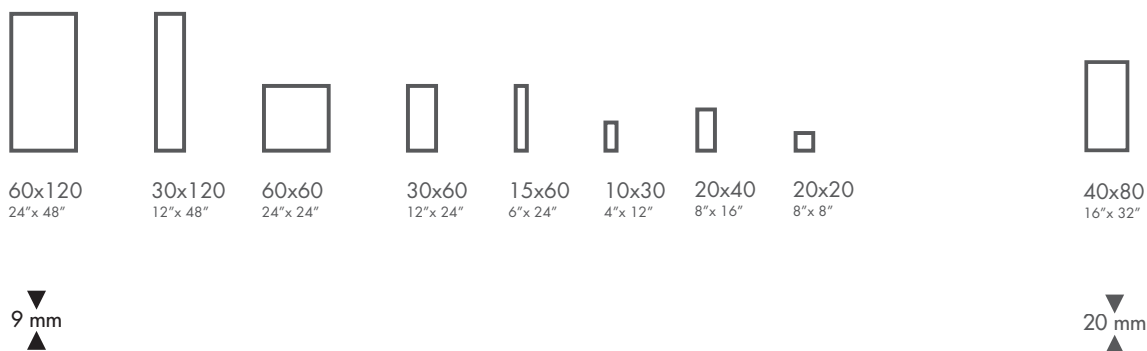

Classificazione secondo norme UNI EN 14411 (ISO 13006) Allegato G Gruppo B1a

Classification in accordance with UNI EN 14411 (ISO 13006) Annex G-Group B1a

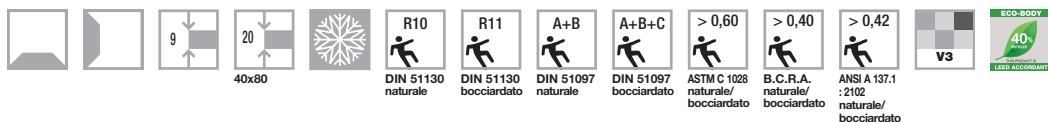





**CREAM**



**ECRU**



**BRONZE**



**GREY**



**SMOKE**



# Unika

floor. Ecrú rett. 60x120 - 30x120 - 60x60 - 30x60



floor. Grey Antique rett. 60x120





# Unika

CREAM







60x120 ☞ 2  
UNIKA CREAM  
**UKR3405A** rett. F 68,90  
**UKL3405A** ANTIQUE rett. F 81,90



30x120 ☞ 4  
UNIKA CREAM  
**UKR57050** rett. F 68,90

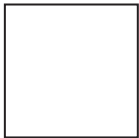

60x60 ☞ 3  
UNIKA CREAM  
**UKN01050** nat. F 46,90  
**UKR01050** rett. F 53,90  
**UKL01050** ANTIQUE rett. F 64,90



30x60 ☞ 6  
UNIKA CREAM  
**UKR03050** rett. F 49,90



10x30 ☞ 18  
UNIKA CREAM  
**UKR11050** rett. F 64,90

#### MIX FLOOR 60x120

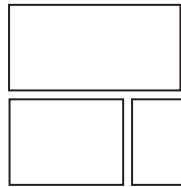

Pcs/Box:  
60x120 ☞ 1  
60x80 ☞ 1  
60x40 ☞ 1

60x120 ☞ 2  
UNIKA CREAM MIX FLOOR  
**UKR3406A** rett. F 81,90

#### MIX WALL 60x80

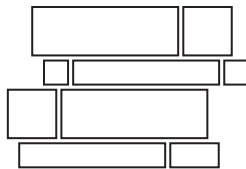

Pcs/Box:  
20x60 ☞ 4  
20x20 ☞ 4  
10x60 ☞ 4  
10x20 ☞ 2  
10x10 ☞ 4

60x80 ☞ 2  
UNIKA CREAM MIX WALL  
**UKR20050** rett. F 74,90

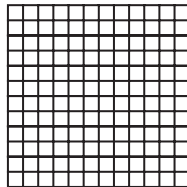

30x30 ☞ 4  
MOS. OPUS MINI CREAM  
**UKR09052** F 252,90

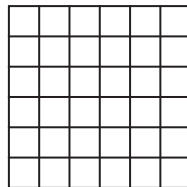

30x30 ☞ 6  
MOS. QUADRETTI CREAM  
**UKR09051** rett. F 101,90

# Unika

ECRU





60x120 ☞ 2  
 UNIKA ECRU  
**UKR3410A** rett. F 68,90  
**UKL3410A** ANTIQUE rett. F 81,90



30x120 ☞ 4  
 UNIKA ECRU  
**UKR57100** rett. F 68,90

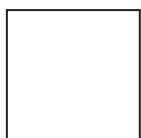

60x60 ☞ 3  
 UNIKA ECRU  
**UKN01100** nat. F 46,90  
**UKR01100** rett. F 53,90  
**UKL01100** ANTIQUE rett. F 64,90



30x60 ☞ 6  
 UNIKA ECRU  
**UKR03100** rett. F 49,90



10x30 ☞ 18  
 UNIKA ECRU  
**UKR11100** rett. F 64,90

### MIX FLOOR 60x120

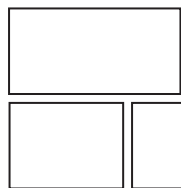

Pcs/Box:  
 60x120 ☞ 1  
 60x80 ☞ 1  
 60x40 ☞ 1

60x120 ☞ 2  
 UNIKA ECRU MIX FLOOR  
**UKR3411A** rett. F 81,90

### MIX WALL 60x80

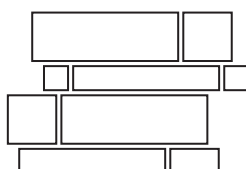

Pcs/Box:  
 20x60 ☞ 4  
 20x20 ☞ 4  
 10x60 ☞ 4  
 10x20 ☞ 2  
 10x10 ☞ 4

60x80 ☞ 2  
 UNIKA ECRU MIX WALL  
**UKR20100** rett. F 74,90

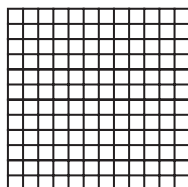

30x30 ☞ 4  
 MOS. OPUS MINI ECRU  
**UKR09102** F 252,90

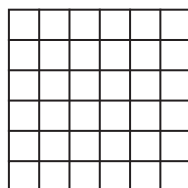

30x30 ☞ 6  
 MOS. QUADRETTI ECRU  
**UKR09101** rett. F 101,90

### OUTDOOR R11

9 mm

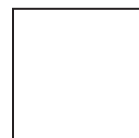

60x60 ☞ 3  
 UNIKA ECRU  
**UKN01600** bocc. nat. F 46,90  
**UKR01600** bocc. rett. F 53,90

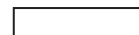

15x60 ☞ 12  
 UNIKA ECRU  
**UKR04600** bocc. rett. F 57,90



20x40 ☞ 15  
 UNIKA ECRU  
**UKN18100** bocc. nat. F 33,90



20x20 ☞ 30  
 UNIKA ECRU  
**UKN22100** bocc. nat. F 33,90

### OUT.20 R11

20 mm



40x80 ☞ 2  
 UNIKA ECRU  
**UKN51100** bocc. nat. F 91,90

Per la serie completa vedi pag. 290  
 For the complete collection see page 290

# Unika

BRONZE







60x120 ☞ 2  
UNIKA BRONZE  
**UKR3430A** rett. F 68,90  
**UKL3430A** ANTIQUE rett. F 81,90



30x120 ☞ 4  
UNIKA BRONZE  
**UKR57300** rett. F 68,90

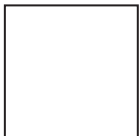

60x60 ☞ 3  
UNIKA BRONZE  
**UKN01300** nat. F 46,90  
**UKR01300** rett. F 53,90  
**UKL01300** ANTIQUE rett. F 64,90

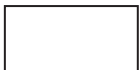

30x60 ☞ 6  
UNIKA BRONZE  
**UKR03300** rett. F 49,90



10x30 ☞ 18  
UNIKA BRONZE  
**UKR11300** rett. F 64,90

#### MIX FLOOR 60x120

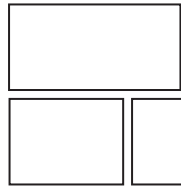

Pcs/Box:  
60x120 ☞ 1  
60x80 ☞ 1  
60x40 ☞ 1

60x120 ☞ 2  
UNIKA BRONZE MIX FLOOR  
**UKR3431A** rett. F 81,90

#### MIX WALL 60x80

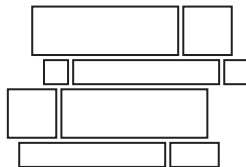

Pcs/Box:  
20x60 ☞ 4  
20x20 ☞ 4  
10x60 ☞ 4  
10x20 ☞ 2  
10x10 ☞ 4

60x80 ☞ 2  
UNIKA BRONZE MIX WALL  
**UKR20300** rett. F 74,90

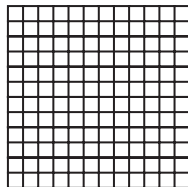

30x30 ☞ 4  
MOS. OPUS MINI BRONZE  
**UKR09302** F 252,90

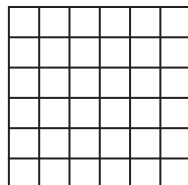



30x30 ☞ 6  
MOS. QUADRETTI BRONZE  
**UKR09301** rett. F 101,90

# Unika

GREY

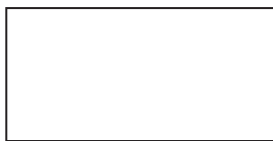





60x120  2  
 UNIKA GREY  
**UKR3415A** rett. F 68,90  
**UKL3415A** ANTIQUE rett. F 81,90

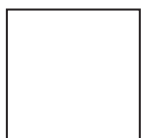

30x120  4  
 UNIKA GREY  
**UKR57150** rett. F 68,90



60x60  3  
 UNIKA GREY  
**UKN01150** nat. F 46,90  
**UKR01150** rett. F 53,90  
**UKL01150** ANTIQUE rett. F 64,90







30x60  6  
 UNIKA GREY  
**UKR03150** rett. F 49,90

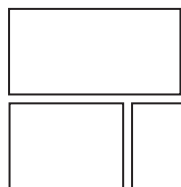

10x30  18  
 UNIKA GREY  
**UKR11150** rett. F 64,90

### MIX FLOOR 60x120





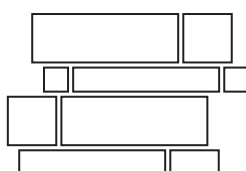

Pcs/Box:  
 60x120  1  
 60x80  1  
 60x40  1

60x120  2  
 UNIKA GREY MIX FLOOR  
**UKR3416A** rett. F 81,90

### MIX WALL 60x80



Pcs/Box:  
 20x60  4  
 20x20  4  
 10x60  4  
 10x20  2  
 10x10  4

60x80  2  
 UNIKA GREY MIX WALL  
**UKR20150** rett. F 74,90

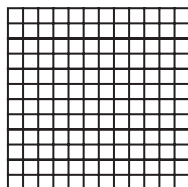

30x30  4  
 MOS. OPUS MINI GREY  
**UKR09152** F 252,90

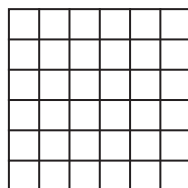

30x30  6  
 MOS. QUADRETTI GREY  
**UKR09151** rett. F 101,90

**OUTDOOR** **R11**  9 mm 



60x60  3  
 UNIKA GREY  
**UKN01650** bocc. nat. F 46,90  
**UKR01650** bocc. rett. F 53,90



15x60  12  
 UNIKA GREY  
**UKR04650** bocc. rett. F 57,90





20x40  15  
 UNIKA GREY  
**UKN18150** bocc. nat. F 33,90

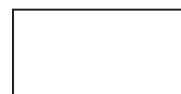

20x20  30  
 UNIKA GREY  
**UKN22150** bocc. nat. F 33,90

**OUT.20** **R11**  20 mm 



40x80  2  
 UNIKA GREY  
**UKN51150** bocc. nat. F 91,90

Per la serie completa vedi pag. 290  
 For the complete collection see page 290

# Unika

SMOKE









60x120  2  
 UNIKA SMOKE  
**UKR3420A** rett. F 68,90  
**UKL3420A** ANTIQUE rett. F 81,90

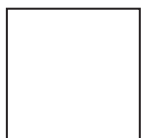

30x120  4  
 UNIKA SMOKE  
**UKR57200** rett. F 68,90



60x60  3  
 UNIKA SMOKE  
**UKN01200** nat. F 46,90  
**UKR01200** rett. F 53,90  
**UKL01200** ANTIQUE rett. F 64,90







30x60  6  
 UNIKA SMOKE  
**UKR03200** rett. F 49,90

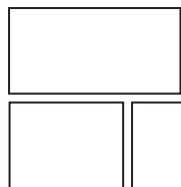

10x30  18  
 UNIKA SMOKE  
**UKR11200** rett. F 64,90

#### MIX FLOOR 60x120







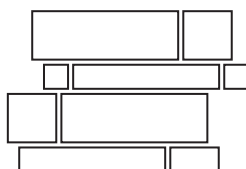

Pcs/Box:  
 60x120  1  
 60x80  1  
 60x40  1

60x120  2  
 UNIKA SMOKE MIX FLOOR  
**UKR3421A** rett. F 81,90

#### MIX WALL 60x80



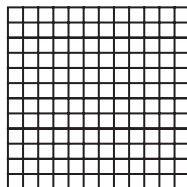

Pcs/Box:  
 20x60  4  
 20x20  4  
 10x60  4  
 10x20  2  
 10x10  4

60x80  2  
 UNIKA SMOKE MIX WALL  
**UKR20200** rett. F 74,90



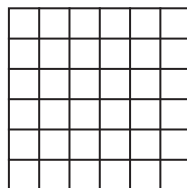

30x30  4  
 MOS. OPUS MINI SMOKE  
**UKR09202** F 252,90

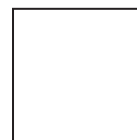

30x30  6  
 MOS. QUADRETTI SMOKE  
**UKR09201** rett. F 101,90

**OUTDOOR** **R11**  9 mm





60x60  3  
 UNIKA SMOKE  
**UKN01700** bocc. nat. F 46,90  
**UKR01700** bocc. rett. F 53,90

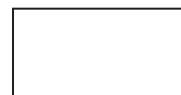

15x60  12  
 UNIKA SMOKE  
**UKR04700** bocc. rett. F 57,90

**OUT.20** **R11**  20 mm



40x80  2  
 UNIKA SMOKE  
**UKN51200** bocc. nat. F 91,90

Per la serie completa vedi pag. 290  
 For the complete collection see page 290

# Unika



60x60  3  
**UNIKA GAME ECRU**  
**UKR01400** rett. F 64,90  
 (UNIKA ECRU + DOLPHIN CLAY)

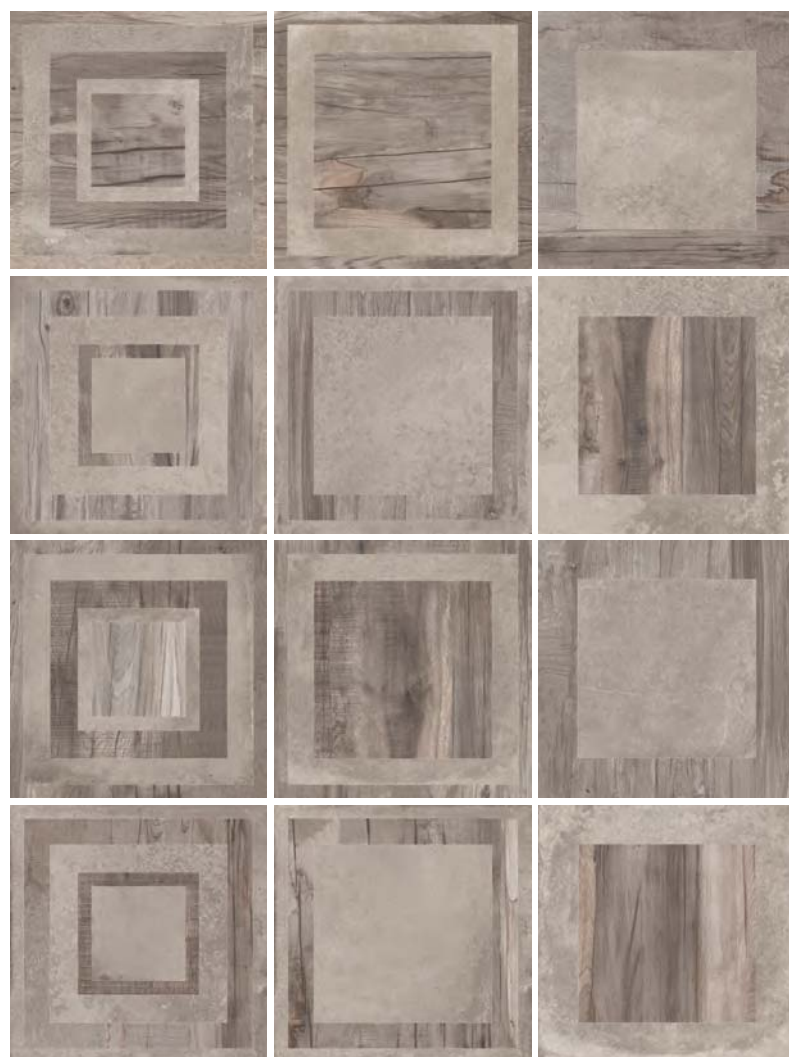

60x60  3  
**UNIKA GAME GREY**  
**UKR01450** rett. F 64,90  
 (UNIKA GREY + DOLPHIN GREY)

0,5x120  4  
**MATITA ALLUMINIO**  
**0000086** PZ 20,90

0,5x120  4  
**MATITA ALLUMINIO WHITE**  
**0000087** PZ 34,90

0,5x120  4  
**MATITA ALLUMINIO BLACK**  
**0000088** PZ 34,90

0,5x120  4  
**MATITA ALLUMINIO RAME**  
**0000556** PZ 34,90

0,5x120  4  
**MATITA ALLUMINIO BRONZO**  
**0000557** PZ 34,90



60x60  3  
**UNIKA GAME SMOKE**  
**UKR01500** rett. F 64,90  
 (UNIKA SMOKE + DOLPHIN COAL)



60x60  3  
**UNIKA FREEDOM**  
**UKR01350** rett. F 64,90



10x60  3  
**\*\* LISTONE WOM**  
**UKR01161** rett. PZ 34,90  
 (Metalli Preziosi - Precious metals)

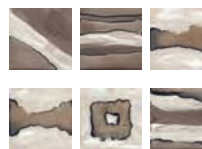

10x10  6  
**\*\* TOZZETTO WOM MIX 6**  
**UKR01162** rett. PZ 14,90  
 (Metalli Preziosi - Precious metals)



5x30  4  
**\* FASCIA ESSENZE MIX**  
**I9R03053** PZ 21,90  
 (Legno - Wood)



1,5x30  4  
**FASCIA VETRO PLATINO**  
**R1R03207** PZ 22,90



1,5x30  4  
**FASCIA VETRO BRONZO**  
**R1R03157** PZ 22,90



1,5x30  4  
**FASCIA VETRO ORO**  
**R1R03106** PZ 22,90

(Vetro e metalli preziosi - Glass and precious metals)



4x30  4  
**\* FASCIA ARDESIA BRONZO**  
**RER09054** PZ 20,90



4x30  4  
**\* FASCIA ARDESIA GRIGIO**  
**RER09204** PZ 20,90

(Pietra naturale - Natural stone)

\* Art. realizzati con materiali naturali: vedi indicazioni per posa e pulizia a pag. 393 dell' area tecnica.

\* Items produced with natural materials: check the technical area on page 393.

\*\* Metalli preziosi. Si consiglia di pulire la superficie senza utilizzare prodotti contenenti sostanze abrasive per non alterare la brillantezza del metallo prezioso.  
 Precious metal. Do not use products containing abrasive substances to clean the decorative element so as not to affect the shine of the precious metal.



# Unika

floor. Bronze rett. 60x60 - Bronze mix floor rett. 60x120 - 60x80 - 60x40





SCHEMI DI POSA  
INSTALLATION PATTERNS

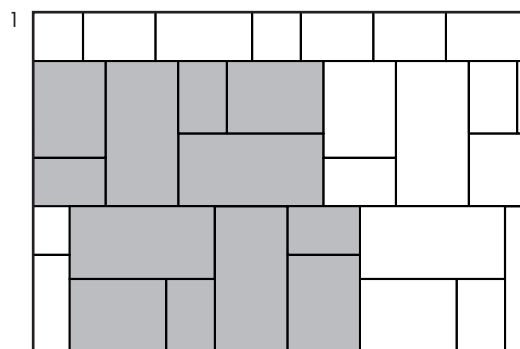

60x120 MIX FLOOR 100 %

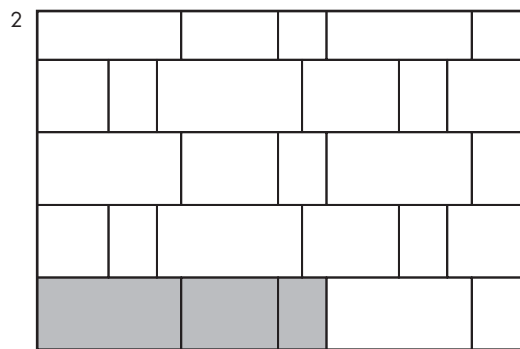

60x120 MIX FLOOR 100 %

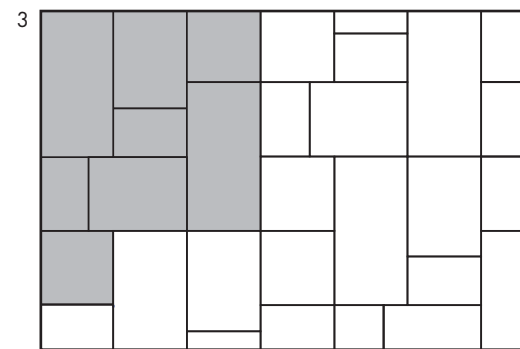

60x120 MIX FLOOR 80 %  
60x60 20 %

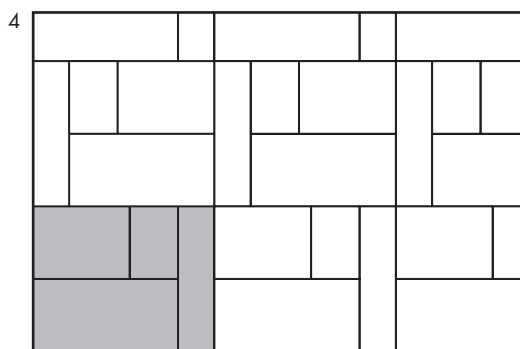

60x120 MIX FLOOR 80 %  
30x120 20 %

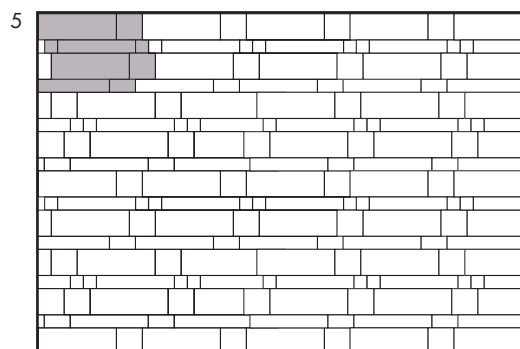

60x80 MIX WALL 100 %

PEZZI SPECIALI / SPECIAL TRIMS

		CREAM	ECRU	BRONZE	GREY	SMOKE
	BATTISCOPA rett. 5,5x60 PZ 7,90  10	UKR01052	UKR01102	UKR01302	UKR01152	UKR01202
	ELEMENTO L MONOL. 15x30x3,5 PZ 14,90  8	-	UKN18101 BOCCIARDATO	-	UKN18151 BOCCIARDATO	-
	GRADONE TOP rett. 32x120x4,5x2 PZ 172,90  1	UKR34052	UKR34102	UKR34302	UKR34152	UKR34202
	ANGOLARE TOP SX 32x120x4,5x2 PZ 198,90  1	UKR34054	UKR34104	UKR34304	UKR34154	UKR34204
	ANGOLARE TOP DX 32x120x4,5x2 PZ 198,90  1	UKR34055	UKR34105	UKR34305	UKR34155	UKR34205

# Unika W&P™

Per maggiori informazioni consulta l'area tecnica da pag. 374 - For more information check the technical area at page 374

▼  
9 mm  
▲



60x120  2  
UNIKA ILLUSION CREAM  
UKR3407A rett. F 81,90



60x120  2  
UNIKA ILLUSION GREY  
UKR3417A rett. F 81,90





60x120  2  
UNIKA ILLUSION SMOKE  
UKR3422A rett. F 81,90



## IMBALLI/PACKAGING

F.to nominale Nominal size	F.to reale (mm) Real size (mm)	Spessore Thickness	Pz/Scatola Pcs/Box	Mq/Scatola Sqm/Box	Kg/Scatola Kg/Box	Scatole/Imballo Box/Packing	Mq totali Sqm total	Kg totali Kg total
* 60x120 / 24"x48" rett.	596x1194	9 mm	2	1,44	27,20	26	37,44	748
* 60x120 mix floor	-	9 mm	2	1,44	27,20	26	37,44	748
* 30x120 / 12"x48" rett.	297x1194	9 mm	4	1,44	27,20	18	25,92	509
* 60x80 mix wall	-	9 mm	2	0,96	20,35	54	51,84	1119
60x60 / 24"x24" nat.	-	9 mm	3	1,08	21,20	40	43,20	868
60x60 / 24"x24" rett.	596x596	9 mm	3	1,08	21,20	40	43,20	868
30x60 / 12"x24" rett.	297x596	9 mm	6	1,08	21,20	40	43,20	868
15x60 / 6"x24" rett.	147,5x596	9 mm	12	1,08	21,20	40	43,20	868
10x30 / 4"x12" rett.	97,6x297	9 mm	18	0,54	11,60	64	34,56	763
* 60x120 W&P rett.	596x1194	9 mm	2	1,44	26,20	26	37,44	722
* 40x80 nat. 20 mm	-	20 mm	2	0,64	28,26	24	15,36	698
20x40 nat.	-	9 mm	15	1,20	21,00	64	76,80	1364
20x20 nat.	-	9 mm	30	1,20	21,00	64	76,80	1364

L'unità minima di vendita per tutti gli articoli (fondi, decori e pezzi speciali) è la scatola completa. / The minimum sales quantity for all items (plain tiles, decorations and special trims) is one full box.  
I dati relativi agli imballi sono aggiornati al momento della stampa del catalogo e pertanto possono subire variazioni nel corso del tempo. / Data referring to packaging have been update at time of printing; the actual data may be slightly different.  
Pezzi speciali e decori per effetto delle lavorazioni, possono presentare variazioni di tonalità. / Due to working process special trims and decors, may show variation in tonality.

	SIGILLANTI COORDINATI PER FUGHE / COORDINATED GROUT SEALANTS		COLLANTI / ADHESIVES		
	UNIKA	COLORE SIGILLANTE SEALANT COLOUR	CODICE SIGILLANTE SEALANT CODE		
	Unika Ecu		SI123B kromos manhattan		
	Unika Grey		SI150B kromos perla	*Vedi tabella imballi / *See at packaging list	
	Unika Bronze		SI121B kromos cemento		
	Unika Cream		SI120B kromos grigio luce	Bauflex Bianco AD200M	+30 Bianco AD330M
	Unika Smoke		SI152B kromos ardesia	Bauflex Grigio AD210M	+30 Grigio AD331M

Per una migliore resa estetica e tecnica ABK consiglia l'utilizzo di sigillanti e collanti HARDKOLL come da tabella. Per listino, scheda tecnica e approfondimenti vedi pag. 370  
ABK suggests Hardkoll sealants and adhesives for a better aesthetics and technical efficiency, as follow. Read more at page 370 for prices and technical data sheets.

# Re-work

## GRES PORCELLANATO A MASSA COLORATA

FULL BODY COLORED PORCELAIN STONEWARE

## SUPERFICI SURFACES

naturale - natural

patinato - honed

lines - structured

naturale R11 - natural R11

## FORMATI SIZES



80x80  
32"x 32"



40x80  
16"x 32"



20x80  
8"x 32"



60x60  
24"x 24"



30x60  
12"x 24"



10x30  
4"x 12"



20x40  
8"x 16"



20x20  
8"x 8"



40x80  
16"x 32"



Classificazione secondo norme UNI EN 14411 (ISO 13006) Allegato G Gruppo Bla  
Classification in accordance with UNI EN 14411 (ISO 13006) Annex G-Group Bla

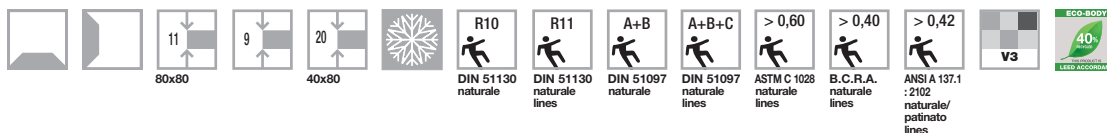







**MULTI FOG**

A color swatch with a mottled, multi-toned appearance in shades of grey and light blue-grey.

**MULTI BEIGE**

A color swatch with a mottled, multi-toned appearance in shades of beige and light tan.

**SINGLE 1 BONE**

A color swatch with a mottled, multi-toned appearance in shades of light beige and cream.

**SINGLE 1 WARM**

A color swatch with a mottled, multi-toned appearance in shades of warm beige and light brown.

**SINGLE 2 WHITE**

A color swatch with a mottled, multi-toned appearance in shades of off-white and light beige.

**SINGLE 2 GREY**

A color swatch with a mottled, multi-toned appearance in shades of grey and light blue-grey.

**SINGLE 3 SILVER**

A color swatch with a mottled, multi-toned appearance in shades of light grey and beige.

**SINGLE 3 BLACK**

A color swatch with a mottled, multi-toned appearance in shades of dark grey and black.



**Re-work** floor. Multi Beige rett. wall. 40x80 - 20x80 - Multi Lines Beige rett. 20x80 - Mosaico Opus Mini Beige 30x30



floor. Multi Fog rett. 40x80 wall. 20x80 - Multi Fog Lines rett. 20x80





# Re-work

MULTI FOG







40x80  3  
RE-WORK MULTI FOG  
**RER51400** rett. F 53,90



20x80  8  
RE-WORK MULTI FOG  
**RER4940B** rett. F 58,90



20x80  8  
RE-WORK MULTI LINES FOG  
**RER4950B** rett. F 58,90



60x60  3  
RE-WORK MULTI FOG  
**RER01400** rett. F 53,90  
**RELO1400** patinato rett. F 64,90

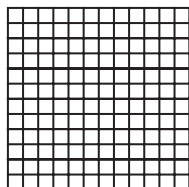

30x30  4  
MOS. OPUS MINI MULTI FOG  
**RER09403** rett. F 252,90



30x60  6  
RE-WORK MULTI FOG  
**REN03500** nat. F 38,90

**OUTDOOR** 

 9 mm  



20x40  15  
RE-WORK MULTI FOG  
**REN18400** nat. F 33,90



20x20  30  
RE-WORK MULTI FOG  
**REN22400** nat. F 33,90

**OUT.20** 

 20 mm  



40x80  2  
RE-WORK MULTI FOG 20  
**REN51400** nat. F 91,90

Per la serie completa vedi pag. 292  
For the complete collection see page 292



30x60  6  
MULTI FOG BRICK  
**REN03400** nat. F 40,90



30x60  2  
ANGOLARE MULTI FOG BRICK  
**REN03401** nat. PZ 32,90



80x80  1 cp  
COMP. SOUL FOG 4 pz.  
**RER49402** rett. PZ 199,90



4x30  4  
\* FASCIA ARDESIA GRIGIO  
**RE09204** rett. PZ 20,90  
(Pietra naturale - Natural stone)



1,5x30  4  
FASCIA VETRO PLATINO  
**R1R03207** PZ 22,90  
(Vetro e metalli preziosi - Glass and precious metals)



1,5x60  4  
MATITA METAL (alluminio - aluminium)  
**DWR01001** PZ 15,90



1,5x80  3  
MATITA METAL (alluminio - aluminium)  
**DKR51051** PZ 19,90



2x80  3  
LISTELLO FOGLIA ARGENTO (Vetro - Glass)  
**FSR51210** PZ 39,90

\* Art. realizzati con materiali naturali:  
vedi indicazioni per posa e pulizia a pag. 393 dell' area tecnica.  
\* Items produced with natural materials:  
check the technical area at page 393.

# Re-work

MULTI BEIGE

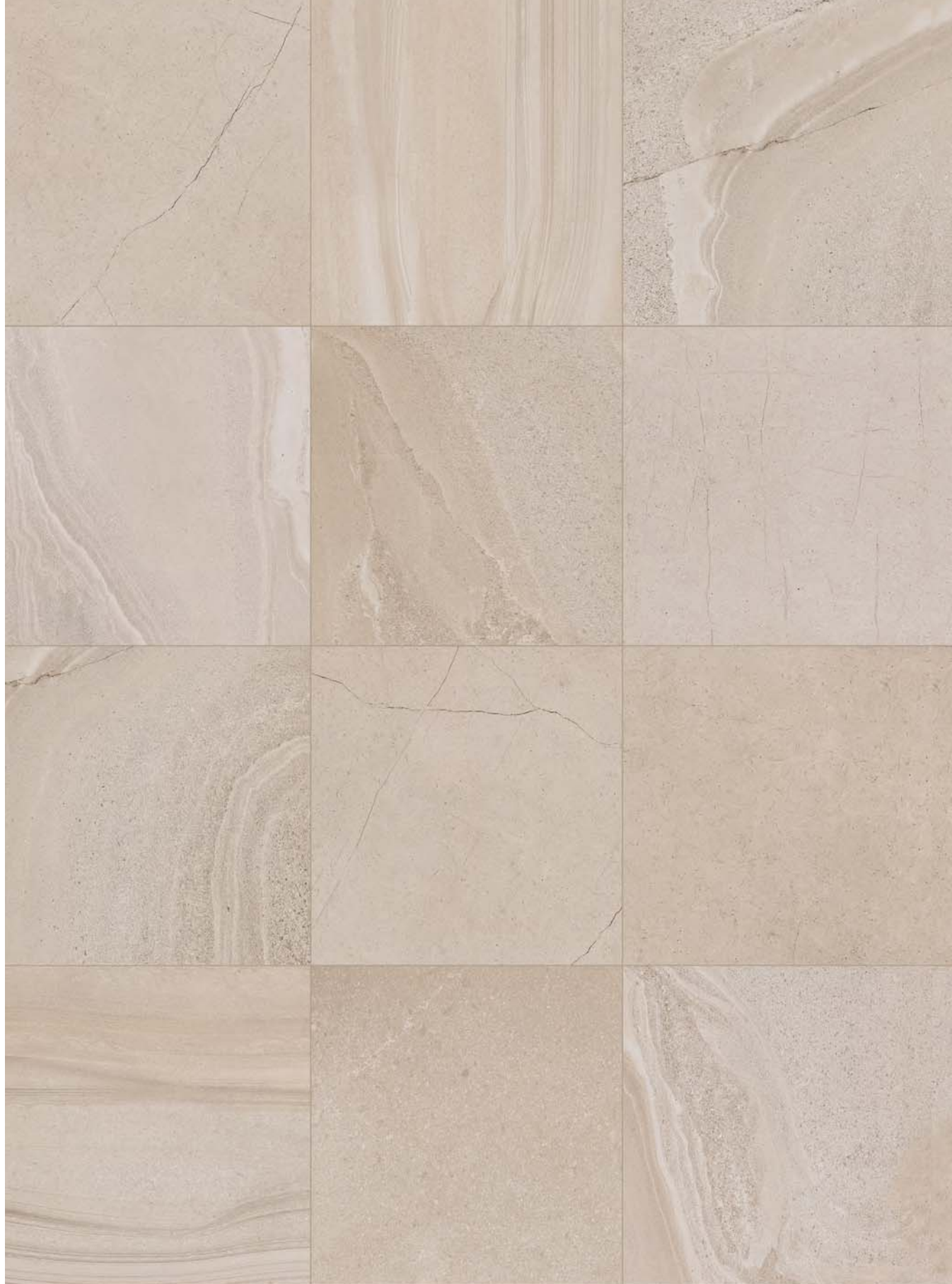



40x80  3  
RE-WORK MULTI BEIGE  
**RER51350** rett. F 53,90



20x80  8  
RE-WORK MULTI BEIGE  
**RER4935B** rett. F 58,90



20x80  8  
RE-WORK MULTI LINES BEIGE  
**RER4945B** rett. F 58,90



60x60  3  
RE-WORK MULTI BEIGE  
**RER01350** rett. F 53,90  
**RELO1350** patinato rett. F 64,90

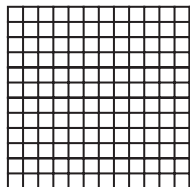

30x30  4  
MOS. OPUS MINI MULTI BEIGE  
**RER09353** rett. F 252,90



30x60  6  
RE-WORK MULTI BEIGE  
**REN03450** nat. F 38,90

**OUTDOOR** 

 9 mm  





20x40  15  
RE-WORK MULTI BEIGE  
**REN18350** nat. F 33,90



20x20  30  
RE-WORK MULTI BEIGE  
**REN22350** nat. F 33,90

**OUT.20** 

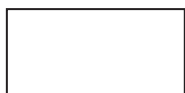
 20 mm  





40x80  2  
RE-WORK MULTI BEIGE 20  
**REN51350** nat. F 91,90



30x60  6  
MULTI BEIGE BRICK  
**REN03350** nat. F 40,90



30x60  2  
ANGOLARE MULTI BEIGE BRICK  
**REN03351** nat. PZ 32,90



80x80  1 cp  
COMP. SOUL BEIGE 4 pz.  
**RER49352** rett. PZ 199,90



4x30  4  
\* FASCIA ARDESIA BRONZO  
**REO9054** rett. PZ 20,90  
(Pietra naturale - Natural stone)



1,5x30  4  
FASCIA VETRO BRONZO  
**R1R03157** PZ 22,90  
(Vetro e metalli preziosi - Glass and precious metals)



1,5x60  4  
MATITA METAL (alluminio - aluminium)  
**DWR01001** PZ 15,90



1,5x80  3  
MATITA METAL (alluminio - aluminium)  
**DKR51051** PZ 19,90



2x80  3  
LISTELLO FOGLIA ORO (Vetro - Glass)  
**FSR51160** PZ 39,90

Per la serie completa vedi pag. 292  
For the complete collection see page 292

\* Art. realizzati con materiali naturali:  
vedi indicazioni per posa e pulizia a pag. 393 dell' area tecnica.  
\* Items produced with natural materials:  
check the technical area at page 393.



# Re-work

SINGLE 1 BONE







41,5x81  3  
RE-WORK SINGLE 1 BONE

**REN50050** nat. F 46,90

40x80  3  
RE-WORK SINGLE 1 BONE

**RER51050** rett. F 53,90

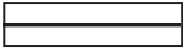

20x80  4  
RE-WORK LISTELLATO 3D SINGLE 1 BONE

**RER49051** rett. F 199,90

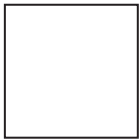

60x60  3  
RE-WORK SINGLE 1 BONE

**REN01050** nat. F 46,90

**RER01050** rett. F 53,90

**RELO1050** patinato rett. F 64,90



30x60  6  
RE-WORK SINGLE 1 BONE

**RER03050** rett. F 49,90



10x30  18  
RE-WORK SINGLE 1 BONE

**RER11050** rett. F 64,90

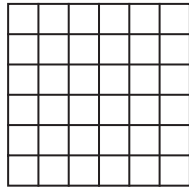

30x30  6  
MOS. QUAD. SINGLE 1 BONE

**RER09051** rett. F 101,90

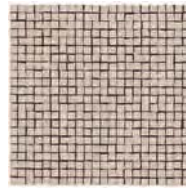

30x30  4  
MOS. OPUS MICRO SINGLE 1 BONE

**RER09052** rett. PZ 39,90



4x30  4  
\*FASCIA ARDESIA BRONZO

**RER09054** rett. PZ 20,90

(Pietra naturale - Natural stone)



1,5x30  4  
FASCIA VETRO BRONZO

**R1R03157** PZ 22,90

(Vetro e metalli preziosi - Glass and precious metals)



1,5x60  4  
MATITA METAL (alluminio - aluminium)

**DWR01001** PZ 15,90



1,5x80  3  
MATITA METAL (alluminio - aluminium)

**DKR51051** PZ 19,90



2x80  3  
LISTELLO FOGLIA ORO (Vetro - Glass)

**FSR51160** PZ 39,90



5x40  4  
\*LISTELLO WOOD

**DKR51055** rett. PZ 19,90

Antico legno alpino recuperato da costruzioni dismesse e trattato per l'utilizzo in parete e a pavimento.

Ogni pezzo è unico e irripetibile.

Antique alpin wood, recovered from discontinued buildings and treated for floor and wall use. Every single piece turns out to be different and unique.

\* Art. realizzati con materiali naturali:  
vedi indicazioni per posa e pulizia a pag. 393 dell' area tecnica.

\* Items produced with natural materials:  
check the technical area at page 393.

# Re-work

SINGLE 1 WARM



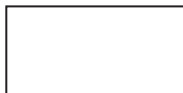

41,5x81  3  
RE-WORK SINGLE 1 WARM

**REN50100** nat. F 46,90

40x80  3  
RE-WORK SINGLE 1 WARM

**RER51100** rett. F 53,90



20x80  4  
RE-WORK LISTELLATO 3D SINGLE 1 WARM

**RER49101** rett. F 199,90



60x60  3  
RE-WORK SINGLE 1 WARM

**REN01100** nat. F 46,90

**RER01100** rett. F 53,90

**RELO1100** patinato rett. F 64,90



30x60  6  
RE-WORK SINGLE 1 WARM

**RER03100** rett. F 49,90



10x30  18  
RE-WORK SINGLE 1 WARM

**RER11100** rett. F 64,90

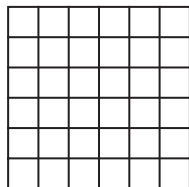

30x30  6  
MOS. QUAD. SINGLE 1 WARM

**RER09101** rett. F 101,90

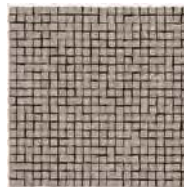

30x30  4  
MOS. OPUS MICRO SINGLE 1 WARM

**RER09102** rett. PZ 39,90



4x30  4  
\*FASCIA ARDESIA BRONZO

**RER09054** rett. PZ 20,90

(Pietra naturale - Natural stone)



1,5x30  4  
FASCIA VETRO BRONZO

**R1R03157** PZ 22,90

(Vetro e metalli preziosi - Glass and precious metals)



1,5x60  4  
MATITA METAL (alluminio - aluminium)

**DWR01001** PZ 15,90



1,5x80  3  
MATITA METAL (alluminio - aluminium)

**DKR51051** PZ 19,90



2x80  3  
LISTELLO FOGLIA ORO (Vetro - Glass)

**FSR51160** PZ 39,90



5x40  4  
\*LISTELLO WOOD

**DKR51055** rett. PZ 19,90

Antico legno alpino recuperato da costruzioni dismesse e trattato per l'utilizzo in parete e a pavimento.

Ogni pezzo è unico e irripetibile.

Antique alpin wood, recovered from discontinued buildings and treated for floor and wall use. Every single piece turns out to be different and unique.

\* Art. realizzati con materiali naturali:  
vedi indicazioni per posa e pulizia a pag. 393 dell' area tecnica.

\* Items produced with natural materials:  
check the technical area at page 393.

# Re-work

SINGLE 2 WHITE









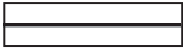

41,5x81  3  
RE-WORK SINGLE 2 WHITE  
**REN50150** nat. F 46,90

40x80  3  
RE-WORK SINGLE 2 WHITE  
**RER51150** rett. F 53,90

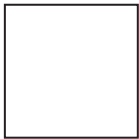

20x80  4  
RE-WORK LISTELLATO 3D SINGLE 2 WHITE  
**RER49151** rett. F 199,90



60x60  3  
RE-WORK SINGLE 2 WHITE  
**REN01150** nat. F 46,90  
**RER01150** rett. F 53,90  
**RELO1150** patinato rett. F 64,90



30x60  6  
RE-WORK SINGLE 2 WHITE  
**RER03150** rett. F 49,90



10x30  18  
RE-WORK SINGLE 2 WHITE  
**RER11150** rett. F 64,90

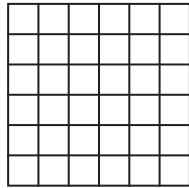

30x30  6  
MOS. QUAD. SINGLE 2 WHITE  
**RER09151** rett. F 101,90

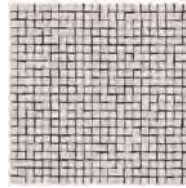

30x30  4  
MOS. OPUS MICRO SINGLE 2 WHITE  
**RER09152** rett. PZ 39,90



4x30  4  
\*FASCIA ARDESIA BRONZO  
**RER09054** rett. PZ 20,90  
(Pietra naturale - Natural stone)



1,5x30  4  
FASCIA VETRO BRONZO  
**R1R03157** PZ 22,90  
(Vetro e metalli preziosi - Glass and precious metals)



1,5x60  4  
MATITA METAL (alluminio - aluminium)  
**DWR01001** PZ 15,90



1,5x80  3  
MATITA METAL (alluminio - aluminium)  
**DKR51051** PZ 19,90



2x80  3  
LISTELLO FOGLIA ARGENTO (Vetro - Glass)  
**FSR51210** PZ 39,90



5x40  4  
\*LISTELLO WOOD  
**DKR51055** rett. PZ 19,90

Antico legno alpino recuperato da costruzioni dismesse e trattato per l'utilizzo in parete e a pavimento.

Ogni pezzo è unico e irripetibile.

Antique alpin wood, recovered from discontinued buildings and treated for floor and wall use. Every single piece turns out to be different and unique.

\* Art. realizzati con materiali naturali:  
vedi indicazioni per posa e pulizia a pag. 393 dell' area tecnica.

\* Items produced with natural materials:  
check the technical area at page 393.

# Re-work

SINGLE 2 GREY





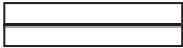

41,5x81  3  
RE-WORK SINGLE 2 GREY  
**REN50200** nat. F 46,90

40x80  3  
RE-WORK SINGLE 2 GREY  
**RER51200** rett. F 53,90

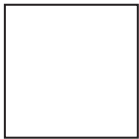

20x80  4  
RE-WORK LISTELLATO 3D SINGLE 2 GREY  
**RER49201** rett. F 199,90



60x60  3  
RE-WORK SINGLE 2 GREY  
**REN01200** nat. F 46,90  
**RER01200** rett. F 53,90  
**RELO1200** patinato rett. F 64,90



30x60  6  
RE-WORK SINGLE 2 GREY  
**RER03200** rett. F 49,90



10x30  18  
RE-WORK SINGLE 2 GREY  
**RER11200** rett. F 64,90

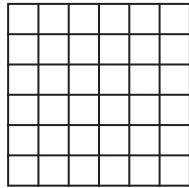

30x30  6  
MOS. QUAD. SINGLE 2 GREY  
**RER09201** rett. F 101,90

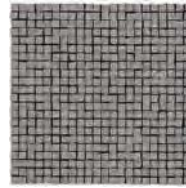

30x30  4  
MOS. OPUS MICRO SINGLE 2 GREY  
**RER09202** rett. PZ 39,90



4x30  4  
\* FASCIA ARDESIA GRIGIO  
**RER09204** rett. PZ 20,90  
(Pietra naturale - Natural stone)



1,5x30  4  
FASCIA VETRO PLATINO  
**R1R03207** PZ 22,90  
(Vetro e metalli preziosi - Glass and precious metals)



1,5x60  4  
MATITA METAL (alluminio - aluminium)  
**DWR01001** PZ 15,90



1,5x80  3  
MATITA METAL (alluminio - aluminium)  
**DKR51051** PZ 19,90



2x80  3  
LISTELLO FOGLIA ARGENTO (Vetro - Glass)  
**FSR51210** PZ 39,90



5x40  4  
\* LISTELLO WOOD  
**DKR51055** rett. PZ 19,90

Antico legno alpino recuperato da costruzioni dismesse e trattato per l'utilizzo in parete e a pavimento.

Ogni pezzo è unico e irripetibile.

Antique alpin wood, recovered from discontinued buildings and treated for floor and wall use. Every single piece turns out to be different and unique.

\* Art. realizzati con materiali naturali:  
vedi indicazioni per posa e pulizia a pag. 393 dell' area tecnica.

\* Items produced with natural materials:  
check the technical area at page 393.

# Re-work

SINGLE 3 SILVER

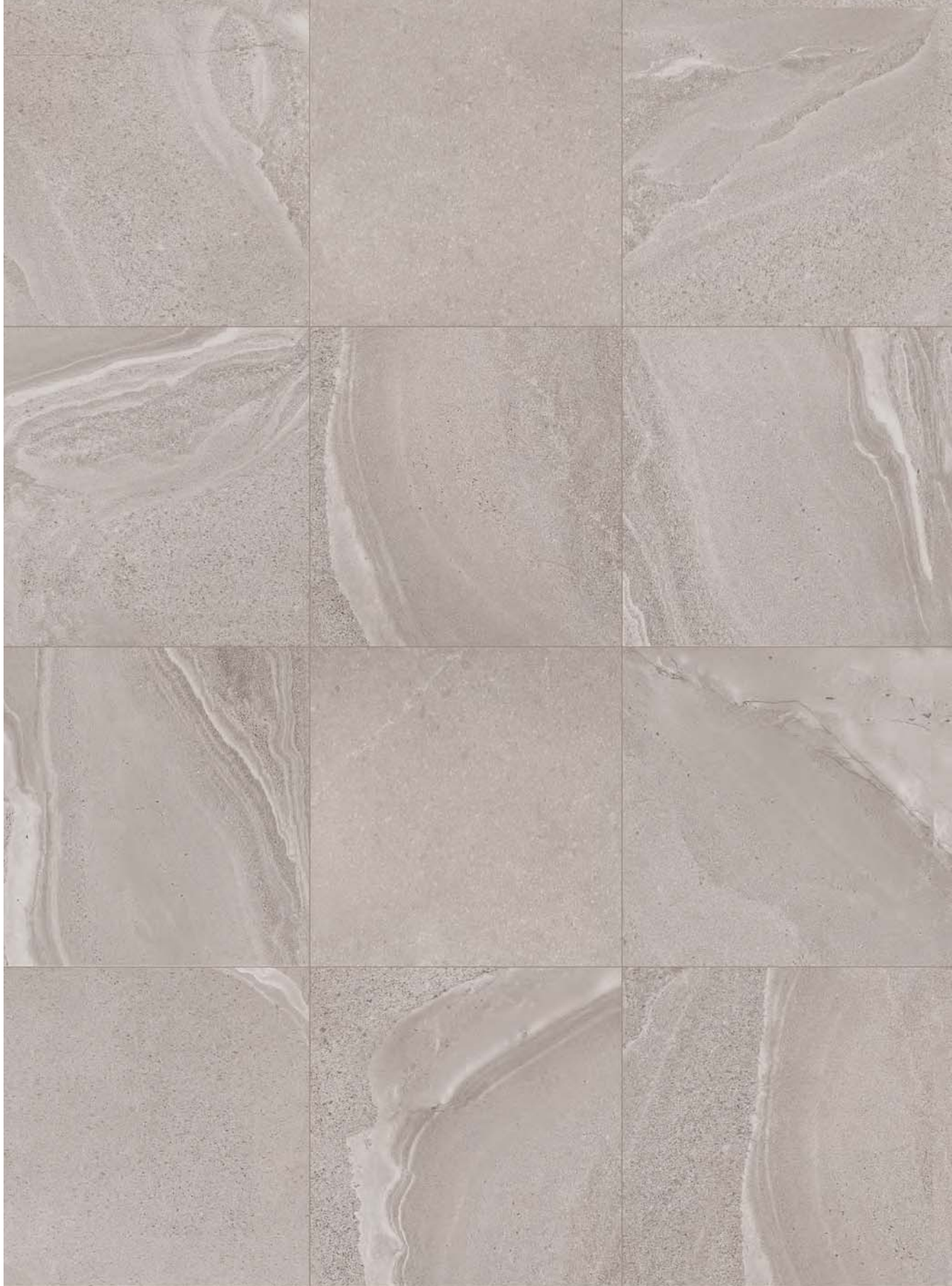



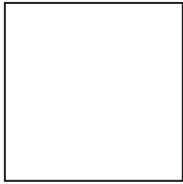





80x80  2  
RE-WORK SINGLE 3 SILVER  
**RER52250** rett. F 68,90



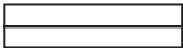

41,5x81  3  
RE-WORK SINGLE 3 SILVER  
**REN50250** nat. F 46,90

40x80  3  
RE-WORK SINGLE 3 SILVER  
**RER51250** rett. F 53,90

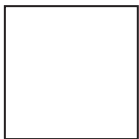

20x80  4  
RE-WORK LISTELLATO 3D SINGLE 3 SILVER  
**RER49251** rett. F 199,90



60x60  3  
RE-WORK SINGLE 3 SILVER  
**REN01250** nat. F 46,90  
**RER01250** rett. F 53,90  
**REL01250** patinato rett. F 64,90



30x60  6  
RE-WORK SINGLE 3 SILVER  
**RER03250** rett. F 49,90



10x30  18  
RE-WORK SINGLE 3 SILVER  
**RER11250** rett. F 64,90

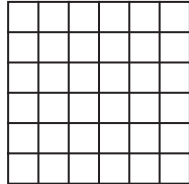

30x30  6  
MOS. QUAD. SINGLE 3 SILVER  
**RER09251** rett. F 101,90

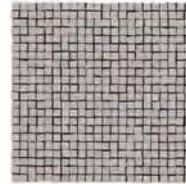

30x30  4  
MOS. OPUS MICRO SINGLE 3 SILVER  
**RER09252** rett. PZ 39,90



4x30  4  
\* FASCIA ARDESIA GRIGIO  
**RER09204** rett. PZ 20,90  
(Pietra naturale - Natural stone)



1,5x30  4  
FASCIA VETRO PLATINO  
**R1R03207** PZ 22,90  
(Vetro e metalli preziosi - Glass and precious metals)



1,5x60  4  
MATITA METAL (alluminio - aluminium)  
**DWR01001** PZ 15,90



1,5x80  3  
MATITA METAL (alluminio - aluminium)  
**DKR51051** PZ 19,90



2x80  3  
LISTELLO FOGLIA ARGENTO (Vetro - Glass)  
**FSR51210** PZ 39,90



5x40  4  
\* LISTELLO WOOD  
**DKR51055** rett. PZ 19,90

Antico legno alpino recuperato da costruzioni dismesse e trattato per l'utilizzo in parete e a pavimento.

Ogni pezzo è unico e irripetibile.  
Antique alpin wood, recovered from discontinued buildings and treated for floor and wall use.  
Every single piece turns out to be different and unique.

\* Art. realizzati con materiali naturali:  
vedi indicazioni per posa e pulizia a pag. 393 dell' area tecnica.  
\* Items produced with natural materials:  
check the technical area at page 393.

# Re-work

SINGLE 3 BLACK

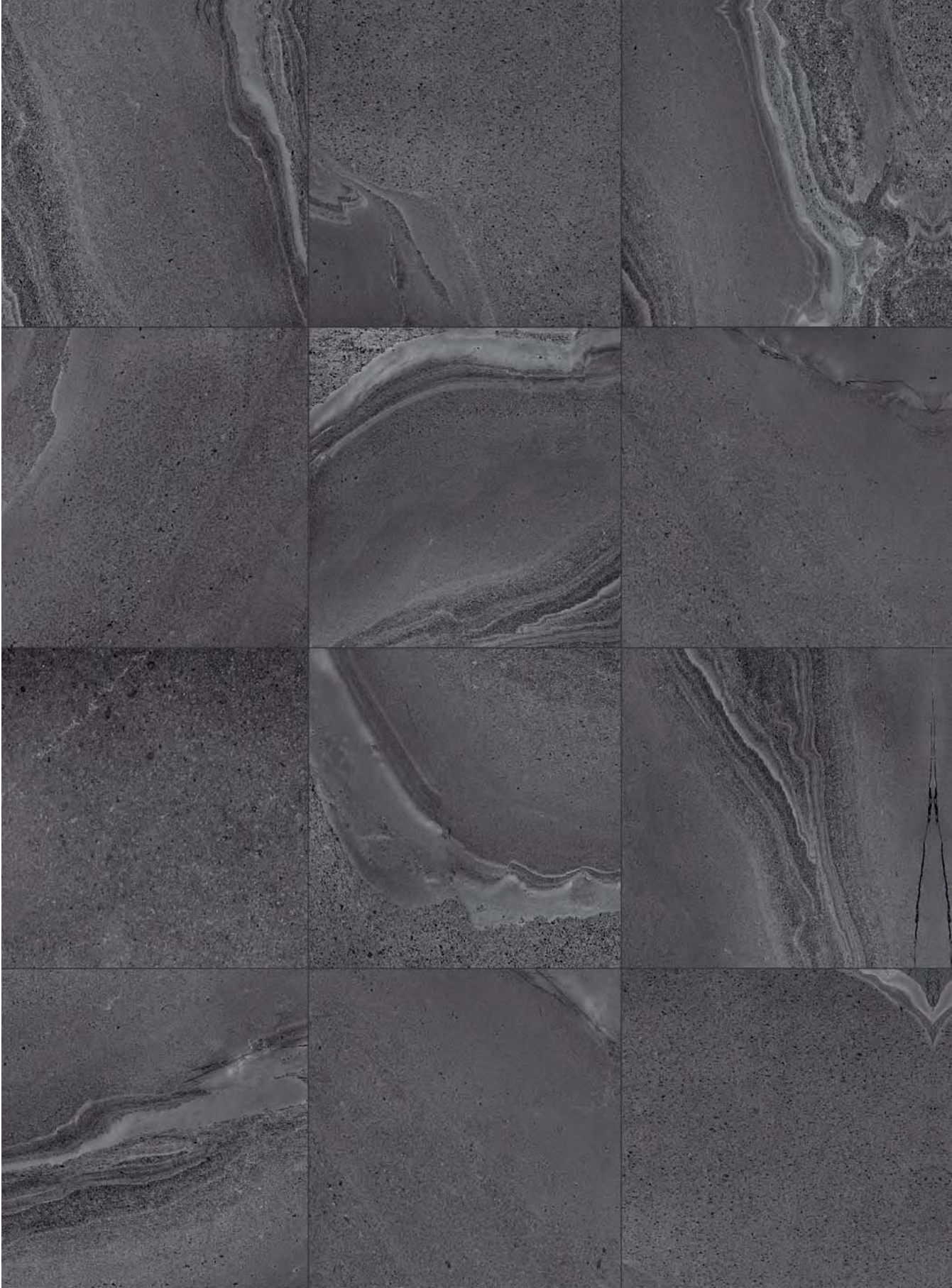

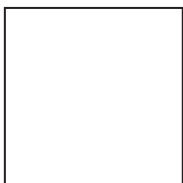

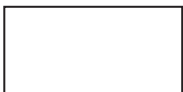

80x80  2  
RE-WORK SINGLE 3 BLACK  
**RER52300** rett. F 68,90



41,5x81  3  
RE-WORK SINGLE 3 BLACK  
**REN50300** nat. F 46,90

40x80  3  
RE-WORK SINGLE 3 BLACK  
**RER51300** rett. F 53,90



20x80  4  
RE-WORK LISTELLATO 3D SINGLE 3 BLACK  
**RER49301** rett. F 199,90



60x60  3  
RE-WORK SINGLE 3 BLACK  
**REN01300** nat. F 46,90  
**RER01300** rett. F 53,90  
**RELO1300** patinato rett. F 64,90



30x60  6  
RE-WORK SINGLE 3 BLACK  
**RER03300** rett. F 49,90



10x30  18  
RE-WORK SINGLE 3 BLACK  
**RER11300** rett. F 64,90

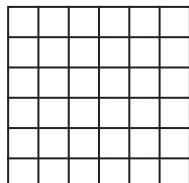

30x30  6  
MOS. QUAD. SINGLE 3 BLACK  
**RER09301** rett. F 101,90

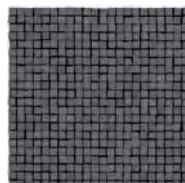

30x30  4  
MOS. OPUS MICRO SINGLE 3 BLACK  
**RER09302** rett. PZ 39,90



4x30  4  
\* FASCIA ARDESIA GRIGIO  
**RER09204** rett. PZ 20,90  
(Pietra naturale - Natural stone)



1,5x30  4  
FASCIA VETRO PLATINO  
**R1R03207** PZ 22,90  
(Vetro e metalli preziosi - Glass and precious metals)



1,5x60  4  
MATITA METAL (alluminio - aluminium)  
**DWR01001** PZ 15,90

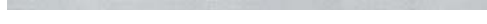

1,5x80  3  
MATITA METAL (alluminio - aluminium)  
**DKR51051** PZ 19,90



2x80  3  
LISTELLO FOGLIA ARGENTO (Vetro - Glass)  
**FSR51210** PZ 39,90



5x40  4  
\* LISTELLO WOOD  
**DKR51055** rett. PZ 19,90

Antico legno alpino recuperato da costruzioni dismesse e trattato per l'utilizzo in parete e a pavimento.

Ogni pezzo è unico e irripetibile.  
Antique alpin wood, recovered from discontinued buildings and treated for floor and wall use.  
Every single piece turns out to be different and unique.

\* Art. realizzati con materiali naturali:  
vedi indicazioni per posa e pulizia a pag. 393 dell' area tecnica.  
\* Items produced with natural materials:  
check the technical area at page 393.













# Re-work

floor. ASingle 1 Bone rett. 60x60 - Grad. Top 33x60x4,5x2



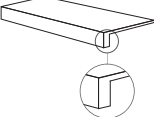

## PEZZI SPECIALI / SPECIAL TRIMS

		MULTI FOG	MULTI BEIGE	SINGLE 1 BONE	SINGLE 1 WARM	SINGLE 2 WHITE	SINGLE 2 GREY	SINGLE 3 SILVER	SINGLE 3 BLACK
	BATTISCOPA rett. 6,5x80 PZ 8,90  8	-	-	RER52051	RER52101	RER52151	RER52201	RER52251	RER52301
	BATTISCOPA rett. 6,5x60 PZ 7,90  10	RER01401	RER01351	RER01051	RER01101	RER01151	RER01201	RER01251	RER01301
	ELEMENTO L MONOL. 15x30x3,5 PZ 14,90  8	REN18401 R11	REN18351 R11	-	-	-	-	-	-
	GRADONE TOP rett. 33x60x4,5x2 PZ 79,90  2	RER03404	RER03354	RER03054	RER03104	RER03154	RER03204	RER03254	RER03304
	ANGOLARE TOP SX 33x60x4,5x2 PZ 108,90  1	RER03406	RER03356	RER03056	RER03106	RER03156	RER03206	RER03256	RER03306
	ANGOLARE TOP DX 33x60x4,5x2 PZ 108,90  1	RER03405	RER03355	RER03055	RER03105	RER03155	RER03205	RER03255	RER03305

## IMBALLI/PACKAGING



F.to nominale Nominal size	F.to reale (mm) Real size (mm)	Spessore Thickness	Pz/Scatola Pcs/Box	Mq/Scatola Sqm/Box	Kg/Scatola Kg/Box	Scatole/Imballo Box/Packing	Mq totali Sqm total	Kg totali Kg total
* 80x80 / 32"x32" rett.	800x800	11 mm	2	1,28	32,50	40	51,20	1320
* 41,5x81 / 16.6"x32.4" nat.	-	9 mm	3	1,01	19,50	30	30,30	605
* 40x80 / 16"x32" nat. 20 mm	-	20 mm	2	0,64	28,26	24	15,36	698
* 40x80 / 16"x32" rett.	400x800	9 mm	3	0,96	19,50	30	28,80	605
* 20x80 / 8"x32" rett.	199x800	9 mm	8	1,28	24,00	42	53,76	1028
60x60 / 24"x24" nat./rett.	596x596	9 mm	3	1,08	21,20	40	43,20	868
30x60 / 12"x24" rett.	297x596	9 mm	6	1,08	21,20	40	43,20	868
30x60 / 12"x24" nat.	-	9 mm	6	1,08	20,50	40	43,20	840
10x30 / 4"x12" rett.	97,6x297	9 mm	18	0,54	11,60	64	34,56	763
20x40 / 8"x16" nat.	-	9 mm	15	1,20	21,00	64	76,80	1364
20x20 / 8"x8" nat.	-	9 mm	30	1,20	21,00	64	76,80	1364

L'unità minima di vendita per tutti gli articoli (fondi, decori e pezzi speciali) è la scatola completa. / The minimum sales quantity for all items (plain tiles, decorations and special trims) is one full box.

I dati relativi agli imballi sono aggiornati al momento della stampa del catalogo e pertanto possono subire variazioni nel corso del tempo. / Data referring to packaging have been update at time of printing; the actual data may be slightly different.

Pezzi speciali e decori per effetto delle lavorazioni, possono presentare variazioni di tonalità. / Due to working process special trims and decors, may show variation in tonality.

Pezzi speciali e decori per effetto delle lavorazioni, possono presentare variazioni di tonalità. / Due to working process special trims and decors, may show variation in tonality.

RE-WORK	SIGILLANTI COORDINATI PER FUGHE / COORDINATED GROUT SEALANTS		COLLANTI / ADHESIVES	
	COLORE SIGILLANTE SEALANT COLOUR	CODICE SIGILLANTE SEALANT CODE		
Multi fog - Single 3 silver		SI150B kromos perla		
Multi beige - Single 1 bone		SI153B kromos tortora		
Single 1 warm		SI121B kromos cemento		
Single 2 white		SI120B kromos grigio luce		
Single 2 grey		SI152B kromos ardesia		
Single 3 black		SI122B kromos antracite		
			*Vedi tabella imballi / *See at packaging list	
			Bauflex Bianco AD200M	Baulite S2 Bianco AD340M
			Bauflex Grigio AD210M	Baulite S2 Grigio AD341M

Per una migliore resa estetica e tecnica ABK consiglia l'utilizzo di sigillanti e collanti HARDKOLL come da tabella. Per listino, scheda tecnica e approfondimenti vedi pag. 370  
ABK suggests Hardkoll sealants and adhesives for a better aesthetics and technical efficiency, as follow. Read more at page 370 for prices and technical data sheets.

## GRES PORCELLANATO PORCELAIN STONEWARE

### SUPERFICI SURFACES

naturale - natural  
lappato - honed

### FORMATI SIZES

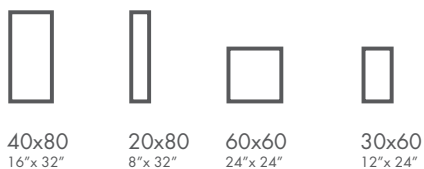

▼  
9 mm  
▲

---

Classificazione secondo norme UNI EN 14411 (ISO 13006) Allegato G Gruppo Bla GL  
Classification in accordance with UNI EN 14411 (ISO 13006) Annex G-Group Bla GL



A horizontal rectangular swatch of a light cream or off-white color with a subtle, organic texture and slight variations in tone.

**CREAM**

A horizontal rectangular swatch of a beige color with a mottled, textured appearance, showing some darker brownish undertones.

**BEIGE**

A horizontal rectangular swatch of a brown color with a complex, layered texture, featuring darker brown and reddish-brown accents.

**BROWN**

A horizontal rectangular swatch of a blue color with a textured, slightly grainy appearance, showing some darker and lighter variations.

**BLUE**

A horizontal rectangular swatch of a light grey color with a soft, textured appearance, showing some subtle variations in tone.

**LIGHT GREY**



# Fossil

floor. Deluxe brown 20x80 lapp. rett.





wall. Stone beige 30x60 - fascia ars hot 5x33,3



# Fossil

## BEIGE



### DELUXE



40x80  3

FOSSIL BEIGE

**FSR5110C** rett. F 58,90

**FSL5110C** lappato rett. F 67,90



20x80  8

FOSSIL BEIGE

**FSR4910B** rett. F 67,90

**FSL4910B** lappato rett. F 76,90

1,5x80  3

MATITA METAL (alluminio - aluminium)

**DKR51051** PZ 19,90

2x80  3

LISTELLO FOGLIA ARGENTO (Vetro - Glass)

**FSR51210** PZ 39,90

2x80  3

LISTELLO FOGLIA ORO (Vetro - Glass)

**FSR51160** PZ 39,90

## BROWN



### DELUXE

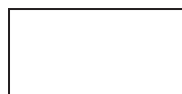

40x80  3

FOSSIL BROWN

**FSR5115C** rett. F 58,90

**FSL5115C** lappato rett. F 67,90



20x80  8

FOSSIL BROWN

**FSR4915B** rett. F 67,90

**FSL4915B** lappato rett. F 76,90

1,5x30  4

FASCIA VETRO ORO

**R1R03106** PZ 22,90

1,5x30  4

FASCIA VETRO BRONZO

**R1R03157** PZ 22,90

1,5x30  4

FASCIA VETRO PLATINO

**R1R03207** PZ 22,90

(Vetro e metalli preziosi - Glass and precious metals)



## BLUE



### DELUXE



40x80  3  
FOSSIL BLUE

<b>FSR5125C</b>	rett.	F 58,90
<b>FSL5125C</b>	lappato rett.	F 67,90

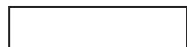

20x80  8  
FOSSIL BLUE

<b>FSR4925B</b>	rett.	F 67,90
<b>FSL4925B</b>	lappato rett.	F 76,90

5x40  4  
\* LISTELLO WOOD

<b>DKR51055</b>	rett.	PZ 19,90
-----------------	-------	----------

Antico legno alpino recuperato da costruzioni dismesse e trattato per l'utilizzo in parete e a pavimento.

Ogni pezzo è unico e irripetibile.

Antique alpin wood, recovered from discontinued buildings and treated for floor and wall use.

Every single piece turns out to be different and unique.

\* Art. realizzati con materiali naturali:  
vedi indicazioni per posa e pulizia a pag. 393 dell' area tecnica.  
Items produced with natural materials:  
check the technical area at page 393.

## LIGHT GREY



### DELUXE



40x80  3  
FOSSIL LIGHT GREY

<b>FSR5120C</b>	rett.	F 58,90
<b>FSL5120C</b>	lappato rett.	F 67,90



20x80  8  
FOSSIL LIGHT GREY

<b>FSR4920B</b>	rett.	F 67,90
<b>FSL4920B</b>	lappato rett.	F 76,90

# Fossil

CREAM



STONE



30x60  6  
FOSSIL CREAM

**FSN03050** F 38,90



50x50  4  
FOSSIL CREAM

**FSN24050** F 38,90



30x30  6  
MOS. QUADRETTI FOSSIL CREAM

**FSN03060** F 101,90



30x30  6  
MOS. QUADRETTI FOSSIL MIX CRE/BE/BR.

**FSN03061** F 101,90



30x30  6  
MOS. MURETTO FOSSIL CREAM

**FSN03065** F 106,90

BEIGE

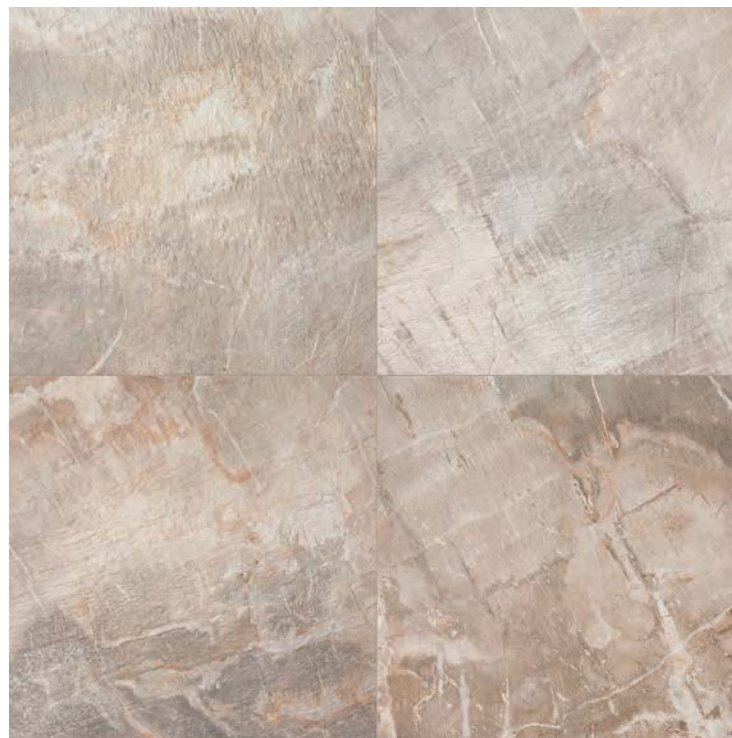

STONE



30x60  6  
FOSSIL BEIGE

**FSN03100** F 38,90



50x50  4  
FOSSIL BEIGE

**FSN24100** F 38,90



30x30  6  
MOS. QUADRETTI FOSSIL BEIGE

**FSN03110** F 101,90



30x30  6  
MOS. QUADRETTI FOSSIL MIX CRE/BE/BR.

**FSN03061** F 101,90



30x30  6  
MOS. MURETTO FOSSIL BEIGE

**FSN03115** F 106,90



# Fossil

BROWN

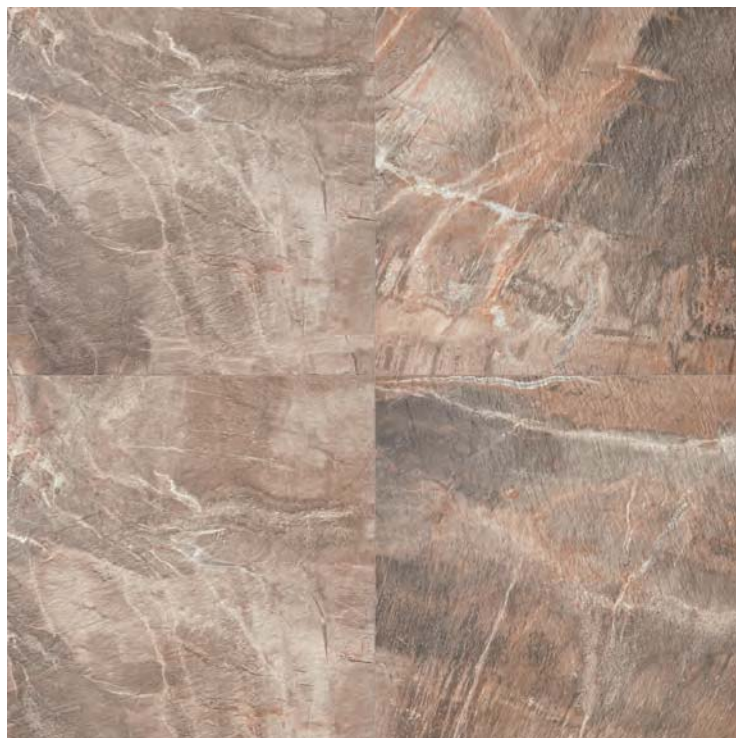

## STONE



30x60  6  
FOSSIL BROWN  
**FSN03150** F 38,90



50x50  4  
FOSSIL BROWN  
**FSN24150** F 38,90



30x30  6  
MOS. QUADRETTI FOSSIL BROWN  
**FSN03160** F 101,90



30x30  6  
MOS. QUADRETTI FOSSIL MIX CRE/BE/BR.  
**FSN03061** F 101,90



30x30  6  
MOS. MURETTO FOSSIL BROWN  
**FSN03165** F 106,90

COORDINATI DA RIVESTIMENTO / WALL COORDINATED DECORS



30x60  6  
BLEND FOSSIL MIX CREAM  
**FSN03500** F 40,90



30x60  2  
ANGOLARE BLEND FOSSIL MIX CREAM  
**FSN03501** PZ 32,90



5x33,3  4  
FASCIA ARS HOT  
**FSN03064** PZ 33,90

(Marmo e metalli preziosi - Marble and precious metals)



1,5x30  4  
FASCIA VETRO ORO  
**R1R03106** PZ 22,90



1,5x30  4  
FASCIA VETRO BRONZO  
**R1R03157** PZ 22,90

(Vetro e metalli preziosi - Glass and precious metals)



30x30  4  
MOS. MINI FOSSIL MIX CRE/BE/BR.  
**FSN03066** PZ 26,90

# Fossil

BLUE

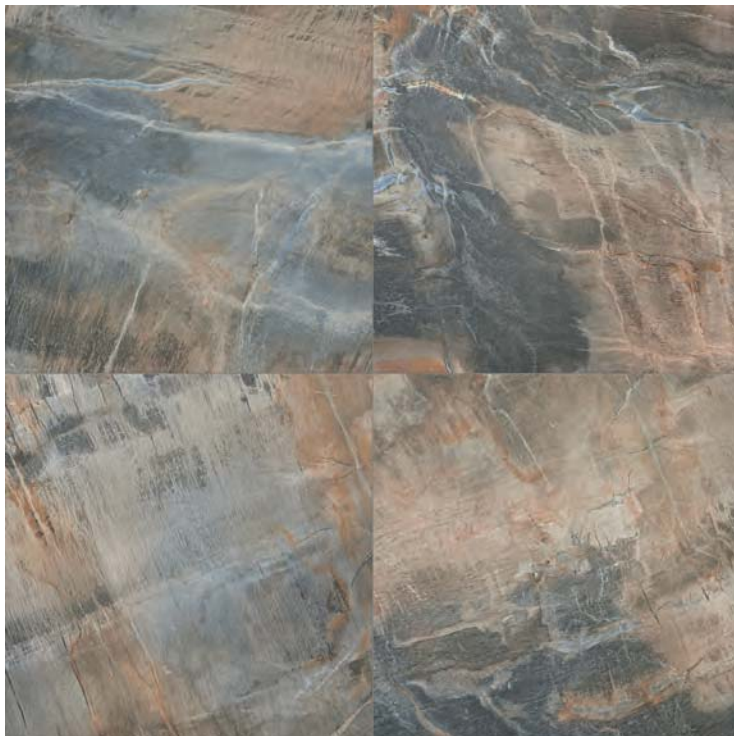

STONE



30x60  6  
FOSSIL BLUE  
FSN03250

F 38,90



50x50  4  
FOSSIL BLUE  
FSN24250

F 38,90



30x30  6  
MOS. QUADRETTI FOSSIL BLUE  
FSN03260

F 101,90



30x30  6  
MOS. QUADRETTI FOSSIL MIX L. GREY/BLUE  
FSN03211

F 101,90



30x30  6  
MOS. MURETTO FOSSIL BLUE  
FSN03265

F 106,90

LIGHT GREY



STONE



30x60  6  
FOSSIL LIGHT GREY  
FSN03200

F 38,90



50x50  4  
FOSSIL LIGHT GREY  
FSN24200

F 38,90



30x30  6  
MOS. QUADRETTI FOSSIL LIGHT GREY  
FSN03210

F 101,90



30x30  6  
MOS. QUADRETTI FOSSIL MIX L. GREY/BLUE  
FSN03211

F 101,90



30x30  6  
MOS. MURETTO FOSSIL LIGHT GREY  
FSN03215

F 106,90



5x33,3  4  
FASCIA ARS COLD  
FSN03214

PZ 33,90

236

(Marmo e metalli preziosi - Marble and precious metals)

# Fossil

COORDINATI DA RIVESTIMENTO / WALL COORDINATED DECORS



30x60 6  
BLEND FOSSIL MIX GREY  
**FSN03550** F 40,90



30x60 2  
ANGOLARE BLEND FOSSIL MIX GREY  
**FSN03551** PZ 32,90



30x30 4  
MOS. MINI FOSSIL MIX LIGHT GREY/BLUE  
**FSN03216** PZ 26,90

1,5x30 4

FASCIA VETRO PLATINO  
**R1R03207** PZ 22,90

1,5x30 4

FASCIA VETRO BRONZO  
**R1R03157** PZ 22,90  
(Vetro e metalli preziosi - Glass and precious metals)

## PEZZI SPECIALI / SPECIAL TRIMS

		CREAM	BEIGE	BROWN	BLUE	LIGHT GREY
	BATTISCOPA rett. 6,5x80 PZ 8,90  8	-	<b>FSR51101</b>	<b>FSR51151</b>	<b>FSR51251</b>	<b>FSR51201</b>
	BATTISCOPA 8x50 PZ 5,90  12	<b>FSN24051</b>	<b>FSN24101</b>	<b>FSN24151</b>	<b>FSN24251</b>	<b>FSN24201</b>
	GRADINO L rett. 33x40x4 PZ 41,90  1	-	<b>FSR51105</b>	<b>FSR51155</b>	<b>FSR51255</b>	<b>FSR51205</b>

## IMBALLI/PACKAGING

F.to nominale Nominal size	F.to reale (mm) Real size (mm)	Spessore Thickness	Pz/Scatola Pcs/Box	Mq/Scatola Sqm/Box	Kg/Scatola Kg/Box	Scatole/Imballo Box/Packing	Mq totali Sqm total	Kg totali Kg total
* 40x80 / 16"x32" rett.	400x800	9 mm	3	0,96	19,50	30	28,80	605
* 20x80 / 8"x32" rett.	199x800	9 mm	8	1,28	24,00	42	53,76	1028
30x60 / 12"x24" nat.	-	9 mm	6	1,08	20,50	40	43,20	840
50x50 / 20"x20" nat.	-	9 mm	4	1,00	20,00	36	36,00	740

L'unità minima di vendita per tutti gli articoli (fondi, decori e pezzi speciali) è la scatola completa. / The minimum sales quantity for all items (plain tiles, decorations and special trims) is one full box.  
I dati relativi agli imballi sono aggiornati al momento della stampa del catalogo e pertanto possono subire variazioni nel corso del tempo. / Data referring to packaging have been update at time of printing; the actual data may be slightly different.  
Pezzi speciali e decori per effetto delle lavorazioni, possono presentare variazioni di tonalità. / Due to working process special trims and decors, may show variation in tonality.

## SIGILLANTI COORDINATI PER FUGHE / COORDINATED GROUT SEALANTS

FOSSIL	COLORE SIGILLANTE SEALANT COLOUR	CODICE SIGILLANTE SEALANT CODE
Fossil Brown - Blue		SI123B kromos manhattan
Fossil Beige		SI153B kromos tortora
Light grey		SI120B kromos grigio luce
Fossil Cream		SI126B kromos avorio

## COLLANTI / ADHESIVES

* Vedi tabella imballi / * See at packaging list	
Bauflex Bianco AD200M	Baulite S2 Bianco AD340M
Bauflex Grigio AD210M	Baulite S2 Grigio AD341M

Per una migliore resa estetica e tecnica ABK consiglia l'utilizzo di sigillanti e collanti HARDKOLL come da tabella. Per listino, scheda tecnica e approfondimenti vedi pag. 370  
ABK suggests Hardkoll sealants and adhesives for a better aesthetics and technical efficiency, as follow. Read more at page 370 for prices and technical data sheets.

# Dolphin

**AUTO-LEVELING™**

Facile installazione - Easy laying

## GRES PORCELLANATO A MASSA COLORATA

FULL BODY COLORED PORCELAIN STONEWARE

## SUPERFICI SURFACES

naturale - natural

aged R11 - structured R11

## FORMATI SIZES

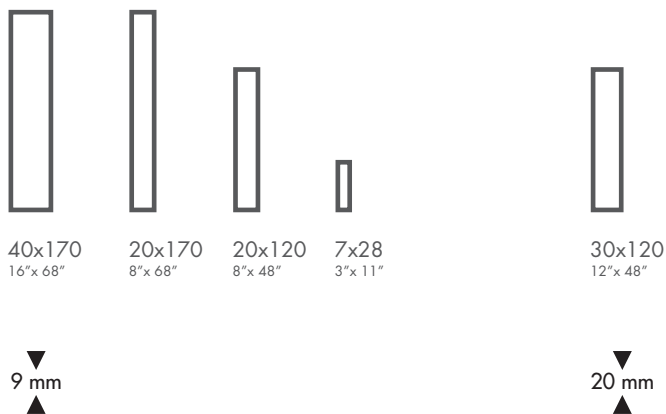

Classificazione secondo norme UNI EN 14411 (ISO 13006) Allegato G Gruppo B1a  
Classification in accordance with UNI EN 14411 (ISO 13006) Annex G-Group B1a

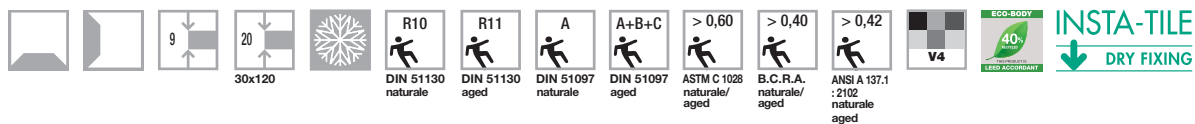



A horizontal strip of wood with a light, pale cream color and subtle, natural grain patterns.

**MILK**

A horizontal strip of wood with a medium brown tone and a slightly more pronounced grain.

**CLAY**

A horizontal strip of wood with a dark brown, rich tone and a very prominent, wavy grain pattern.

**OAK**

A horizontal strip of wood with a light greyish-tan color and a fine, uniform grain texture.

**MOON**

A horizontal strip of wood with a medium grey tone and a grain pattern similar to the 'MOON' swatch but with slightly more variation.

**GREY**

A horizontal strip of wood with a very dark, charcoal grey color and a grain pattern similar to the 'OAK' swatch.

**COAL**



# Dolphin

wall. Grey rett. 20x170, Coal rett. 20x170, Clay rett. 20x170, Oak rett. 20x170 floor. Coal rett. 40x170





outdoor. dolphin oak aged 20x120 - grey aged 20x120 indoor. oak 20x120





# Dolphin

MILK



40x170  2  
DOLPHIN MILK  
**DPR5605A** rett. F 91,90



20x170  4  
DOLPHIN MILK  
**DPR5505A** rett. F 91,90



20x120  6  
DOLPHIN MILK  
**DPR35050** rett. F 68,90

**OUTDOOR** 

 9 mm  



20x120  6  
DOLPHIN MILK  
**DPR35500** aged rett. F 68,90

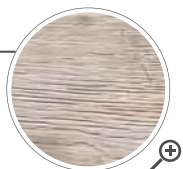





# Dolphin

CLAY

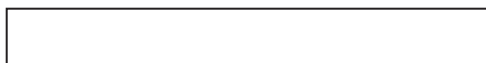

40x170  2  
DOLPHIN CLAY  
**DPR5610A** rett. F 91,90



20x170  4  
DOLPHIN CLAY  
**DPR5510A** rett. F 91,90



20x120  6  
DOLPHIN CLAY  
**DPR35100** rett. F 68,90

**OUTDOOR** 

▼  
9 mm  
▲

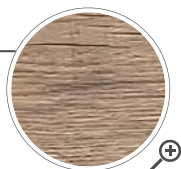

20x120  6  
DOLPHIN CLAY  
**DPR35650** aged rett. F 68,90

**OUT. 20** 

▼  
20 mm  
▲

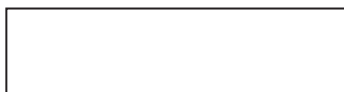

30x120  2  
DOLPHIN CLAY  
**DPR57100** rett. F 101,90

Per la serie completa vedi pag.294  
For the complete collection see page 294

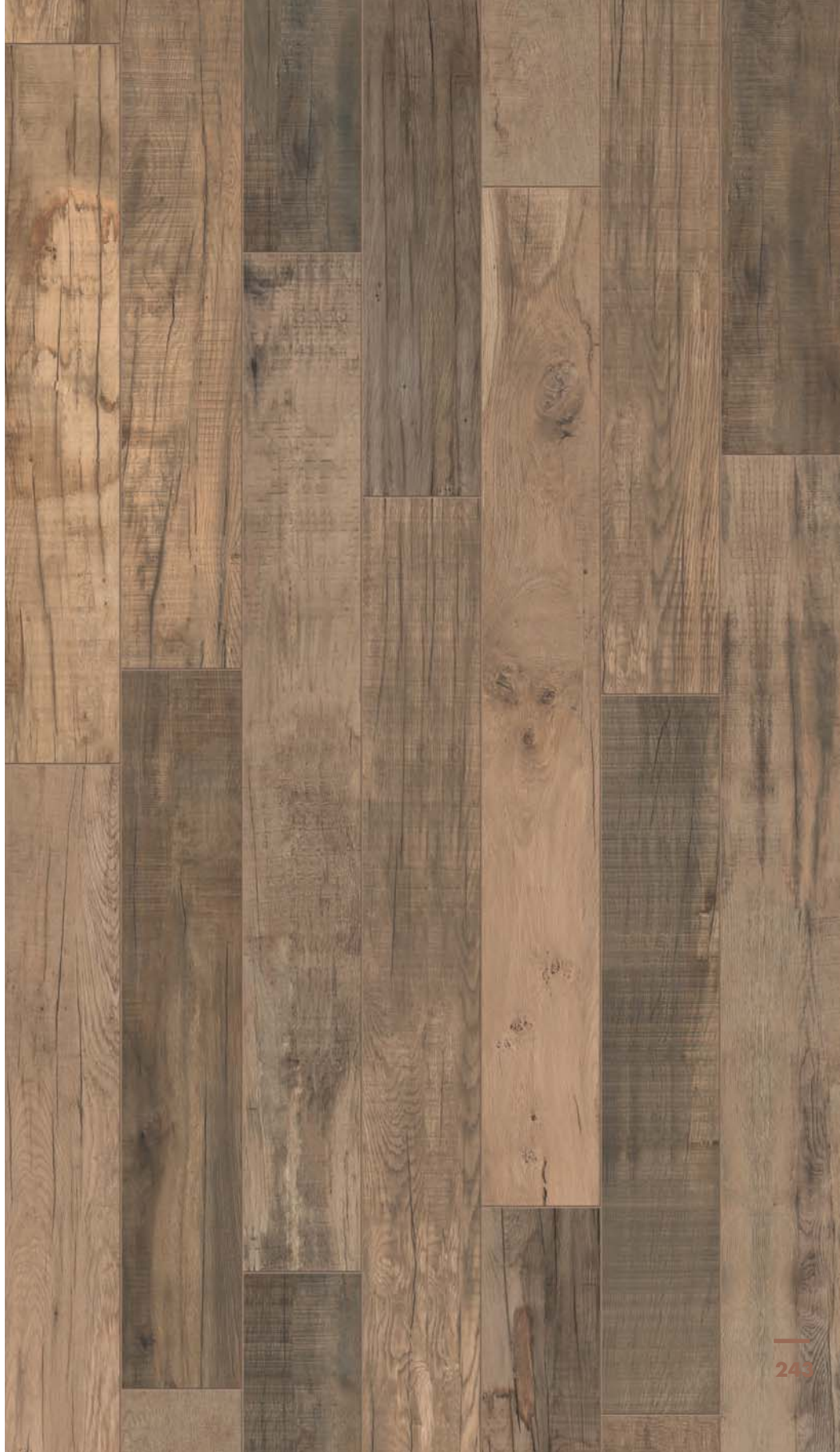

# Dolphin

OAK



40x170  2  
DOLPHIN OAK  
**DPR5615A** rett. F 91,90



20x170  4  
DOLPHIN OAK  
**DPR5516A** rett. F 91,90



20x120  6  
DOLPHIN OAK  
**DPR35150** rett. F 68,90



7x28  50  
DOLPHIN OAK SESTINO  
**DPR35160** rett. F 99,90

**OUTDOOR** 

 9 mm  





20x120  6  
DOLPHIN OAK  
**DPR35550** aged rett. F 68,90



**OUT.20** 

 20 mm  



30x120  2  
DOLPHIN OAK  
**DPR57150** rett. F 101,90





# Dolphin

MOON



40x170  2  
DOLPHIN MOON  
**DPR5620A** rett. F 91,90



20x170  4  
DOLPHIN MOON  
**DPR5520A** rett. F 91,90



20x120  6  
DOLPHIN MOON  
**DPR35200** rett. F 68,90

**OUTDOOR**  9 mm



20x120  6  
DOLPHIN MOON  
**DPR35700** aged rett. F 68,90







# Dolphin

GREY



40x170  2  
DOLPHIN GREY  
**DPR5625A** rett. F 91,90



20x170  4  
DOLPHIN GREY  
**DPR5525A** rett. F 91,90



20x120  6  
DOLPHIN GREY  
**DPR35250** rett. F 68,90

**OUTDOOR** 

 9 mm  

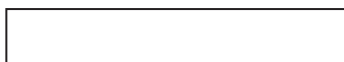



20x120  6  
DOLPHIN GREY  
**DPR35600** aged rett. F 68,90

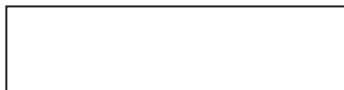

**OUT.20** 

 20 mm  

30x120  2  
DOLPHIN GREY  
**DPR57250** rett. F 101,90

Per la serie completa vedi pag. 294  
For the complete collection see page 294





# Dolphin

COAL

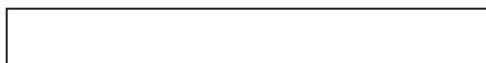

40x170  2  
DOLPHIN COAL  
**DPR5630A** rett. F 91,90



20x170  4  
DOLPHIN COAL  
**DPR5530A** rett. F 91,90



20x120  6  
DOLPHIN COAL  
**DPR35300** rett. F 68,90





7x28  50  
DOLPHIN COAL SESTINO  
**DPR35310** rett. F 99,90

**OUTDOOR**

**R11**

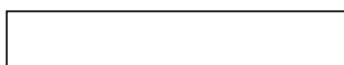
 9 mm  

20x120  6  
DOLPHIN COAL  
**DPR35750** aged rett. F 68,90

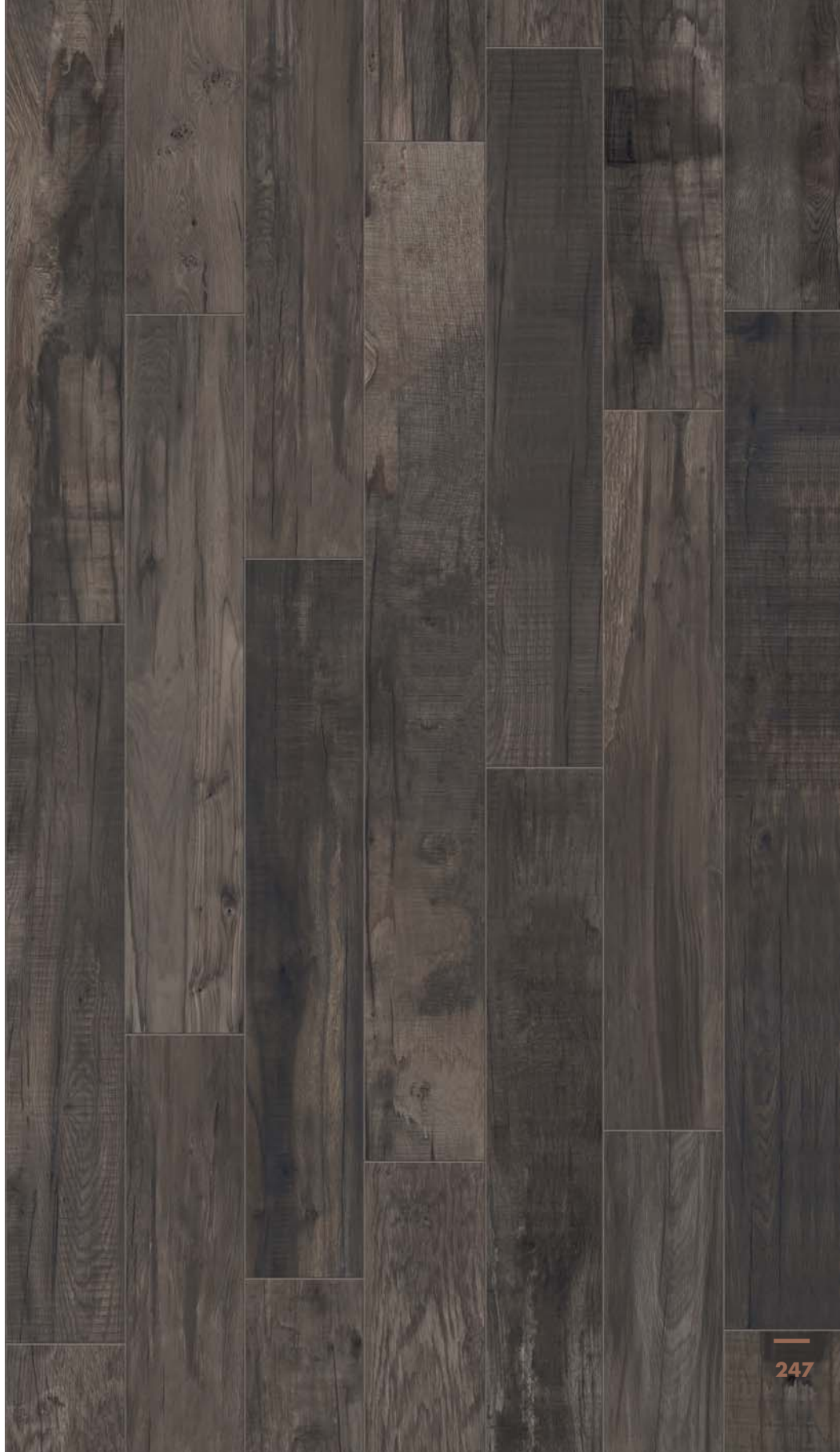

# Dolphin



20x120  3  
LISTONE CLAY PAINT MIX 3  
DPR35105 rett. PZ 85,90

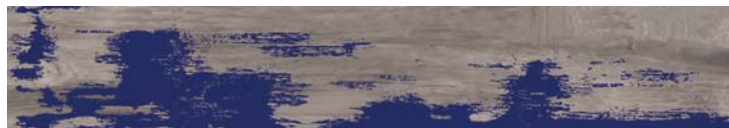

20x120  3  
LISTONE GREY ENAMEL MIX 3  
DPR35255 rett. PZ 85,90



20x15  6  
SNIP PAINT MIX 6 (5x20+10x20+15x20)  
DPR35106 rett. PZ 119,90  
(prezzo a cp.)

wall. Moon rett. 20x120, Tozz. Snip Paint mix 6





wall. DO UP Street White matt 60x120 floor. Clay rett. 20x120 - 20x170, Listone Clay Paint Mix 3 20x120



# Dolphin

floor. Dolphin grey 20x120 - Gradone top grey 32x120x4,5x2



## SCHEMI DI POSA INSTALLATION PATTERNS

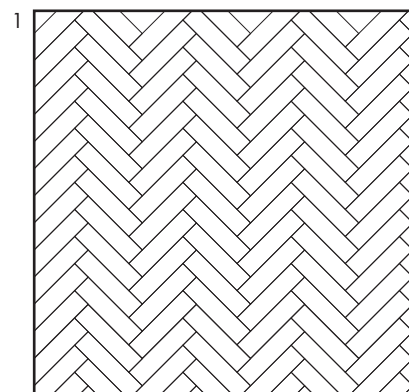

7x28 SESTINO

100 %

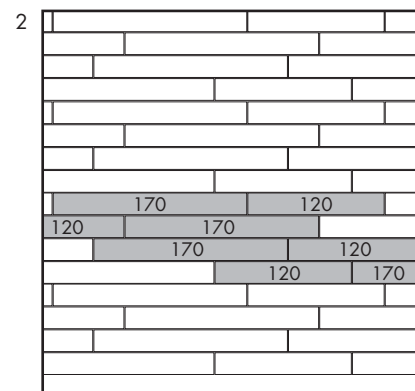

20x120

41,40 %

20x170

58,60 %

( MODULO FISSO - FIX MODULE )

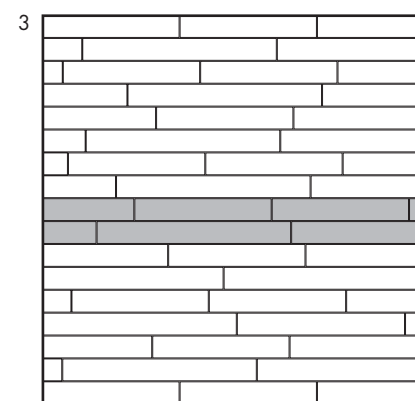

20x120

50 %

20x170



50 %

( A FILE ALTERNATE / ALTERNATE LINES )



# Dolphin



## PEZZI SPECIALI / SPECIAL TRIMS

	MILK	CLAY	OAK	MOON	GREY	COAL
 BATTISCOPA rett. 6,5x120 PZ 10,90  6	DPR35051	DPR35101	DPR35151	DPR35201	DPR35251	DPR35301
 ELEMENTO L 15x60x4 PZ 45,90  4	DPR35501 MILK AGED	DPR35651 CLAY AGED	DPR35551 OAK AGED	DPR35701 MOON AGED	DPR35601 GREY AGED	DPR35751 COAL AGED
 GRADONE TOP rett. 32x120x4,5x2 PZ 172,90  1	DPR35053	DPR35103	DPR35153	DPR35203	DPR35253	DPR35303
 ANGOLARE TOP SX 32x120x4,5x2 PZ 198,90  1  ANGOLARE TOP DX 32x120x4,5x2 PZ 198,90  1	DPR35054	DPR35104	DPR35154	DPR35204	DPR35254	DPR35304
	DPR35055	DPR35107	DPR35155	DPR35205	DPR35257	DPR35305

## IMBALLI/PACKAGING

F.to nominale Nominal size	F.to reale (mm) Real size (mm)	Spessore Thickness	Pz/Scatola Pcs/Box	Mq/Scatola Sqm/Box	Kg/Scatola Kg/Box	Scatole/Imballo Box/Packing	Mq totali Sqm total	Kg totali Kg total
* 40x170 / 16"x68" rett.	400x1700	9 mm	2	1,36	27,00	32	43,52	908
* 20x170 8"x68" rett.	199x1700	9 mm	4	1,36	27,00	36	48,96	1016
20x120 / 8"x48" rett.	199x1194	9 mm	6	1,44	27,20	36	51,84	1000
7x28 / 3"x11" rett.	-	9 mm	50	0,98	19,00	-	-	-
30x120 / 12"x48" rett.	295x1200	20 mm	2	0,72	32,90	30	21,60	1030

L'unità minima di vendita per tutti gli articoli (fondi, decori e pezzi speciali) è la scatola completa. / The minimum sales quantity for all items (plain tiles, decorations and special trims) is one full box.  
I dati relativi agli imballi sono aggiornati al momento della stampa del catalogo e pertanto possono subire variazioni nel corso del tempo. / Data referring to packaging have been update at time of printing; the actual data may be slightly different.  
Pezzi speciali e decori per effetto delle lavorazioni, possono presentare variazioni di tonalità. / Due to working process special trims and decors, may show variation in tonality.

	SIGILLANTI COORDINATI PER FUGHE / COORDINATED GROUT SEALANTS			COLLANTI / ADHESIVES	
	DOLPHIN	COLORE SIGILLANTE SEALANT COLOUR	CODICE SIGILLANTE SEALANT CODE		
	Dolphin Moon - Grey		SI123B kromos manhattan		
	Dolphin Milk		SI153B kromos tortora		
	Dolphin Coal		SI122B kromos antracite		
	Dolphin Oak		SI152B kromos ardesia		
	Dolphin Clay		SI154B kromos avana		
			* Vedi tabella imballi / * See at packaging list		
			Baulite S2 Bianco AD340M	+30 Bianco AD330M	
			Baulite S2 Grigio AD341M	+30 Grigio AD331M	

Per una migliore resa estetica e tecnica ABK consiglia l'utilizzo di sigillanti e collanti HARDKOLL come da tabella. Per listino, scheda tecnica e approfondimenti vedi pag. 370  
ABK suggests Hardkoll sealants and adhesives for a better aesthetics and technical efficiency, as follow. Read more at page 370 for prices and technical data sheets.



# Soleras

**AUTO-LEVELING™**

 Facile installazione - Easy laying

## GRES PORCELLANATO A MASSA COLORATA

FULL BODY COLORED PORCELAIN STONEWARE

## SUPERFICI SURFACES

naturale - natural

grip R11 - antislippery R11

## FORMATI SIZES

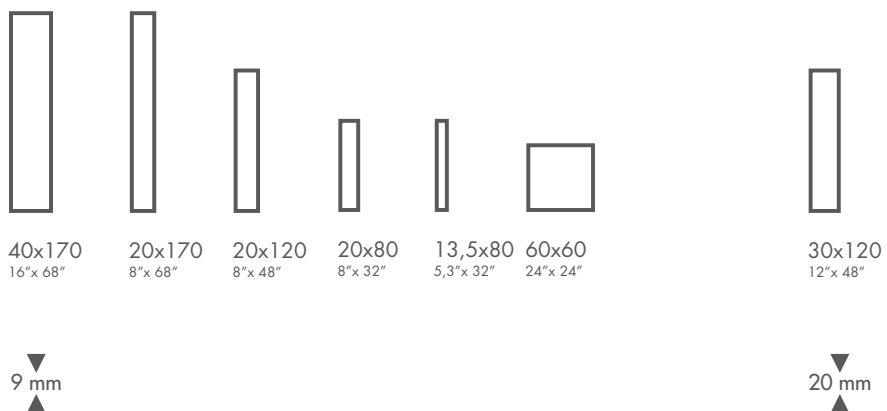

Classificazione secondo norme UNI EN 14411 (ISO 13006) Allegato G Gruppo Bla

Classification in accordance with UNI EN 14411 (ISO 13006) Annex G-Group Bla

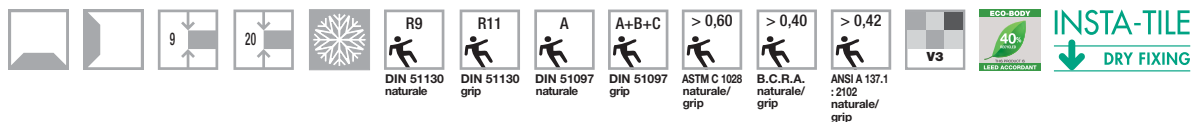

The image displays five horizontal swatches of wood grain textures, each with a different color treatment. From top to bottom: 1. 'NATURALE' (Natural): Shows the raw wood grain in its natural light tan color. 2. 'BEIGE' (Beige): The wood is stained to a uniform light beige color. 3. 'AVANA' (Ava): The wood is stained to a medium brown, almost blackish-brown color, highlighting the grain and knots. 4. 'BIANCO' (White): The wood is painted or stained white, with some natural grain patterns still visible. 5. 'ANTRACITE' (Anthracite): The wood is stained a dark charcoal or grey color, giving it a weathered, industrial look. Each swatch is labeled with its name in bold, black, uppercase letters on the left side.

**NATURALE**

**BEIGE**

**AVANA**

**BIANCO**

**GRIGIO**

**ANTRACITE**



# Soleras

floor. Naturale 40x170





floor. Grigio 20x170



# Soleras

## NATURALE



40x170  2  
SOLERAS NATURALE

**S1R5620A** rett. F 91,90



20x170  4  
SOLERAS NATURALE

**S1R5520A** rett. F 91,90



20x120  6  
SOLERAS NATURALE

**S1R35200** rett. F 68,90



20x80  8  
SOLERAS NATURALE

**S1R4920B** rett. F 57,90

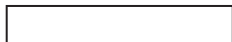

13,5x80  10  
SOLERAS NATURALE

**S1R48200** rett. F 62,90

**OUTDOOR** 

  
9 mm  



20x80  8  
SOLERAS NATURALE GRIP

**S1R4965B** rett. F 57,90

**OUT.20** 

  
20 mm  



30x120  2  
SOLERAS NATURALE

**S1R57200** rett. F 101,90





# Soleras

BEIGE



20x120  6

SOLERAS BEIGE

**S1R35300** rett. F 68,90



20x80  8

SOLERAS BEIGE

**S1R4930B** rett. F 57,90



13,5x80  10

SOLERAS BEIGE

**S1R48300** rett. F 62,90





# Soleras

## AVANA

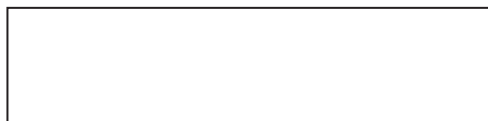

40x170 2  
SOLERAS AVANA  
**S1R5625A** rett. F 91,90

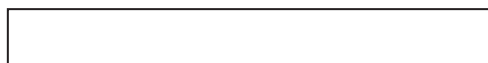

20x170 4  
SOLERAS AVANA  
**S1R5525A** rett. F 91,90



20x120 6  
SOLERAS AVANA  
**S1R35250** rett. F 68,90



20x80 8  
SOLERAS AVANA  
**S1R4925B** rett. F 57,90

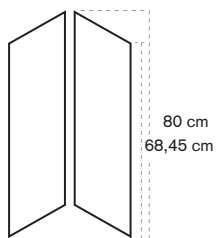
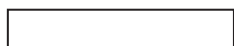

13,5x80 10  
SOLERAS AVANA  
**S1R48250** rett. F 62,90

20x80 6  
SOLERAS AVANA FRENCH PATTERN  
**S1R4926A** rett. F 91,90

**OUTDOOR**

9 mm

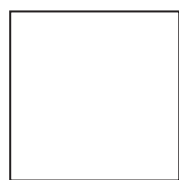

20x80 8  
SOLERAS AVANA GRIP  
**S1R4970B** rett. F 57,90

60x60 3  
SOLERAS AVANA  
**S1R01250** rett. F 53,90

**OUT.20**

20 mm



30x120 2  
SOLERAS AVANA  
**S1R57250** rett. F 101,90



# Soleras

BIANCO



40x170  2  
SOLERAS BIANCO  
**S1R5605A** rett. F 91,90



20x170  4  
SOLERAS BIANCO  
**S1R5505A** rett. F 91,90



20x120  6  
SOLERAS BIANCO  
**S1R35050** rett. F 68,90



20x80  8  
SOLERAS BIANCO  
**S1R4905B** rett. F 57,90

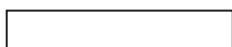

13,5x80  10  
SOLERAS BIANCO  
**S1R48050** rett. F 62,90

**OUTDOOR** 

 9 mm  





20x80  8  
SOLERAS BIANCO GRIP  
**S1R4950B** rett. F 57,90

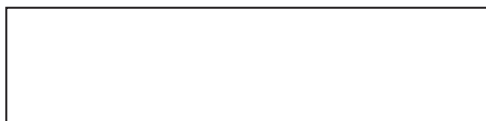

# Soleras

GRIGIO



40x170 2  
SOLERAS GRIGIO  
**S1R5610A** rett. F 91,90



20x170 4  
SOLERAS GRIGIO  
**S1R5510A** rett. F 91,90

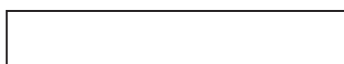

20x120 6  
SOLERAS GRIGIO  
**S1R35100** rett. F 68,90

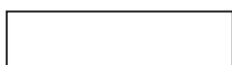

20x80 8  
SOLERAS GRIGIO  
**S1R4910B** rett. F 57,90

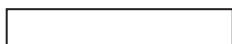
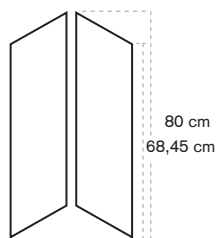

13,5x80 10  
SOLERAS GRIGIO  
**S1R48100** rett. F 62,90

20x80 6  
SOLERAS GRIGIO FRENCH PATTERN  
**S1R4911A** rett. F 91,90

**OUTDOOR**

9 mm



20x80 8  
SOLERAS GRIGIO GRIP  
**S1R4955B** rett. F 57,90



60x60 3  
SOLERAS GRIGIO  
**S1R01100** rett. F 53,90







# Soleras

ANTRACITE



20x120  6  
SOLERAS ANTRACITE  
**S1R35150** rett. F 68,90



20x80  8  
SOLERAS ANTRACITE  
**S1R4915B** rett. F 57,90





13,5x80  10  
SOLERAS ANTRACITE  
**S1R48150** rett. F 62,90





# Soleras

5x80  4  
LIST. SOLERAS AVANA  
**S1R49255** rett. PZ 6,90

5x60  8  
LISTONE BEIGE (coll.DOCKS)  
**S1R01255** rett. F 104,90

5x5  8  
TOZZETTO BEIGE (coll.DOCKS)  
**S1R01256** rett. F 104,90

5x80  4  
LIST. SOLERAS ANTRACITE  
**S1R49155** rett. PZ 6,90

5x60  8  
LISTONE GRIGIO (coll.DOCKS)  
**S1R01105** rett. F 104,90

5x5  8  
TOZZETTO GRIGIO (coll.DOCKS)  
**S1R01106** rett. F 104,90

5x40  4  
\*LISTELLO WOOD  
**DKR51055** rett. PZ 19,90

\* Antico legno alpino recuperato da costruzioni dismesse e trattato per l'utilizzo in parete e a pavimento.  
Ogni pezzo è unico e irripetibile.  
Antique alpin wood, recovered from discontinued buildings and treated for floor and wall use.  
Every single piece turns out to be different and unique.

\* Art. realizzati con materiali naturali:  
vedi indicazioni per posa e pulizia a pag. 393 dell' area tecnica.  
Items produced with natural materials:  
check the technical area at page 393.

0,5x120  4  
MATITA ALLUMINIO  
**0000086** PZ 20,90

0,5x120  4  
MATITA ALLUMINIO WHITE  
**0000087** PZ 34,90

0,5x120  4  
MATITA ALLUMINIO BLACK  
**0000088** PZ 34,90

0,5x120  4  
MATITA ALLUMINIO RAME  
**0000556** PZ 34,90

0,5x120  4  
MATITA ALLUMINIO BRONZO  
**0000557** PZ 34,90

## PEZZI SPECIALI / SPECIAL TRIMS

						
	NATURALE	BEIGE	AVANA	BIANCO	GRIGIO	ANTRACITE
 BATTISCOPA 6,5x80 PZ 8,90  8	<b>S1R49201</b>	<b>S1R49301</b>	<b>S1R49251</b>	<b>S1R49051</b>	<b>S1R49101</b>	<b>S1R49151</b>
 GRADINO L. GRIP 20x40x4 PZ 41,90  2	<b>S1R49651</b> GRIP	-	<b>S1R49701</b> GRIP	<b>S1R49501</b> GRIP	<b>S1R49551</b> GRIP	-
 COMP. SCALINO rett. 35x80x4 PZ 82,90 (prezzo a comp.)  1 cp./box	<b>S1R49206</b>	<b>S1R49306</b>	<b>S1R49256</b>	<b>S1R49056</b>	<b>S1R49106</b>	<b>S1R49156</b>
 AE rett. 12,5x40x3 PZ 27,90  4	<b>S1R49207</b>	<b>S1R49307</b>	<b>S1R49257</b>	<b>S1R49057</b>	<b>S1R49107</b>	<b>S1R49157</b>
 GRADONE TOP rett. 32x120x4,5x2 PZ 172,90  1	<b>S1R55203</b>	<b>S1R55303</b>	<b>S1R55253</b>	<b>S1R55053</b>	<b>S1R55103</b>	<b>S1R55153</b>
 ANGOLARE TOP SX 32x120x4,5x2 PZ 198,90  1  ANGOLARE TOP DX 32x120x4,5x2 PZ 198,90  1	<b>S1R55204</b>	<b>S1R55304</b>	<b>S1R55254</b>	<b>S1R55054</b>	<b>S1R55104</b>	<b>S1R55154</b>
	<b>S1R55205</b>	<b>S1R55305</b>	<b>S1R55255</b>	<b>S1R55055</b>	<b>S1R55105</b>	<b>S1R55155</b>

# Soleras

SCHEMI DI POSA / INSTALLATION PATTERNS

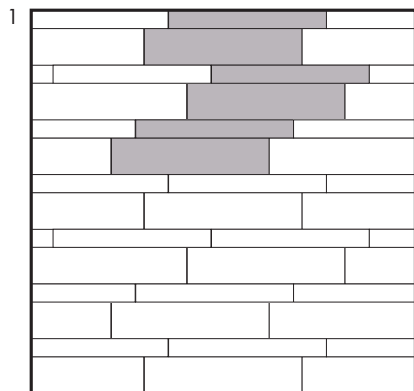

40x170	66,7 %
20x170	33,3 %

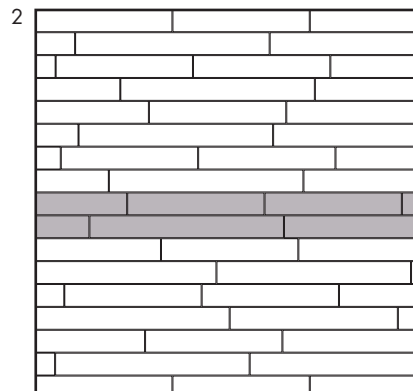

20x170	50 %
20x120	50 %

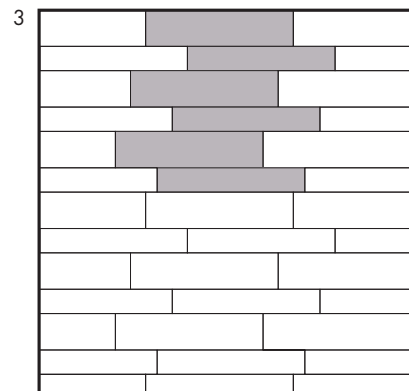

20x80	59,7 %
13,5x80	40,3 %

## IMBALLI/PACKAGING

F.to nominale Nominal size	F.to reale (mm) Real size (mm)	Spessore Thickness	Pz/Scatola Pcs/Box	Mq/Scatola Sqm/Box	Kg/Scatola Kg/Box	Scatole/Imballo Box/Packing	Mq totali Sqm total	Kg totali Kg total
*40x170 / 16"x68" rett.	400x1700	9 mm	2	1,36	27,00	32	43,52	908
*20x170 / 8"x68" rett.	199x1700	9 mm	4	1,36	27,00	36	48,96	1016
20x120 / 8"x48" rett.	199x1194	9 mm	6	1,44	27,20	36	51,84	1000
20x80 / 8"x32" rett.	199x800	9 mm	8	1,28	24,00	42	53,76	1028
20x80 / 8"x32" French Pattern	199x800	9 mm	6	0,82	17,38	36	29,52	646
13,5x80 / 5.3"x32" rett.	132x800	9 mm	10	1,08	20,00	40	43,20	820
60x60 / 24"x24" rett.	596x596	9 mm	3	1,08	21,20	40	43,20	868
30x120 / 12"x48" rett.	295x1200	20 mm	2	0,72	32,90	30	21,60	1030

L'unità minima di vendita per tutti gli articoli (fondi, decori e pezzi speciali) è la scatola completa. / The minimum sales quantity for all items (plain tiles, decorations and special trims) is one full box.  
I dati relativi agli imballi sono aggiornati al momento della stampa del catalogo e pertanto possono subire variazioni nel corso del tempo. / Data referring to packaging have been update at time of printing; the actual data may be slightly different.

Pezzi speciali e decori per effetto delle lavorazioni, possono presentare variazioni di tonalità. / Due to working process special trims and decors, may show variation in tonality.

## SIGILLANTI COORDINATI PER FUGHE / COORDINATED GROUT SEALANTS

SOLERAS	COLORE SIGILLANTE SEALANT COLOUR	CODICE SIGILLANTE SEALANT CODE
Soleras Bianco		SI120B kromos grigio luce
Soleras Grigio		SI123B kromos manhattan
Soleras Antracite		SI152B kromos ardesia
Soleras Naturale		SI153B kromos tortora
Soleras Avana		SI154B kromos avana
Soleras Beige		SI153B kromos tortora

## COLLANTI / ADHESIVES



\*Vedi tabella imballi /  
\*See at packaging list

Baulite S2 Bianco AD340M  
Baulite S2 Grigio AD341M



+30 Bianco AD330M  
+30 Grigio AD331M

**HARDKOLL**  
LIVING INNOVATIONS



# Playwood

---

**GRES PORCELLANATO**  
PORCELAIN STONEWARE

**SUPERFICI** SURFACES

naturale - natural

**FORMATI** SIZES



20,2x80,2  
8"x 32"

▼  
9 mm  
▲



BONE



EARTH



GREY

---

Classificazione secondo norme UNI EN 14411 (ISO 13006) Allegato G Gruppo BIa GL  
Classification in accordance with UNI EN 14411 (ISO 13006) Annex G-Group BIa GL





# Playwood

## BONE



20,2x80,2  7  
PLAYWOOD BONE

**PWN49050** nat. F 41,90

## EARTH



20,2x80,2  7  
PLAYWOOD EARTH

**PWN49100** nat. F 41,90

## GREY



20,2x80,2  7  
PLAYWOOD GREY

**266** **PWN49150** nat. F 41,90



# Playwood

## PEZZI SPECIALI / SPECIAL TRIMS

				
		PLAYWOOD BONE	PLAYWOOD EARTH	PLAYWOOD GREY
	BATTISCOPA 6,5x80,2 PZ 8,90  8	<b>PWN49051</b>	<b>PWN49101</b>	<b>PWN49151</b>

## IMBALLI/PACKAGING

F.to nominale Nominal size	F.to reale (mm) Real size (mm)	Spessore Thickness	Pz/Scatola Pcs/Box	Mq/Scatola Sqm/Box	Kg/Scatola Kg/Box	Scatole/Imballo Box/Packing	Mq totali Sqm total	Kg totali Kg total
20,2x80,2 nat. / 8"x32"	-	9 mm	7	1,14	21,89	42	47,88	940

L'unità minima di vendita per tutti gli articoli (fondi, decori e pezzi speciali) è la scatola completa. / The minimum sales quantity for all items (plain tiles, decorations and special trims) is one full box.  
I dati relativi agli imballi sono aggiornati al momento della stampa del catalogo e pertanto possono subire variazioni nel corso del tempo. / Data referring to packaging have been update at time of printing; the actual data may be slightly different.  
Pezzi speciali e decori per effetto delle lavorazioni, possono presentare variazioni di tonalità. / Due to working process special trims and decors, may show variation in tonality.

## SIGILLANTI COORDINATI PER FUGHE / COORDINATED GROUT SEALANTS

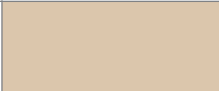
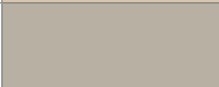
PLAYWOOD	COLORE SIGILLANTE SEALANT COLOUR	CODICE SIGILLANTE SEALANT CODE
Playwood Bone - Earth		SI129B kromos bahama beige
Playwood Grey		SI123B kromos manhattan

## COLLANTI / ADHESIVES



Baulite S2 Bianco AD340M

Baulite S2 Grigio AD341M



+30 Bianco AD330M

+30 Grigio AD331M

Per una migliore resa estetica e tecnica ABK consiglia l'utilizzo di sigillanti e collanti HARDKOLL come da tabella. Per listino, scheda tecnica e approfondimenti vedi pag. 370  
ABK suggests Hardkoll sealants and adhesives for a better aesthetics and technical efficiency, as follow. Read more at page 370 for prices and technical data sheets.

# Petraia

## GRES PORCELLANATO PORCELAIN STONEWARE

### SUPERFICI SURFACES

naturale - natural  
grip - antislippery

### FORMATI SIZES

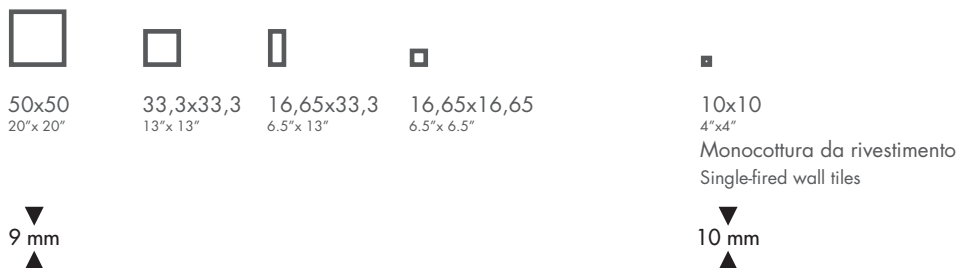

Classificazione secondo norme UNI EN 14411 (ISO 13006) Allegato G Gruppo Bla GL  
Classification in accordance with UNI EN 14411 (ISO 13006) Annex G-Group Bla GL

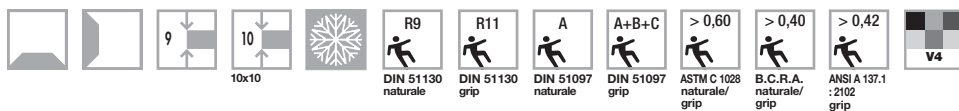







# Petraia

ROSSO



50x50  4  
 PETRAIA ROSSO  
**A61170A** F 36,90



33,3x33,3  11  
 PETRAIA ROSSO  
**A8537H** F 31,90  
**A8537GH** grip F 36,90



16,65x33,3  22  
 PETRAIA ROSSO TAVELLA DA PRESSA  
**A8537PC** F 36,90  
**A8537PGC** grip F 36,90



16,65x16,65  44  
 PETRAIA ROSSO TOZZETTO  
**A85378P** F 42,90



33,3x33,3  5  
 MOS. QUADRETTI ROSSO  
**A8537U** PZ 16,90

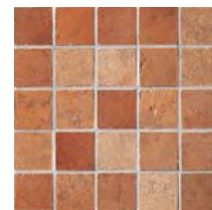

33,3x33,3  5  
 MOS. QUADRETTI OCRA/CO./RO.  
**A8525UM** PZ 16,90



25x35  8  
 PARQUET  
**A5017A** PZ 17,90



12,5x25  8  
 FRECCIA TRIANGOLI  
**A5017H** PZ 11,90



4x36  10  
 RACCORDO PARQUET  
**A5017M** PZ 9,90



12,5x25  8  
 FRECCIA RETTANGOLI  
**A5017G** PZ 9,90



12,5x12,5  12  
 TOZZETTO ARALDICO (2 SOGG.)  
**A5017B** PZ 17,90



2,5x12,5  20  
 Q. ROUND ROSSO  
**A501711** PZ 6,90



2,5x1  20  
 SGUSCIA ROSSO  
**A501712** PZ 12,90

# Petraia

COTTO



50x50  4  
PETRAIA COTTO  
**A61070A**

F 36,90



33,3x33,3  11  
PETRAIA COTTO  
**A8527H**  
**A8527GH** grip

F 31,90  
F 36,90



16,65x33,3  22  
PETRAIA COTTO TAVELLA DA PRESSA  
**A8527PC**  
**A8527PGC** grip

F 36,90  
F 36,90



16,65x16,65  44  
PETRAIA COTTO TOZZETTO  
**A85278P**

F 42,90



33,3x33,3  5  
MOS. QUADRETTI COTTO  
**A8527U**

PZ 16,90



33,3x33,3  5  
MOS. QUADRETTI OCRA/CO./RO.  
**A8525UM**

PZ 16,90



25x35  8  
PARQUET  
**A5007A**

PZ 17,90



12,5x25  8  
FRECCIA TRIANGOLI  
**A5017H**

PZ 11,90



4x36  10  
RACCORDO PARQUET  
**A5007M**

PZ 9,90



12,5x25  8  
FRECCIA RETTANGOLI  
**A5007G**

PZ 9,90



12,5x12,5  12  
TOZZETTO ARALDICO (2 SOGG.)  
**A5017B**

PZ 17,90



2,5x12,5  20  
Q. ROUND COTTO  
**A500711**

PZ 6,90



2,5x1  20  
SGUSCIA COTTO  
**A500712**

PZ 12,90

# Petraia

OCRA



50x50  4  
PETRAIA OCRA  
**A61050A**

F 36,90



33,3x33,3  11  
PETRAIA OCRA

**A8525H** F 31,90  
**A8525GH** grip F 36,90



16,65x33,3  22  
PETRAIA OCRA TAVELLA DA PRESSA  
**A8525PC** F 36,90  
**A8525PGC** grip F 36,90



16,65x16,65  44  
PETRAIA OCRA TOZZETTO  
**A50058P** F 42,90



33,3x33,3  5  
MOS. QUADRETTI OCRA  
**A8525U** PZ 16,90



33,3x33,3  5  
MOS. QUADRETTI OCRA/CO./RO.  
**A8525UM** PZ 16,90



25x35  8  
PARQUET  
**A5005A** PZ 17,90



12,5x25  8  
FRECCIA TRIANGOLI  
**A5017H** PZ 11,90



4x36  10  
RACCORDO PARQUET  
**A5005M** PZ 9,90



12,5x25  8  
FRECCIA RETTANGOLI  
**A5005G** PZ 9,90



12,5x12,5  12  
TOZZETTO ARALDICO (2 SOGG.)  
**A5005B** PZ 17,90



2,5x12,5  20  
Q. ROUND OCRA  
**A500511** PZ 6,90



2,5x1  20  
SGUSCIA OCRA  
**A500512** PZ 12,90



5x12,5  12  
VCAP OCRA  
**A50054** PZ 8,90



5x5  20  
C-CAP OCRA  
**A50055** PZ 16,90



# Petraia

BEIGE



50x50  4  
PETRAIA BEIGE  
**A61000A**

F 36,90



33,3x33,3  11  
PETRAIA BEIGE  
**A8520H**  
**A8520GH** grip

F 31,90  
F 36,90



16,65x33,3  22  
PETRAIA BEIGE TAVELLA DA PRESSA  
**A8520PC**  
**A8520PGC** grip

F 36,90  
F 36,90



16,65x16,65  44  
PETRAIA BEIGE TOZZETTO  
**A85208P**

F 42,90



33,3x33,3  5  
MOS. QUADRETTI BEIGE  
**A8520U**

PZ 16,90

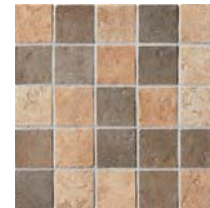

33,3x33,3  5  
MOS. QUADRETTI BEIGE/NERO  
**A8520UM**

PZ 16,90



25x35  8  
PARQUET  
**A5000A**

PZ 17,90



12,5x25  8  
FRECCIA TRIANGOLI  
**A5000H**

PZ 11,90



4x36  10  
RACCORDO PARQUET  
**-A5000.M**

PZ 9,90



12,5x25  8  
FRECCIA RETTANGOLI  
**A5000G**

PZ 9,90



12,5x12,5  12  
TOZZETTO ARALDICO (2 SOGG.)  
**A5000B**

PZ 17,90



2,5x12,5  20  
Q. ROUND BEIGE  
**A500011**

PZ 6,90



2,5x1  20  
SGUSCIA BEIGE  
**A500012**

PZ 12,90

# Petraia

ALMOND



50x50  4  
PETRAIA ALMOND  
**A61040A**

F 36,90



33,3x33,3  11  
PETRAIA ALMOND  
**A8524H**

F 31,90



16,65x33,3  22  
PETRAIA ALMOND TAVELLA DA PRESSA  
**A8524PC**

F 36,90



33,3x33,3  5  
MOS. QUADRETTI ALMOND  
**A8524U**

PZ 16,90



25x35  8  
PARQUET  
**A5004A**

PZ 17,90



12,5x25  8  
FRECCIA TRIANGOLI  
**A5004H**

PZ 11,90



4x36  10  
RACCORDO PARQUET  
**A5004M**

PZ 9,90



12,5x25  8  
FRECCIA RETTANGOLI  
**A5004G**

PZ 9,90



12,5x12,5  12  
TOZZETTO ARALDICO (2 SOGG.)  
**A5004B**

PZ 17,90

# Petraia

NERO



33,3x33,3  11  
PETRAIA NERO

**A8526H** F 31,90



16,65x33,3  22  
PETRAIA NERO TAVELLA DA PRESSA

**A8526PC** F 36,90



33,3x33,3  5  
MOS. QUADRETTI NERO  
**A8526U**

PZ 16,90



33,3x33,3  5  
MOS. QUADRETTI BEIGE/NERO  
**A8520UM**

PZ 16,90



25x35  8  
PARQUET

**A5006A** PZ 17,90



4x36  10  
RACCORDO PARQUET

**A5006M** PZ 9,90



12,5x25  8  
FRECCIA RETTANGOLI  
**A5006G**

PZ 9,90



12,5x12,5  12  
TOZZETTO ARALDICO (2 SOGG.)  
**A5006B**

PZ 17,90



# Petraia

floor. Ocra grip 33,3x33,3 - 16,65x33,3





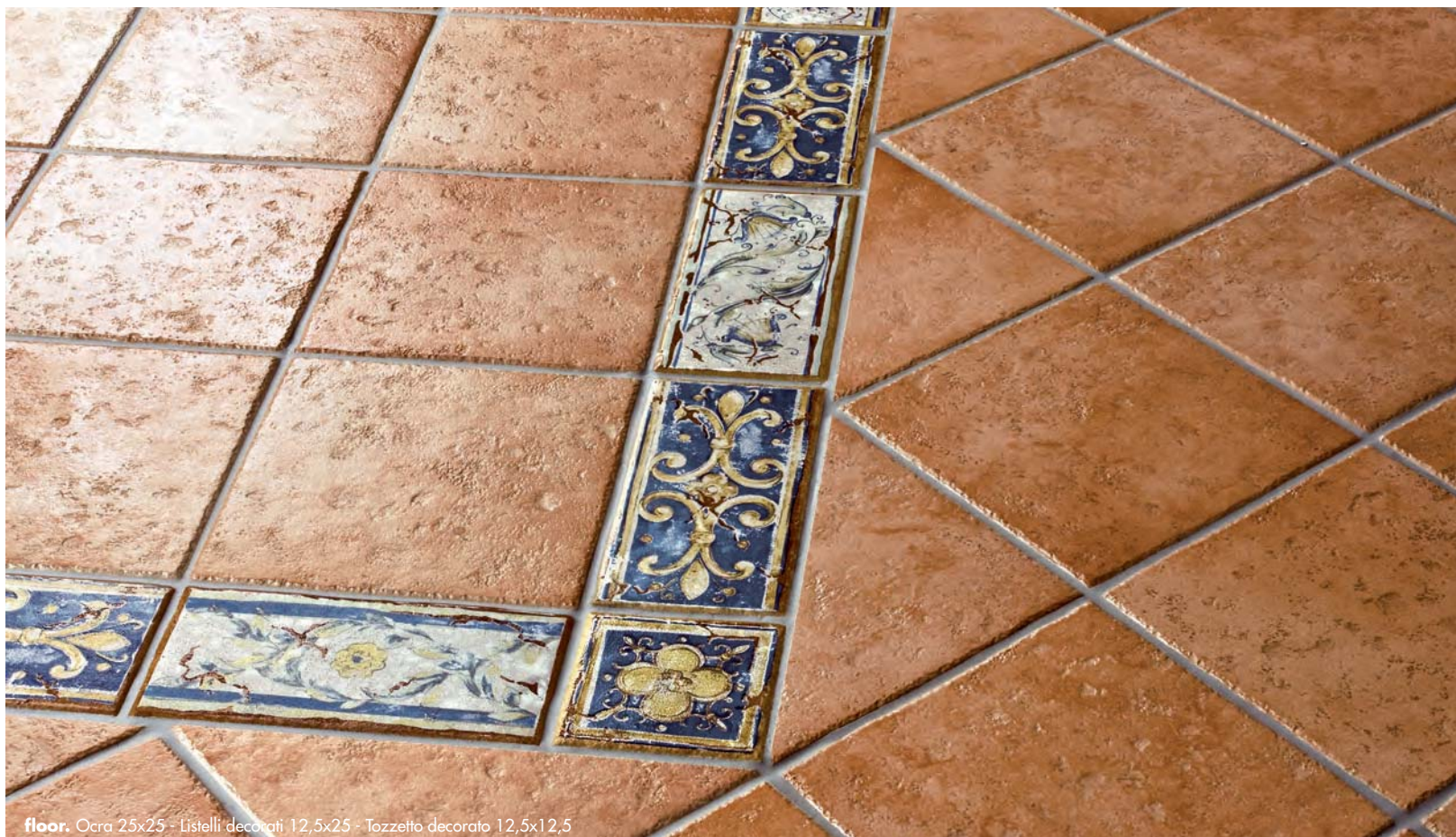

floor. Ocra 25x25 - Listelli decorati 12,5x25 - Tozzetto decorato 12,5x12,5

COORDINATI DA PAVIMENTO ABBINABILI A PETRAIA OCRA - ROSSO - COTTO. / FLOOR COORDINATED DECORS WHICH MATCH THE OCRA, ROSSO AND COTTO PETRAIA PLAIN TILES.



12,5x25 ☞ 4  
LISTELLO DECORATO  
**A5017V** PZ 12,90



12,5x25 ☞ 4  
LISTELLO DECORATO  
**A5017S** PZ 12,90



12,5x25 ☞ 4  
LISTELLO DECORATO  
**A5017Q** PZ 12,90



12,5x25 ☞ 4  
LISTELLO DECORATO  
**A5017J** PZ 12,90



25x25 ☞ 2  
INSERTO CHIANTI  
**A5007F** PZ 17,90



12,5x12,5 ☞ 4  
TOZZETTO DECORATO  
**A5017W** PZ 9,90



12,5x12,5 ☞ 4  
TOZZETTO DECORATO  
**A5017X** PZ 9,90



12,5x12,5 ☞ 4  
TOZZETTO DECORATO  
**A5017P** PZ 9,90



12,5x12,5 ☞ 4  
TOZZETTO DECORATO  
**A5017K** PZ 9,90

Si consiglia di pulire la superficie senza utilizzare prodotti contenenti sostanze abrasive.  
Do not use products containing abrasive substances to clean the decorative element.



# Petraia

MONOCOTTURA DA RIVESTIMENTO  
SINGLE-FIRED WALL TILES



10x10  $\square$  68  
PETRAIA BEIGE  
**A20000** PZ 40,90



10x10  $\square$  4  
DEC. ULIVETO MIX BEIGE  
**A20001** PZ 12,90



5x20  $\square$  4  
TORELLO BEIGE  
**A200026** PZ 13,90



5x3  $\square$  2  
ANG. TORELLO BEIGE  
**A200027** PZ 13,90



2x20  $\square$  4  
BOMBATO BEIGE  
**A200028** PZ 9,90



2x2  $\square$  2  
ANG. BOMBATO BEIGE  
**A200029** PZ 13,90



10x10  $\square$  4  
DEC. SOFFIO MIX BEIGE  
**A2000A** PZ 10,90



10x10  $\square$  4  
DEC. FIORITO MIX BEIGE  
**A2000C** PZ 7,90



5x20  $\square$  4  
LIST. SOFFIO BEIGE  
**A2000B** PZ 15,90



5x10  $\square$  4  
LIST. FIORITO MIX BEIGE  
**A2000D** PZ 4,90



10x10  $\square$  68  
PETRAIA ALMOND  
**A20040** PZ 40,90



10x10  $\square$  4  
DEC. ULIVETO MIX ALMOND  
**A2004I** PZ 12,90



5x20  $\square$  4  
TORELLO ALMOND  
**A200426** PZ 13,90



5x3  $\square$  2  
ANG. TORELLO ALMOND  
**A200427** PZ 13,90



2x20  $\square$  4  
BOMBATO ALMOND  
**A200428** PZ 9,90



2x2  $\square$  2  
ANG. BOMBATO ALMOND  
**A200429** PZ 13,90



10x10  $\square$  4  
DEC. SOFFIO MIX ALMOND  
**A2004A** PZ 10,90



10x10  $\square$  4  
DEC. FIORITO MIX ALMOND  
**A2004C** PZ 7,90



5x20  $\square$  4  
LIST. SOFFIO ALMOND  
**A2004B** PZ 15,90



5x10  $\square$  4  
LIST. FIORITO MIX ALMOND  
**A2004D** PZ 4,90





10x10  $\square$  68  
 PETRAIA BIANCO  
**A20010** F 40,90



10x10  $\square$  4  
 DEC. ULIVETO MIX BIANCO  
**A20011** PZ 12,90



5x20  $\square$  4  
 TORELLO BIANCO  
**A200126** PZ 13,90



5x3  $\square$  2  
 ANG. TORELLO BIANCO  
**A200127** PZ 13,90



2x20  $\square$  4  
 BOMBATO BIANCO  
**A200128** PZ 9,90



2x2  $\square$  2  
 ANG. BOMBATO BIANCO  
**A200129** PZ 13,90



10x10  $\square$  4  
 DEC. SOFFIO MIX BIANCO  
**A2001A** PZ 10,90



10x10  $\square$  4  
 DEC. FIORITO MIX BIANCO  
**A2001C** PZ 7,90



5x10  $\square$  4  
 LIST. FIORITO MIX BIANCO  
**A2001D** PZ 4,90



10x10  $\square$  68  
 PETRAIA OCRA  
**A20050** F 40,90



10x10  $\square$  4  
 DEC. ULIVETO MIX OCRA  
**A20051** PZ 12,90



5x20  $\square$  4  
 TORELLO OCRA  
**A200526** PZ 13,90



5x3  $\square$  2  
 ANG. TORELLO OCRA  
**A200527** PZ 13,90



2x20  $\square$  4  
 BOMBATO OCRA  
**A200528** PZ 9,90



2x2  $\square$  2  
 ANG. BOMBATO OCRA  
**A200529** PZ 13,90



10x10  $\square$  4  
 DEC. SOFFIO MIX OCRA  
**A2005A** PZ 10,90



10x10  $\square$  4  
 DEC. FIORITO MIX OCRA  
**A2005C** PZ 7,90



5x20  $\square$  4  
 LIST. SOFFIO OCRA  
**A2005B** PZ 15,90



5x10  $\square$  4  
 LIST. FIORITO MIX OCRA  
**A2005D** PZ 4,90



10x10  $\square$  3  
 FORM. FRUCTIS MIX OC/CO/RO.  
**A2005M** PZ 26,90



3,5x20  $\square$  4  
 LIST. FRUCTIS OC/CO/RO.  
**A2005N** PZ 17,90



10x10  $\square$  3  
 FORM. FRUCTIS MIX BE/BI/AL.  
**A2001M** PZ 26,90



3,5x20  $\square$  4  
 LIST. FRUCTIS BE/BI/AL.  
**A2001N** PZ 17,90



10x10  $\square$  4  
 FORM. MAIOLICA MIX ALMOND  
**A2000G** PZ 17,90



5x20  $\square$  4  
 LIST. MAIOLICA ALMOND  
**A2000H** PZ 17,90



10x10  $\square$  4  
 FORM. MAIOLICA MIX BIANCO  
**A2001G** PZ 17,90



5x20  $\square$  4  
 LIST. MAIOLICA BIANCO  
**A2001H** PZ 17,90

# Petraia

MONOCOTTURA DA RIVESTIMENTO  
SINGLE-FIRED WALL TILES

COORDINATI PER IL RIVESTIMENTO DI STRUTTURE IN MURATURA / COORDINATED TRIMS FOR BRICKWORK TILING



10x10 4  
PETRAIA BATTISTRACCIO PZ 20,90

<b>A200122</b>	BIANCO
<b>A200422</b>	ALMOND
<b>A200022</b>	BEIGE
<b>A200522</b>	OCRA



10x10 4  
PETRAIA PIANO LAVORO PZ 20,90

<b>A200118</b>	BIANCO
<b>A200418</b>	ALMOND
<b>A200018</b>	BEIGE
<b>A200518</b>	OCRA



10x10 2  
PETRAIA SPIGOLO PZ 24,90

<b>A200119</b>	BIANCO
<b>A200419</b>	ALMOND
<b>A200019</b>	BEIGE
<b>A200519</b>	OCRA



3x10 4  
PETRAIA Q.ROUND PZ 8,90

<b>A200111</b>	BIANCO
<b>A200411</b>	ALMOND
<b>A200011</b>	BEIGE
<b>A20011</b>	OCRA



3x3 2  
PETRAIA ANG. Q.ROUND PZ 19,90

<b>A200112</b>	BIANCO
<b>A200412</b>	ALMOND
<b>A200012</b>	BEIGE
<b>A200512</b>	OCRA



5x10 4  
PETRAIA V-CAP PZ 9,90

<b>A20014</b>	BIANCO
<b>A20044</b>	ALMOND
<b>A20004</b>	BEIGE
<b>A20054</b>	OCRA



5x3 2  
PETRAIA ANG. V-CAP PZ 22,90

<b>A20015</b>	BIANCO
<b>A20045</b>	ALMOND
<b>A20005</b>	BEIGE
<b>A20055</b>	OCRA

## IMBALLI/PACKAGING

F.to nominale Nominal size	F.to reale (mm) Real size (mm)	Spessore Thickness	Pz/Scatola Pcs/Box	Mq/Scatola Sqm/Box	Kg/Scatola Kg/Box	Scatole/Imballo Box/Packing	Mq totali Sqm total	Kg totali Kg total
50x50 / 20"x20" nat.	-	9 mm	4	1,00	20,00	36	36,00	740
33,3x33,3 / 13"x13" nat.	-	9 mm	11	1,22	21,50	44	53,68	966
16,65x33,3 / 6.5"x13" nat.	-	9 mm	22	1,22	21,50	44	53,68	966
16,65x16,65 / 6.5"x6.5" nat.	-	9 mm	44	1,22	25,00	40	48,80	1020
10x10 / 4"x4" nat.	-	9 mm	68	0,68	13,00	72	48,96	956

L'unità minima di vendita per tutti gli articoli (fondi, decori e pezzi speciali) è la scatola completa. / The minimum sales quantity for all items (plain tiles, decorations and special trims) is one full box.

I dati relativi agli imballi sono aggiornati al momento della stampa del catalogo e pertanto possono subire variazioni nel corso del tempo. /

Data referring to packaging have been update at time of printing; the actual data may be slightly different.

Pezzi speciali e decori per effetto delle lavorazioni, possono presentare variazioni di tonalità. / Due to working process special trims and decors, may show variation in tonality.



# Petraia

## PEZZI SPECIALI / SPECIAL TRIMS

		ROSSO	COTTO	OCRA	BEIGE	ALMOND	NERO
	BATTISCOPIA 8x33,3 PZ 3,90  18	<b>A85376</b>	<b>A85276</b>	<b>A85256</b>	<b>A85206</b>	<b>A85246</b>	<b>A85266</b>
	GRADINO TORELLO 33,3x33,3 PZ 23,90  3	<b>A85379</b>	<b>A85279</b>	<b>A85259</b>	<b>A85209</b>	<b>A85249</b>	<b>A85269</b>
	ANGOLARE TORELLO 33,3x33,3 PZ 42,90  2	<b>A85375</b>	<b>A85275</b>	<b>A85255</b>	<b>A85205</b>	<b>A85245</b>	<b>A85265</b>
	ELEM. L MONOLITICO 33,3x16,65x5 PZ 17,90  8	<b>A85373</b>	<b>A85273</b>	<b>A85253</b>	<b>A85203</b>	-	-
	ELEM. L MONOLITICO GRIP 33,3x16,65x5 PZ 17,90  8	<b>A85373G GRIP</b>	<b>A85273G GRIP</b>	<b>A85253G GRIP</b>	<b>A85203G GRIP</b>	-	-
	GRAD. MONOLITICO 30x33,3 PZ 35,90  6	<b>A853711</b>	<b>A852711</b>	<b>A852511</b>	-	-	-
	ANG. MONOLITICO 33,3x33,3 PZ 69,90  4	<b>A853712</b>	<b>A852712</b>	<b>A852512</b>	-	-	-

## SIGILLANTI COORDINATI PER FUGHE / COORDINATED GROUT SEALANTS

## COLLANTI / ADHESIVES

	PETRAIA	COLORE SIGILLANTE SEALANT COLOUR	CODICE SIGILLANTE SEALANT CODE		
	Petraia Almond - Beige		SI129B kromos bahama beige		
	Petraia Rosso - Nero - Cotto - Ocra		SI121B kromos cemento		
	Petraia Rosso - Nero		SI122B kromos antracite		
				Bauflex Bianco AD200M	Bauflex Maxi S1 Bianco AD260M
				Bauflex Grigio AD210M	Bauflex Maxi S1 Grigio AD280M

Per una migliore resa estetica e tecnica ABK consiglia l'utilizzo di sigillanti e collanti HARDKOLL come da tabella. Per listino, scheda tecnica e approfondimenti vedi pag. 370  
 ABK suggests Hardkoll sealants and adhesives for a better aesthetics and technical efficiency, as follow. Read more at page 370 for prices and technical data sheets.



# Zanzibar

---

**GRES PORCELLANATO**  
PORCELAIN STONEWARE

**SUPERFICI** SURFACES

naturale - natural

**FORMATI** SIZES



50x50  
20"x 20"



33,3x33,3  
13"x 13"



9 mm

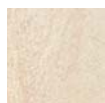

SABBIA CHIARO



SABBIA SCURO



GRIGIO CHIARO



GRIGIO SCURO

---

Classificazione secondo norme UNI EN 14411 (ISO 13006) Allegato G Gruppo B1a GL  
Classification in accordance with UNI EN 14411 (ISO 13006) Annex G-Group B1a GL

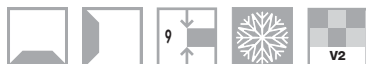





# Zanzibar

SABBIA CHIARO



SABBIA SCURO



50x50  4  
ZANZIBAR SABBIA CHIARO  
**ZA5000A** F 36,90



33,3x33,3  11  
ZANZIBAR SABBIA CHIARO  
**ZA6000C** F 31,90



33,3x33,3  5  
MOS. QUADRETTI SABBIA CHIARO  
**ZA6010** PZ 16,90



33,3x33,3  6  
MOS. BRICK SABBIA CHIARO  
**ZA6011** PZ 14,90



50x50  4  
ZANZIBAR SABBIA SCURO  
**ZA5500A** F 36,90



33,3x33,3  11  
ZANZIBAR SABBIA SCURO  
**ZA6500C** F 31,90



33,3x33,3  5  
MOS. QUADRETTI SABBIA SCURO  
**ZA6510** PZ 16,90



33,3x33,3  6  
MOS. BRICK SABBIA SCURO  
**ZA6511** PZ 14,90



2x33,3  12  
\*FASCIA SENSI SABBIA/OCRA  
**ZA6015** PZ 22,90



## GRIGIO CHIARO



50x50  4  
ZANZIBAR GRIGIO CHIARO  
**ZA5050A** F 36,90



33,3x33,3  11  
ZANZIBAR GRIGIO CHIARO  
**ZA6050C** F 31,90



33,3x33,3  5  
MOS. QUADRETTI GRIGIO CHIARO  
**ZA6060** PZ 16,90



33,3x33,3  6  
MOS. BRICK GRIGIO CHIARO  
**ZA6061** PZ 14,90

## GRIGIO SCURO

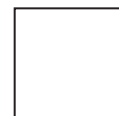
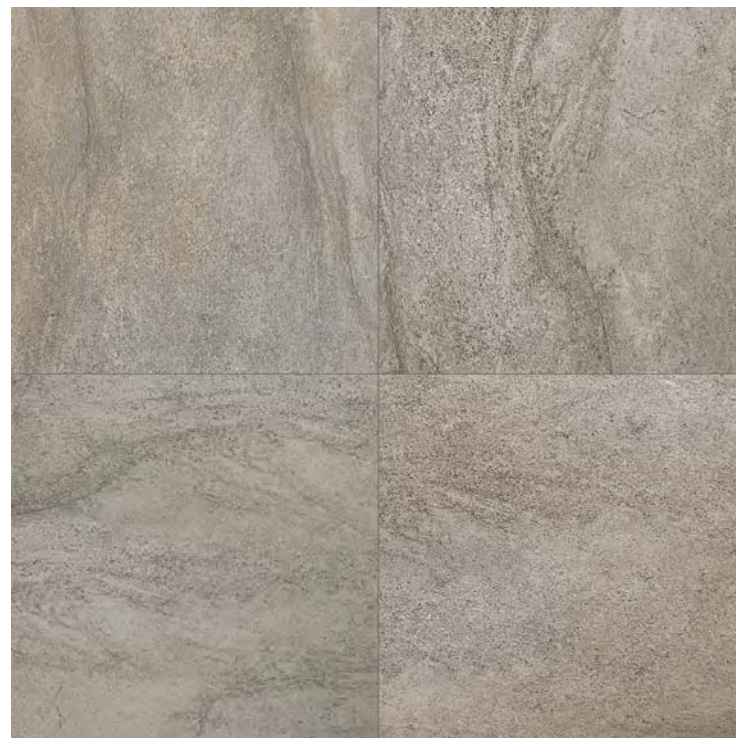

50x50  4  
ZANZIBAR GRIGIO SCURO  
**ZA5550A** F 36,90



33,3x33,3  11  
ZANZIBAR GRIGIO SCURO  
**ZA6550C** F 31,90



33,3x33,3  5  
MOS. QUADRETTI GRIGIO SCURO  
**ZA6560** PZ 16,90



33,3x33,3  6  
MOS. BRICK GRIGIO SCURO  
**ZA6561** PZ 14,90



2x33,3  12  
\*FASCIA SENSI GRIGIA  
**ZA6065** PZ 22,90

\*Coordinato da pavimento realizzato in pietra naturale e alluminio, ogni pezzo é unico e irripetibile.  
Floor coordinated tile made by combining the use of aluminum and natural stone. Every single piece turns out to be different and unique.

# Zanzibar



floor. Ocra scuro 50x50





# Zanzibar

## PEZZI SPECIALI / SPECIAL TRIMS

	SABBIA CHIARO	SABBIA SCURO	GRIGIO CHIARO	GRIGIO SCURO
 BATTISCOPA 8x33,3 PZ 3,90  18	<b>ZA6001</b>	<b>ZA6501</b>	<b>ZA6051</b>	<b>ZA6551</b>



## IMBALLI/PACKAGING

F.to nominale Nominal size	F.to reale (mm) Real size (mm)	Spessore Thickness	Pz/Scatola Pcs/Box	Mq/Scatola SqM/Box	Kg/Scatola Kg/Box	Scatole/Imballo Box/Packing	Mq totali SqM total	Kg totali Kg total
50x50 / 20"x20" nat.	-	9 mm	4	1,00	20,00	36	36,00	740
33,3x33,3 / 13"x13" nat.	-	9 mm	11	1,22	24,00	44	53,68	1076

L'unità minima di vendita per tutti gli articoli (fondi, decori e pezzi speciali) è la scatola completa. / The minimum sales quantity for all items (plain tiles, decorations and special trims) is one full box.  
 I dati relativi agli imballi sono aggiornati al momento della stampa del catalogo e pertanto possono subire variazioni nel corso del tempo. /  
 Data referring to packaging have been update at time of printing; the actual data may be slightly different.

Pezzi speciali e decori per effetto delle lavorazioni, possono presentare variazioni di tonalità. / Due to working process special trims and decors, may show variation in tonality.

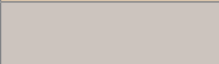
### SIGILLANTI COORDINATI PER FUGHE / COORDINATED GROUT SEALANTS

ZANZIBAR	COLORE SIGILLANTE SEALANT COLOUR	CODICE SIGILLANTE SEALANT CODE
Zanzibar sabbia chiaro - scuro		SI129B kromos bahama beige
Zanzibar grigio chiaro		SI120B kromos grigio luce
Zanzibar grigio scuro		SI121B kromos cemento

### COLLANTI / ADHESIVES

	
Bauflex Bianco AD200M Bauflex Grigio AD210M	Baurapid Grigio AD240M

Per una migliore resa estetica e tecnica ABK consiglia l'utilizzo di sigillanti e collanti HARDKOLL come da tabella. Per listino, scheda tecnica e approfondimenti vedi pag. 370  
 ABK suggests Hardkoll sealants and adhesives for a better aesthetics and technical efficiency, as follow. Read more at page 370 for prices and technical data sheets.



out .20

**GRES PORCELLANATO 20 MM**

out .20

**PORCELAIN STONEWARE 20 MM**

UNIKA	290
RE-WORK	292
DOLPHIN	294
SOLERAS	296

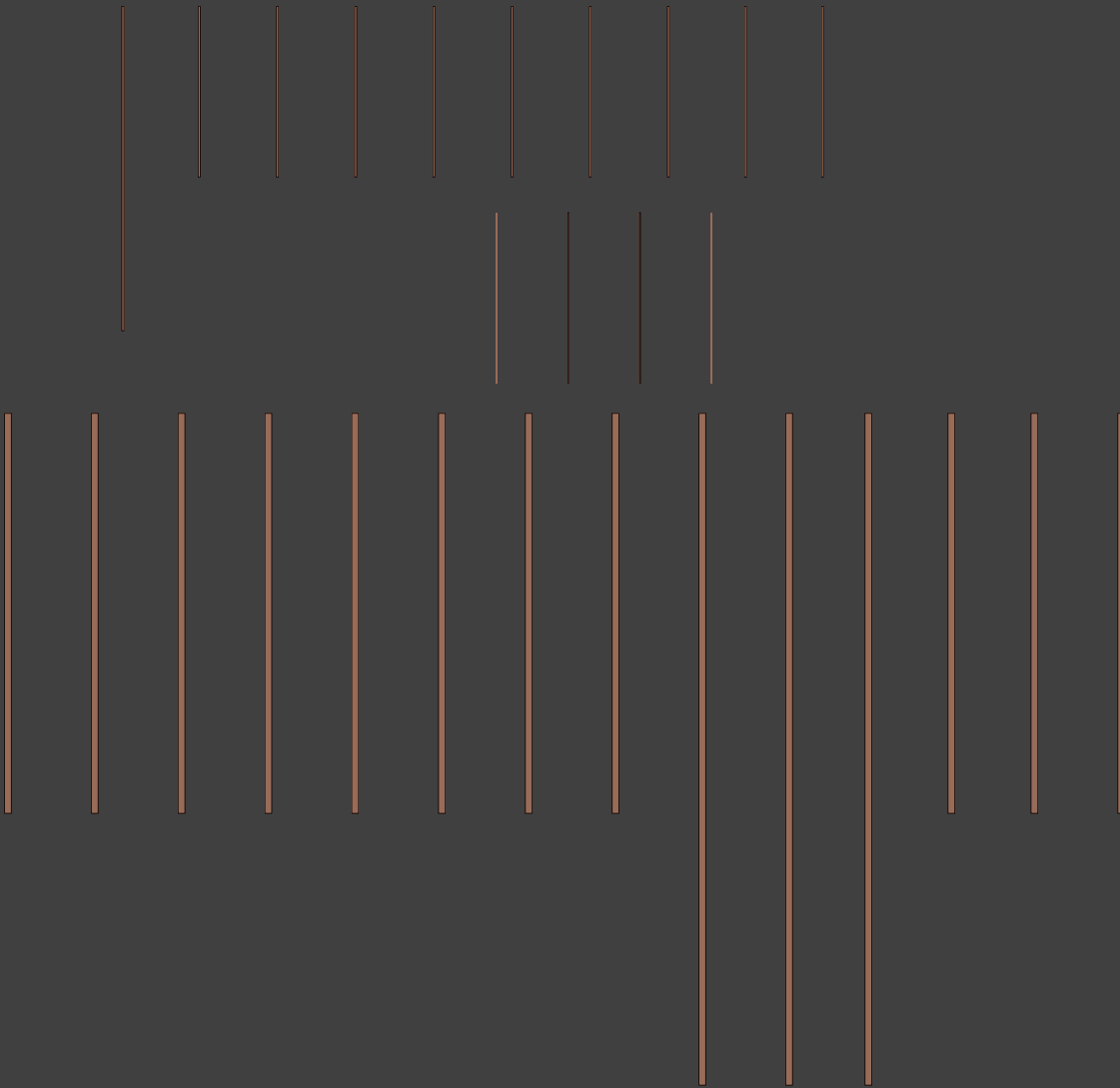

# OUT.20

## GRES PORCELLANATO A MASSA COLORATA

FULL BODY COLORED PORCELAIN STONEWARE

20 mm



40x80 2  
UNIKA ECRU 20 R11  
**UKN51100** bocc. nat. F 91,90



40x80 2  
UNIKA GREY 20 R11  
**UKN51150** bocc. nat. F 91,90



40x80 2  
UNIKA SMOKE 20 R11  
**UKN51200** bocc. nat. F 91,90

### PEZZI SPECIALI / SPECIAL TRIMS

		ECRU 20mm	GREY 20mm	SMOKE 20mm
	ELEMENTO L 20x40x5 PZ 62,90  2	<b>UKN51101</b>	<b>UKN51151</b>	<b>UKN51201</b>
	GRIGLIA 20x80 PZ 219,90  1	<b>UKN51102</b>	<b>UKN51152</b>	<b>UKN51202</b>
	ANG. GRIGLIA SX 20x80 PZ 299,90  1	<b>UKN51103</b>	<b>UKN51153</b>	<b>UKN51203</b>
	ANG. GRIGLIA DX 20x80 PZ 299,90  1	<b>UKN51104</b>	<b>UKN51154</b>	<b>UKN51204</b>

### IMBALLI/PACKAGING

F.to nominale Nominal size	F.to reale (mm) Real size (mm)	Spessore Thickness	Pz/Scatola Pcs/Box	Mq/Scatola Sqm/Box	Kg/Scatola Kg/Box	Scatole/Imballo Box/Packing	Mq totali Sqm total	Kg totali Kg total
40x80 / 16"x32" nat.	-	20 mm	2	0,64	28,26	24	15,36	698

L'unità minima di vendita per tutti gli articoli (fondi, decori e pezzi speciali) è la scatola completa. / The minimum sales quantity for all items (plain tiles, decorations and special trims) is one full box.

290

I dati relativi agli imballi sono aggiornati al momento della stampa del catalogo e pertanto possono subire variazioni nel corso del tempo. / Data referring to packaging have been update at time of printing; the actual data may be slightly different.

Pezzi speciali e decori per effetto delle lavorazioni, possono presentare variazioni di tonalità. / Due to working process special trims and decors, may show variation in tonality.



floor. Unika smoke 20mm 40x80

*the spoon* food & wine



# OUT.20

## GRES PORCELLANATO A MASSA COLORATA

FULL BODY COLORED PORCELAIN STONEWARE

20 mm



40x80 2  
RE-WORK MULTI FOG 20   
**REN51400** nat. F 91,90

40x80 2  
RE-WORK MULTI BEIGE 20   
**REN51350** nat. F 91,90

### PEZZI SPECIALI / SPECIAL TRIMS

		MULTI FOG 20mm	MULTI BEIGE 20mm
	ELEMENTO L 20x40x5 PZ 62,90  2	<b>REN51401</b>	<b>REN51351</b>
	GRIGLIA 20x80 PZ 219,90  1	<b>REN51402</b>	<b>REN51352</b>
	ANG. GRIGLIA SX 20x80 PZ 299,90  1	<b>REN51403</b>	<b>REN51353</b>
	ANG. GRIGLIA DX 20x80 PZ 299,90  1	<b>REN51404</b>	<b>REN51354</b>

### IMBALLI/PACKAGING

F.to nominale Nominal size	F.to reale (mm) Real size (mm)	Spessore Thickness	Pz/Scatola Pcs/Box	Mq/Scatola Sqm/Box	Kg/Scatola Kg/Box	Scatole/Imballo Box/Packing	Mq totali Sqm total	Kg totali Kg total
40x80 / 16"x32" nat.	-	20 mm	2	0,64	28,26	24	15,36	698

L'unità minima di vendita per tutti gli articoli (fondi, decori e pezzi speciali) è la scatola completa. / The minimum sales quantity for all items (plain tiles, decorations and special trims) is one full box.

I dati relativi agli imballi sono aggiornati al momento della stampa del catalogo e pertanto possono subire variazioni nel corso del tempo. / Data referring to packaging have been update at time of printing; the actual data may be slightly different.

292 Pezzi speciali e decori per effetto delle lavorazioni, possono presentare variazioni di tonalità. / Due to working process special trims and decors, may show variation in tonality.



floor. Multi Fog 20 mm 40x80





# OUT.20

## GRES PORCELLANATO A MASSA COLORATA

FULL BODY COLORED PORCELAIN STONEWARE

20 mm



30x120 2  
DOLPHIN CLAY 20   
DPR57100 rett. F 101,90

30x120 2  
DOLPHIN OAK 20   
DPR57150 rett. F 101,90

30x120 2  
DOLPHIN GREY 20   
DPR57250 rett. F 101,90

### PEZZI SPECIALI / SPECIAL TRIMS

		CLAY 20mm	OAK 20mm	GREY 20mm
	ELEMENTO L 15x60x5 PZ 88,90  2	DPR57101	DPR57151	DPR57251
	GRIGLIA 15x60 PZ 168,90  4	DPR57102	DPR57152	DPR57252
	ANG. GRIGLIA SX 15x60 PZ 228,90  4	DPR57103	DPR57153	DPR57253
	ANG. GRIGLIA DX 15x60 PZ 228,90  4	DPR57104	DPR57154	DPR57254

### IMBALLI/PACKAGING

F.to nominale Nominal size	F.to reale (mm) Real size (mm)	Spessore Thickness	Pz/Scatola Pcs/Box	Mq/Scatola Sqm/Box	Kg/Scatola Kg/Box	Scatole/Imballo Box/Packing	Mq totali Sqm total	Kg totali Kg total
30x120 / 12"x48" rett	295x1200	20 mm	2	0,72	32,90	30	21,60	1030

L'unità minima di vendita per tutti gli articoli (fondi, decori e pezzi speciali) è la scatola completa. / The minimum sales quantity for all items (plain tiles, decorations and special trims) is one full box.

I dati relativi agli imballi sono aggiornati al momento della stampa del catalogo e pertanto possono subire variazioni nel corso del tempo. / Data referring to packaging have been update at time of printing; the actual data may be slightly different.

Pezzi speciali e decori per effetto delle lavorazioni, possono presentare variazioni di tonalità. / Due to working process special trims and decors, may show variation in tonality.

floor. Dolphin Grey 20mm rett. 30x120



# OUT.20

## GRES PORCELLANATO A MASSA COLORATA

FULL BODY COLORED PORCELAIN STONEWARE

20 mm



30x120 2  
**SOLERAS NATURALE 20**  
**S1R57200** rett. R11  
 F 101,90

30x120 2  
**SOLERAS AVANA 20**  
**S1R57250** rett. R11  
 F 101,90

### PEZZI SPECIALI / SPECIAL TRIMS

		NATURALE 20mm	AVANA 20mm
	ELEMENTO L 15x60x5 PZ 88,90  2	<b>S1R57201</b>	<b>S1R57251</b>
	GRIGLIA 15x60 PZ 168,90  4	<b>S1R57202</b>	<b>S1R57252</b>
	ANG. GRIGLIA SX 15x60 PZ 228,90  4	<b>S1R57203</b>	<b>S1R57253</b>
	ANG. GRIGLIA DX 15x60 PZ 228,90  4	<b>S1R57204</b>	<b>S1R57254</b>

### IMBALLI/PACKAGING

F.to nominale Nominal size	F.to reale (mm) Real size (mm)	Spessore Thickness	Pz/Scatola Pcs/Box	Mq/Scatola Sqm/Box	Kg/Scatola Kg/Box	Scatole/Imballo Box/Packing	Mq totali Sqm total	Kg totali Kg total
30x120 / 12"x48" rett	295x1200	20 mm	2	0,72	32,90	30	21,60	1030

L'unità minima di vendita per tutti gli articoli (fondi, decori e pezzi speciali) è la scatola completa. / The minimum sales quantity for all items (plain tiles, decorations and special trims) is one full box.  
 I dati relativi agli imballi sono aggiornati al momento della stampa del catalogo e pertanto possono subire variazioni nel corso del tempo. / Data referring to packaging have been update at time of printing; the actual data may be slightly different.  
 Pezzi speciali e decori per effetto delle lavorazioni, possono presentare variazioni di tonalità. / Due to working process special trims and decors, may show variation in tonality.



floor. Soleras Avana 20mm rett. 30x120





W & P

**PASTA BIANCA DA RIVESTIMENTO**

W & P

**WHITE BODY WALL TILE**

DO UP

300

DO UP TOUCH

310

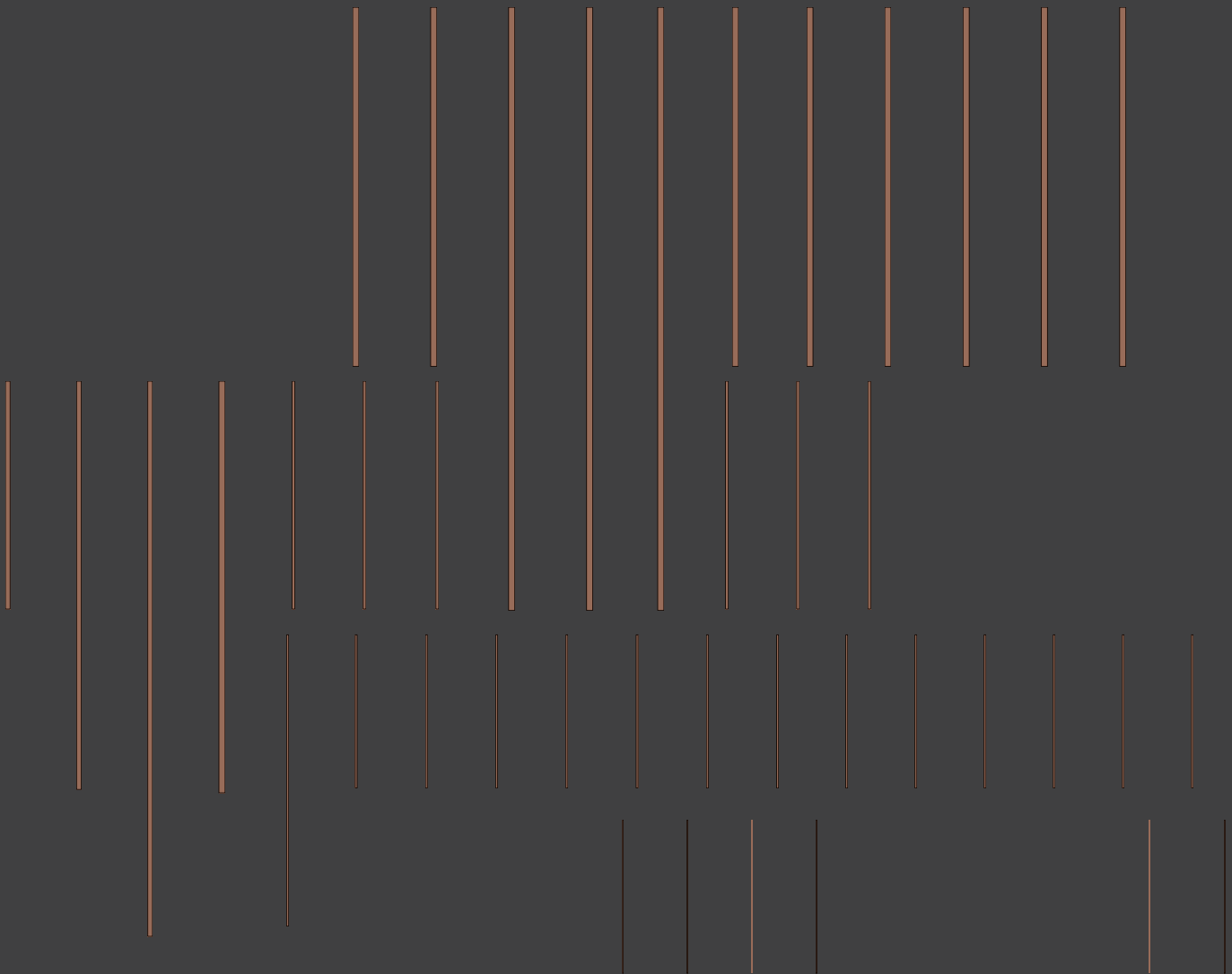



W&P™

## PASTA BIANCA DA RIVESTIMENTO

WHITE BODY WALL TILES

## SUPERFICI SURFACES

naturale - natural

## FORMATI SIZES



60x120  
24"x 48"



30x120  
12"x 48"



7 mm



COVER  
NEUTRAL

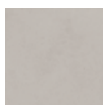

COVER  
TORTORA



COVER  
SABBIA

---

Classificazione secondo norme UNI EN 14411 (ISO 13006) Gruppo B1b  
Classification in accordance with UNI EN 14411 (ISO 13006) Group B1b



wall. Affresco light rett. 30x120 - Affresco dark rett. 30x120 - 60x120 - Cover tortora rett. 30x120 floor. INTERNO 9 pearl rett. 60x120



# Do up

wall. Memory Sabbia rett. 60x120 - Cover Sabbia rett. 60x120 - Alzata Gesso 12,5x120 - Punto Luce Gesso 12,5x120 **floor.** Dolphin Oak rett. 20x120





wall. Reverse Sky rett. 60x120 - Cover Tortora rett. 60x120 floor. INTERNO 9 Pearl rett. 60x120



# Do up

COVER

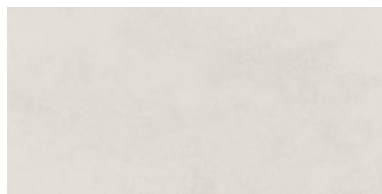

60x120  2  
**DOR3407A** COVER NEUTRAL rett. F 68,90

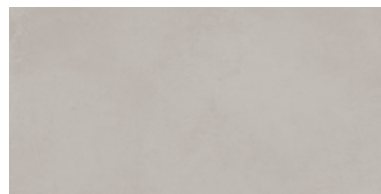

60x120  2  
**DOR3442A** COVER TORTORA rett. F 68,90

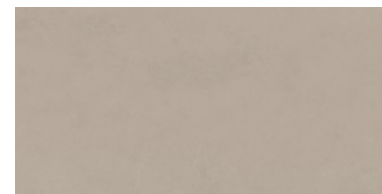

60x120  2  
**DOR3447A** COVER SABBIA rett. F 68,90

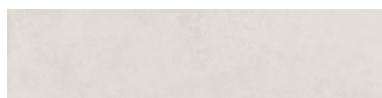

30x120  4  
**DOR5707O** COVER NEUTRAL rett. F 68,90

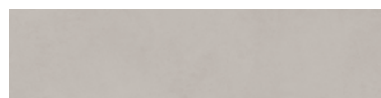

30x120  4  
**DOR5742O** COVER TORTORA rett. F 68,90

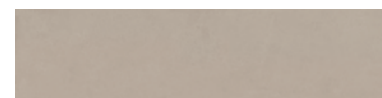

30x120  4  
**DOR5747O** COVER SABBIA rett. F 68,90



30x30  4  
**DOR34085** MOS. MINI  
 COVER NEUTRAL F 252,90



30x30  4  
**DOR34425** MOS. MINI  
 COVER TORTORA F 252,90



30x30  4  
**DOR34475** MOS. MINI  
 COVER SABBIA F 252,90



12,5x120  2  
**DOR34071** ALZATA GESSO rett. PZ 98,90



12,5x120  2  
**\*DOR34072** PUNTO LUCE GESSO rett. PZ 148,90

\* Articolo predisposto per il contenimento di una fonte luminosa a scomparsa, per un effetto di luce diffusa verso l'alto.

\* Item designed to contain a retractable light source, for an upward diffused light effect.





120x240 ☞ 1 cp = 2 box

**DOR34073** PROG. COVER PZ 1.398,90  
GEISHA 4 PZ. (prezzo a cp.)



60x120 ☞ 1

**DOR34079** DEC. COVER PZ 298,90  
GEISHA



120x240 ☞ 1 cp = 2 box

**DOR34074** PROG. COVER PZ 1.398,90  
LOVE 4 PZ. (prezzo a cp.)

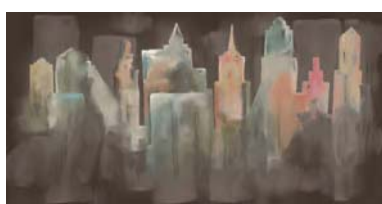

60x120 ☞ 1

**DOR34082** DEC. COVER CITY PZ 298,90

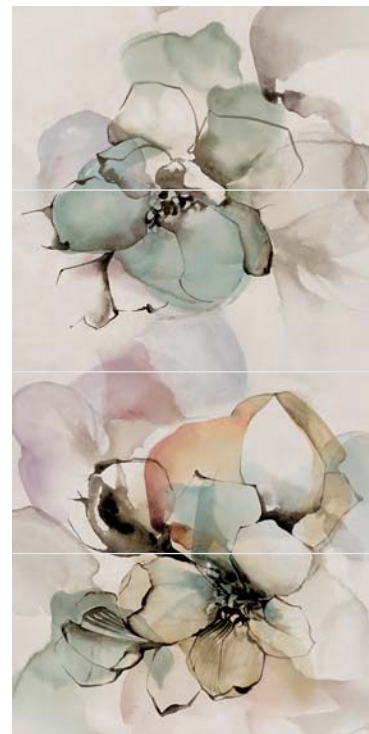

120x240 ☞ 1 cp = 2 box

**DOR34086** PROG. COVER PZ 1.398,90  
SPRING 4 PZ. (prezzo a cp.)



60x120 ☞ 1

**DOR34080** DEC. COVER PZ 298,90  
SPRING



# Do up

MEMORY



60x120 ☞ 2

\* **DOR3452A** MEMORY SABBIA rett. F 81,90



60x120 ☞ 2

\* **DOR3457A** MEMORY RUST rett. F 81,90

REVERSE



60x120 ☞ 2

\* **DOR3412A** REVERSE EARTH rett. F 81,90



60x120 ☞ 2

\* **DOR3417A** REVERSE SKY rett. F 81,90

SCRATCH



30x120 ☞ 4

\* **DOR57620** SCRATCH rett. F 81,90

\* La non perfetta continuità di linee, rilievi o motivi grafici tra piastrelle adiacenti è naturale conseguenza del processo produttivo, pertanto non costituisce un vizio del prodotto.

Any variations in graphic designs or textures between adjacent tiles are a natural consequence of the manufacturing process and do not constitute a product defect.



AFFRESCO



60x120  2

\* **DOR34720** AFFRESCO DARK rett. F 81,90



30x120  4

\* **DOR57720** AFFRESCO DARK rett. F 81,90



60x120  2

\* **DOR34670** AFFRESCO LIGHT rett. F 81,90



30x120  4

\* **DOR57670** AFFRESCO LIGHT rett. F 81,90





# Do up

STREET



60x120 ☞ 2

\* **DOR34220** STREET WHITE MATT rett. F 81,90



60x120 ☞ 2

\* **DOR34320** STREET BLACK MATT rett. F 81,90



60x120 ☞ 1

\* **DOR34221** DEC. STREET KID-BELIEVE MATT PZ 298,90



\* 60x120 ☞ 2

\*\* **DOR34230** DEC. STREET CLASS BLACK MIX2 PZ 328,90 (prezzo al pz.)



60x120 ☞ 1

\* **DOR34222** DEC. STREET KID-NEXT MATT PZ 298,90

\*\* Articoli realizzati con metalli preziosi; si consiglia di pulire la superficie senza utilizzare prodotti contenenti sostanze abrasive.  
Items produced with precious metals; do not use products containing abrasive substances to clean the surface.



60x120 ☞ 1

\* **DOR34223** DEC. STREET KID-WHY MATT PZ 298,90

\* La non perfetta continuità di linee, rilievi o motivi grafici tra piastrelle adiacenti è naturale conseguenza del processo produttivo, pertanto non costituisce un vizio del prodotto.

Any variations in graphic designs or textures between adjacent tiles are a natural consequence of the manufacturing process and do not constitute a product defect.







60x120  2

\* **DOR34270** STREET WHITE rett. F 81,90  
GLOSSY



120x240  1 cp = 2 box

\* **DOR34224** PROG. STREET MISS YOU GLOSSY 4 PZ. PZ 1.398,90  
(prezzo a cp.)



120x240  1 cp = 2 box

\* **DOR34225** PROG. STREET MAXI COLORS GLOSSY 4 PZ. PZ 1.398,90  
(prezzo a cp.)

## IMBALLI/PACKAGING



F.to nominale Nominal size	F.to reale (mm) Real size (mm)	Spessore Thickness	Pz/Scatola Pcs/Box	Mq/Scatola Sqm/Box	Kg/Scatola Kg/Box	Scatole/Imballo Box/Packing	Mq totali Sqm total	Kg totali Kg total
60x120 / 24"x48" rett.	596x1194	7 mm	2	1,44	23,00	26	37,44	640
60x120 / 24"x48" rett. STREET	596x1194	7 mm	2	1,44	28,30	24	34,56	712
30x120 / 12"x48" rett.	297x1194	7 mm	4	1,44	23,00	20	28,80	480

L'unità minima di vendita per tutti gli articoli (fondi, decori e pezzi speciali) è la scatola completa. / The minimum sales quantity for all items (plain tiles, decorations and special trims) is one full box.

I dati relativi agli imballi sono aggiornati al momento della stampa del catalogo e pertanto possono subire variazioni nel corso del tempo. / Data referring to packaging have been update at time of printing; the actual data may be slightly different.

Pezzi speciali e decori per effetto delle lavorazioni, possono presentare variazioni di tonalità. / Due to working process special trims and decors, may show variation in tonality.

Pezzi speciali e decori per effetto delle lavorazioni, possono presentare variazioni di tonalità. / Due to working process special trims and decors, may show variation in tonality.

	SIGILLANTI COORDINATI PER FUGHE / COORDINATED GROUT SEALANTS		COLLANTI / ADHESIVES		
	DO UP	COLORE SIGILLANTE SEALANT COLOUR	CODICE SIGILLANTE SEALANT CODE		
	Tortora - Sabbia		SI123B kromos manhattan		
	Neutral		SI120B kromos grigio luce		
				Baulite S2 Bianco AD340M	+30 Bianco AD330M
				Baulite S2 Grigio AD341M	+30 Grigio AD331M

Per una migliore resa estetica e tecnica ABK consiglia l'utilizzo di sigillanti e collanti HARDKOLL come da tabella. Per listino, scheda tecnica e approfondimenti vedi pag. 370  
ABK suggests Hardkoll sealants and adhesives for a better aesthetics and technical efficiency, as follow. Read more at page 370 for prices and technical data sheets.

# Do up touch

---

W&P™

## PASTA BIANCA DA RIVESTIMENTO

WHITE BODY WALL TILES

## SUPERFICI SURFACES

naturale - natural

## FORMATI SIZES



60x120  
24"x 48"



30x120  
12"x 48"



7 mm

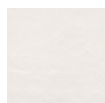

BASE WHITE

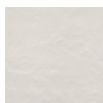

BASE GREY



BASE IVORY

---

Classificazione secondo norme UNI EN 14411 (ISO 13006) Gruppo B1b  
Classification in accordance with UNI EN 14411 (ISO 13006) Group B1b



wall. Base White Matt 60x120 - Feel White Matt 30x120 - Mos. Dynamic White Glossy 30x30 - Dolphin Grey 20x120 floor. Dolphin Grey 20x120 + 20x170





# Do up touch

wall. Feel Ivory matt 30x120



wall. Soft Ivory Matt 30x120 - Feel Ivory Matt 30x120 - Sensi Sahara Cream Sable' 30x120 - Dolphin Clay 20x120 (piano lavabo/counter top) floor. Dolphin Clay 20x120



# Do up touch

## BASE



White



60x120  2  
BASE WHITE  
**3DR34050** matt rett. F 68,90



30x120  4  
BASE WHITE  
**3DR57050** matt rett. F 68,90

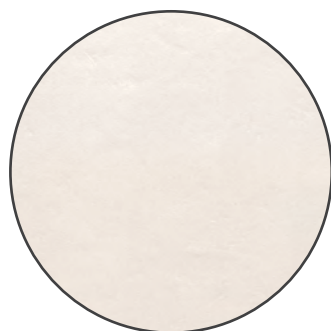

Ivory

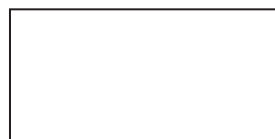

60x120  2  
BASE IVORY  
**3DR34150** matt rett. F 68,90



30x120  4  
BASE IVORY  
**3DR57150** matt rett. F 68,90



Grey

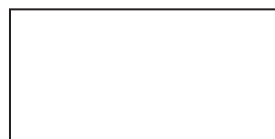

60x120  2  
BASE GREY  
**3DR34100** matt rett. F 68,90



30x120  4  
BASE GREY  
**3DR57100** matt rett. F 68,90

## SOFT



White



30x120  4  
SOFT WHITE  
**3DR57200** matt rett. F 81,90

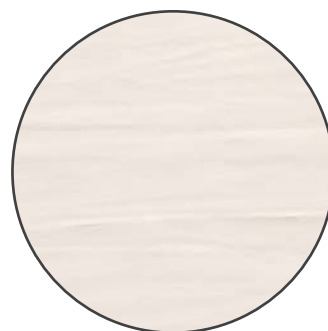

Ivory



30x120  4  
SOFT IVORY  
**3DR57250** matt rett. F 81,90

La non perfetta continuità di linee, rilievi o motivi grafici tra piastrelle adiacenti è naturale conseguenza del processo produttivo, pertanto non costituisce un vizio del prodotto.

Any variations in graphic designs or textures between adjacent tiles are a natural consequence of the manufacturing process and do not constitute a product defect.



## PLISSE'



White

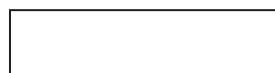

30x120  4  
PLISSÉ WHITE  
**3DR57300** matt rett. F 81,90  
**3DR57350** glossy rett. F 81,90



Ivory



30x120  4  
PLISSÉ IVORY  
**3DR57400** matt rett. F 81,90

## FEEL



White

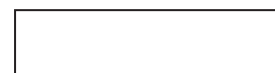

30x120  4  
FEEL WHITE  
**3DR57450** matt rett. F 81,90  
**3DR57500** glossy rett. F 81,90



Ivory



30x120  4  
FEEL IVORY  
**3DR57550** matt rett. F 81,90



Antracite



30x120  4  
FEEL ANTRACITE  
**3DR57600** matt rett. F 81,90

# Do up touch

## Mos. Dynamic



30x30  4  
MOS. DYNAMIC WHITE  
**3DR57451** matt rett. F 169,90



30x30  4  
MOS. DYNAMIC WHITE  
**3DR57501** glossy rett. F 169,90



30x30  4  
MOS. DYNAMIC IVORY  
**3DR57551** matt rett. F 169,90

## Brick



7,5x30  20  
BRICK MIX 4 WHITE  
**3DR34060** matt rett. F 109,90



7,5x30  20  
BRICK MIX 4 IVORY  
**3DR34160** matt rett. F 109,90



7,5x30  20  
BRICK FEEL ANTRACITE  
**3DR34610** matt rett. F 109,90

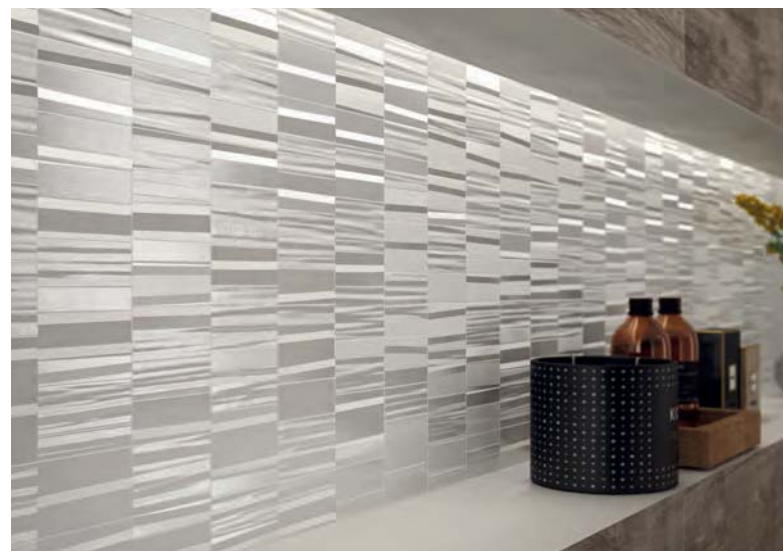



## IMBALLI/PACKAGING

F.to nominale Nominal size	F.to reale (mm) Real size (mm)	Spessore Thickness	Pz/Scatola Pcs/Box	Mq/Scatola Sqm/Box	Kg/Scatola Kg/Box	Scatole/Imballo Box/Packing	Mq totali Sqm total	Kg totali Kg total
60x120 / 24"x48" rett.	596x1194	7 mm	2	1,44	23,00	26	34,77	640
30x120 / 12"x48" rett.	297x1194	7 mm	4	1,44	23,00	20	28,80	480
30x120 / 12"x48" rett. FEEL PLISSÉ	297x1194	7 mm	4	1,44	23,00	18	25,92	430
7,5x30 / 3,1"x12" rett.	-	7 mm	20	0,45	7,20	-	-	-

L'unità minima di vendita per tutti gli articoli (fondi, decori e pezzi speciali) è la scatola completa. / The minimum sales quantity for all items (plain tiles, decorations and special trims) is one full box. / I dati relativi agli imballi sono aggiornati al momento della stampa del catalogo e pertanto possono subire variazioni nel corso del tempo. / Data referring to packaging have been update at time of printing; the actual data may be slightly different. / Pezzi speciali e decori per effetto delle lavorazioni, possono presentare variazioni di tonalità. / Due to working process special trims and decors, may show variation in tonality.

Base ivory matt 30x120 - Plissé ivory matt 30x120 - Dolphin oak 20x120

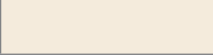
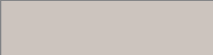

SIGILLANTI COORDINATI PER FUGHE / COORDINATED GROUT SEALANTS			COLLANTI / ADHESIVES	
DO UP TOUCH	COLORE SIGILLANTE SEALANT COLOUR	CODICE SIGILLANTE SEALANT CODE		
White		SI124B kromos bianco	Baulite S2 Bianco AD340M	+30 Bianco AD330M
Ivory		SI126B kromos avorio	Baulite S2 Grigio AD341M	+30 Grigio AD331M
Grey		SI120B kromos grigio luce		

Per una migliore resa estetica e tecnica ABK consiglia l'utilizzo di sigillanti e collanti HARDKOLL come da tabella. Per listino, scheda tecnica e approfondimenti vedi pag. 370  
 ABK suggests Hardkoll sealants and adhesives for a better aesthetics and technical efficiency, as follow. Read more at page 370 for prices and technical data sheets.



# rivestimenti contemporanei

**CONTEMPORARY WALL TILES**

PAPIER	320
SECRET	328
GRACE	336
TRACKS	348
AQUA	354
VISION	360
ZANZIBAR	366

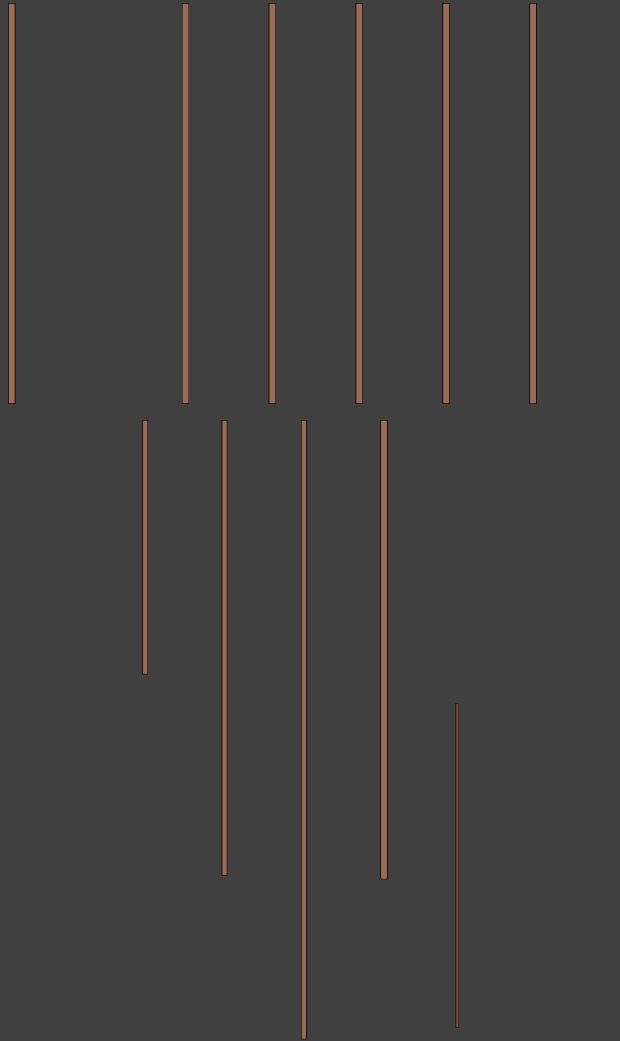

# Papier

---

## BICOTTURA IN PASTA BIANCA

DOUBLE-FIRED WHITE BODY TILES

## SUPERFICI SURFACES

naturale - natural

## FORMATI SIZES



30x75  
12"x 30"



60x60  
24"x 24"

Pavimento coordinato in gres porcellanato  
Coordinating porcelain floor tiles (pag. 96)

▼  
9 mm  
▲



COTONE



CORDA



NOCCIOLA



SALVIA



GRIGIO



ANTRACITE

---

Classificazione secondo norme UNI EN 14411 (ISO 13006) Gruppo BIII GL

Classification in accordance with UNI EN 14411 (ISO 13006) Group BIII GL





wall. Corda 30x75 - Progetto fleur 90x225 - Fascia legno 2,5x30 floor. Soleras naturale rett. 40x170



# Papier

Salvia 30x75 - Cotone 30x75 - dec. samarcanda Cotone - dec. samarcanda Salvia - list. samarcanda Topazio





wall. Grigio 30x75 - Antracite 30x75 - Comp. Lettering Grigio 120x75 floor. Antracite Rett. 60x60





# Papier



30x75  5  
PAPIER COTONE  
PPN53050 F 48,90



30x75  5  
PAPIER CORDA  
PPN53100 F 48,90



30x75  5  
PAPIER GRIGIO  
PPN53250 F 48,90



30x75  5  
PAPIER ANTRACITE  
PPN53300 F 48,90



30x75  2  
DEC. SAMARCANDA COTONE  
\* PPN53057 PZ 52,90

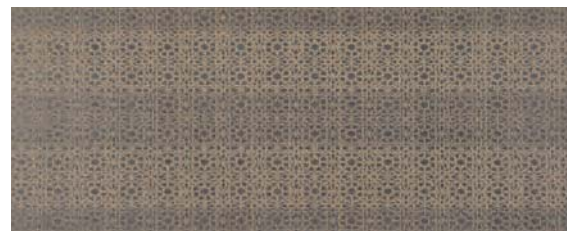

30x75  2  
DEC. SAMARCANDA ANTRACITE  
\* PPN53307 PZ 52,90



3x75  3  
LIST. SAMARCANDA BRONZO  
\* PPN53056 PZ 20,90



3x75  3  
LIST. SAMARCANDA BRONZO  
\* PPN53056 PZ 20,90

\* Articoli realizzati con metalli preziosi; si consiglia di pulire la superficie senza utilizzare prodotti contenenti sostanze abrasive.  
Items produced with precious metals; do not use products containing abrasive substances to clean the surface.



30x75  5  
PAPIER NOCCIOLA  
PPN53150 F 48,90



30x75  5  
PAPIER SALVIA  
PPN53200 F 48,90

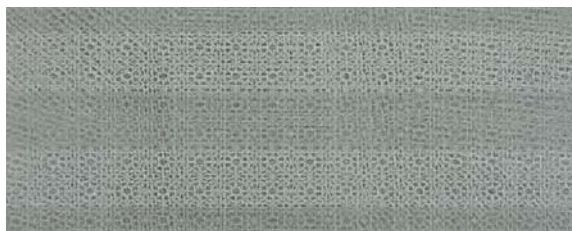

30x75  2  
DEC. SAMARCANDA SALVIA  
\* PPN53207 PZ 52,90



3x75  3  
LIST. SAMARCANDA TOPAZIO  
\* PPN53206 PZ 20,90

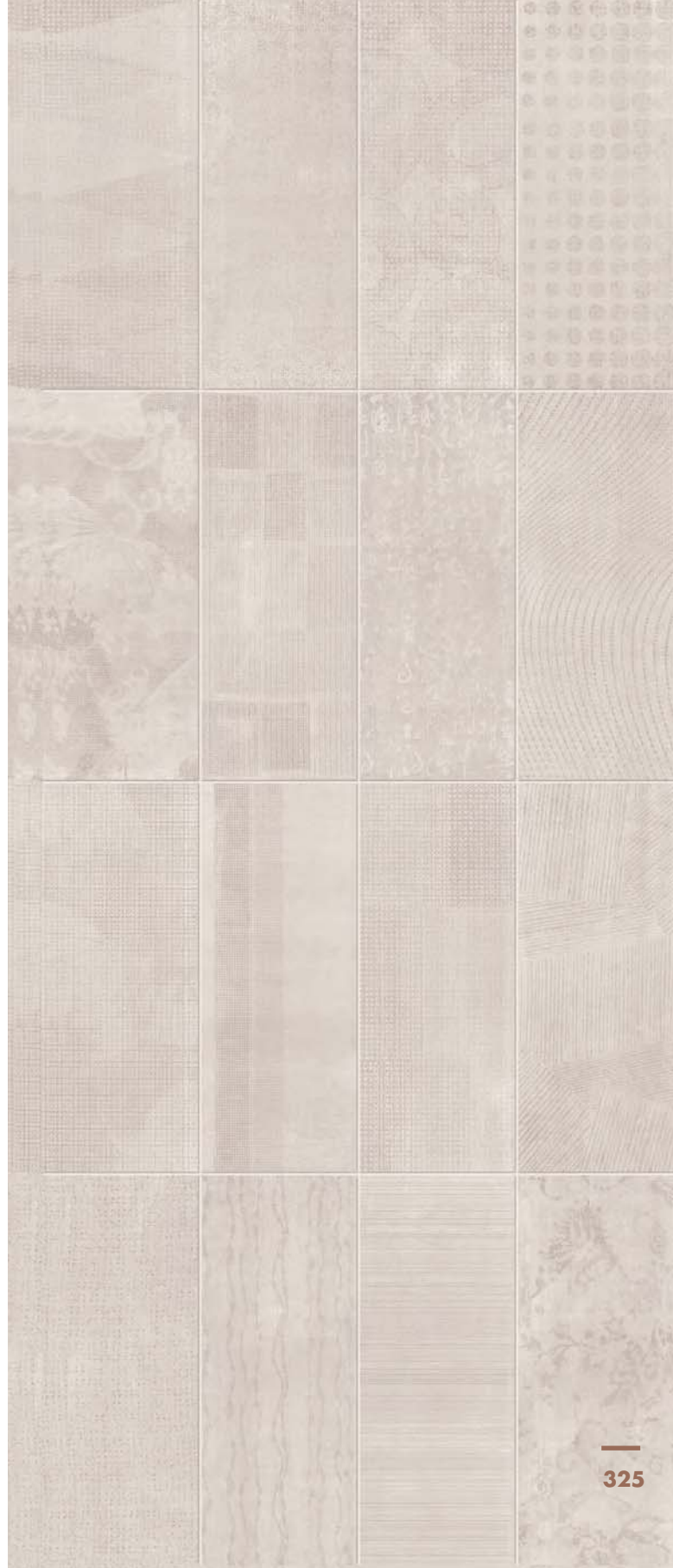

# Papier



90x225 1 cp = 3 box  
PROGETTO FLEUR CORDA (Comp. 9 pz.)  
PPN53101 PZ 749,90



75x120 1 cp  
COMP. LETTERING CORDA (4 pz.)  
PPN53105 PZ 229,90



2,5x30 4  
FASCIA LEGNO PAPIER  
\* PPN53058 PZ 12,90  
(Legno - Wood)

\* Art. realizzati con materiali naturali:  
vedi indicazioni per posa e pulizia a pag. 393 dell' area tecnica.  
Items produced with natural materials:  
check the technical area at page 393.



PAVIMENTI IN GRES PORCELLANATO / PORCELAIN FLOOR TILES

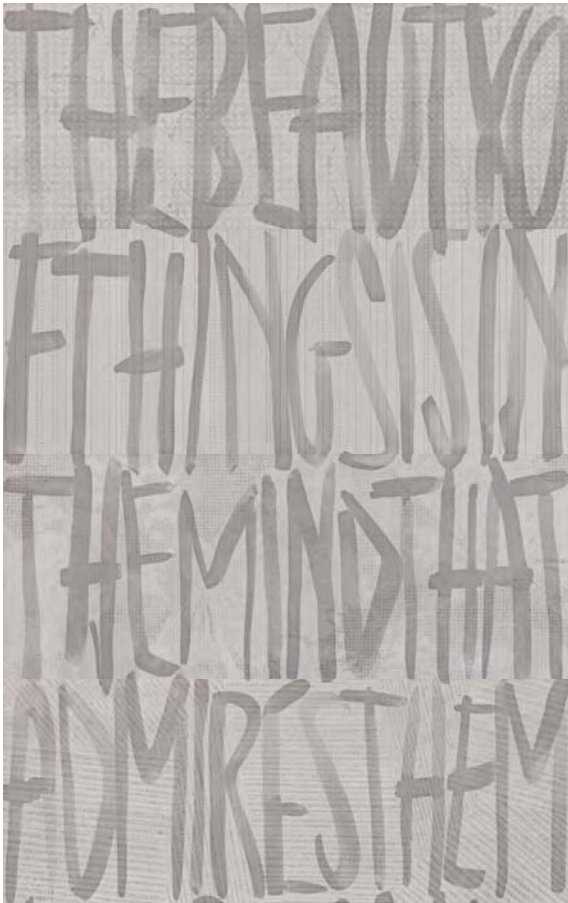

75x120  1 cp  
 COMP. LETTERING GRIGIO (4 PZ.)  
**PPN53255** PZ 229,90

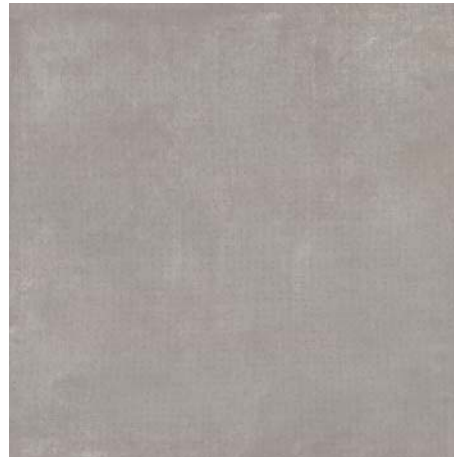

60x60  3  
 PAPIER GRIGIO  
**PPR01250** rett. F 53,90



60x60  3  
 PAPIER CORDA  
**PPR01100** rett. F 53,90

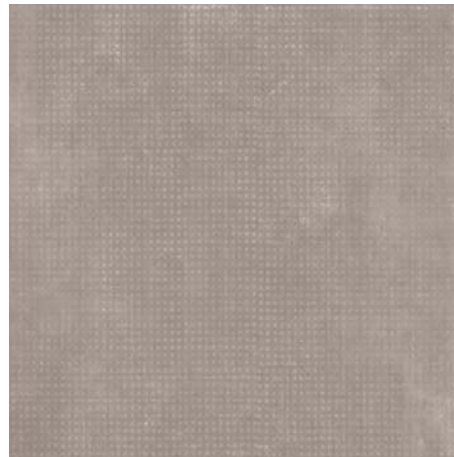

60x60  3  
 PAPIER NOCCIOLA  
**PPR01150** rett. F 53,90



60x60  3  
 PAPIER ANTRACITE  
**PPR01300** rett. F 53,90

Serie completa a pagina 96. / Complete collection page 96.

IMBALLI/PACKAGING

F.to nominale Nominal size	F.to reale (mm) Real size (mm)	Spessore Thickness	Pz/Scatola Pcs/Box	Mq/Scatola Sqm/Box	Kg/Scatola Kg/Box	Scatole/Imballo Box/Packing	Mq totali Sqm total	Kg totali Kg total
30x75 / 12"x30"	-	9 mm	5	1,13	17,60	36	40,68	654
60x60 / 24"x24"	-	9 mm	3	1,08	21,20	40	43,20	868

L'unità minima di vendita per tutti gli articoli (fondi, decori e pezzi speciali) è la scatola completa. / The minimum sales quantity for all items (plain tiles, decorations and special trims) is one full box.  
 I dati relativi agli imballi sono aggiornati al momento della stampa del catalogo e pertanto possono subire variazioni nel corso del tempo. / Data referring to packaging have been update at time of printing; the actual data may be slightly different.  
 Pezzi speciali e decori per effetto delle lavorazioni, possono presentare variazioni di tonalità. / Due to working process special trims and decors, may show variation in tonality.

# Secret

---

## BICOTTURA IN PASTA BIANCA

DOUBLE-FIRED WHITE BODY TILES

## SUPERFICI SURFACES

naturale - natural

## FORMATI SIZES



30x75  
12"x 30"



33,3x33,3  
13"x 13"

Pavimento coordinato in gres porcellanato  
Coordinating porcelain floor tiles

9 mm  
▲▼



SOLE

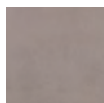

CAPPUCCINO

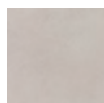

NATURAL



GESSO



TORTORA

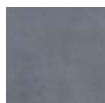

NOTTE

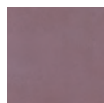

MALVA

---

Classificazione secondo norme UNI EN 14411 (ISO 13006) Gruppo BIII GL

Classification in accordance with UNI EN 14411 (ISO 13006) Group BIII GL



wall. Tortora 30x75 - Tortora opus 30x75 - Notte 30x75 - Mos. mini gesso 30x30 - Dec. opus notte 30x75 - Fascia micro argento 2x30 floor. Docks grey rett. 60x60





# Secret

**wall.** Gesso 30x75 - Cappuccino 30x75 - Gesso Opus 30x75 - Dec. Opus Cappuccino 30x75 - Fascia Micro Argento 2x30

**floor.** Docks Silver rett. 60x60 - Mos. Quadretti Silver 30x30



wall. Gesso 30x75 - Natural 30x75 - Mosaico Mini Gesso 30x30 - Progetto Female 90x225 floor. Soleras Grigio Rett. 20x80 - 13,5x80



# Secret



30x75  5  
SECRET GESSO  
**SCT050** F 48,90



30x75  5  
SECRET TORTORA  
**SCT250** F 48,90



3x30  4  
LONDON TORTORA  
**SCT252** PZ 13,90



3x3  2  
ANG. LONDON TORTORA  
**SCT253** PZ 13,90

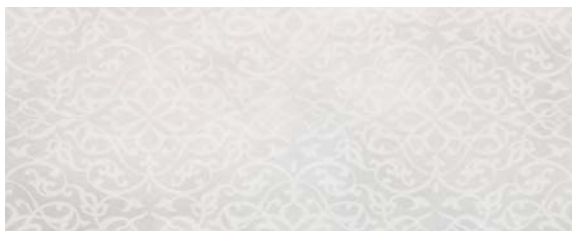

30x75  5  
SECRET GESSO OPUS  
**SCT051** F 53,90



30x75  5  
SECRET TORTORA OPUS  
**SCT251** F 53,90



30x75  2  
DEC. LUXURY PERLA  
**SCT063** PZ 49,90

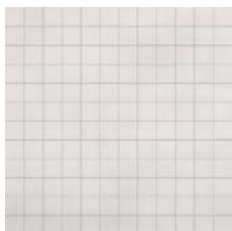

30x30  4  
MOSAICO MINI GESSO  
**SCT069** PZ 20,90

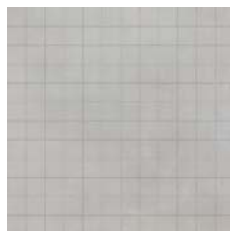

30x30  4  
MOSAICO MINI TORTORA  
**SCT269** PZ 20,90

Pavimento coordinato in gres porcellanato  
Coordinating porcelain floor tiles



33,3x33,3  11  
SECRET TORTORA  
**SCT2500** F 48,90





30x75  5  
SECRET NATURAL  
**SCT100** F 48,90



3x30  4  
LONDON NATURAL  
**SCT102** PZ 13,90



3x3  2  
ANG. LONDON NATURAL  
**SCT103** PZ 13,90

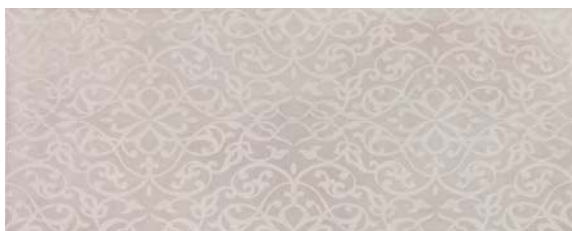

30x75  5  
SECRET NATURAL OPUS  
**SCT101** F 53,90



30x75  2  
DEC. LUXURY BEIGE  
**SCT062** PZ 49,90

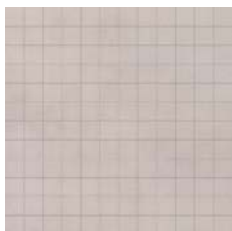

30x30  4  
MOSAICO MINI NATURAL  
**SCT119** PZ 20,90

Pavimento coordinato in gres porcellanato  
Coordinating porcelain floor tiles



33,3x33,3  11  
SECRET NATURAL  
**SCT1000** F 48,90



90x225  1 cp = 3 box  
PROGETTO FEMALE  
**SCT052** PZ 749,90  
(prezzo a cp.)

# Secret

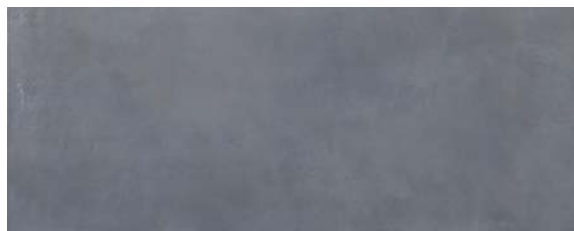

30x75  5  
SECRET NOTTE  
**SCT300** F 48,90



30x75  5  
SECRET MALVA  
**SCT350** F 48,90



30x75  2  
DEC. OPUS NOTTE  
**\*SCT301** PZ 49,90



30x75  2  
DEC. OPUS MALVA  
**\*SCT351** PZ 49,90



30x75  2  
DEC. REMAKE FLOWER NOTTE  
**SCT055** PZ 54,90



30x75  2  
DEC. REMAKE FLOWER MALVA  
**SCT053** PZ 54,90

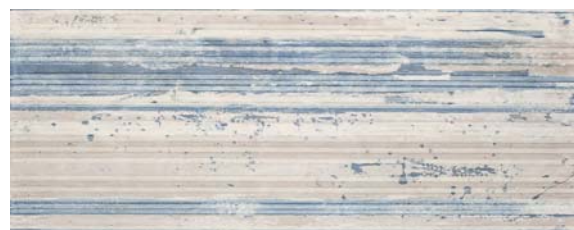

30x75  2  
DEC. REMAKE STRIPES NOTTE  
**SCT056** PZ 54,90

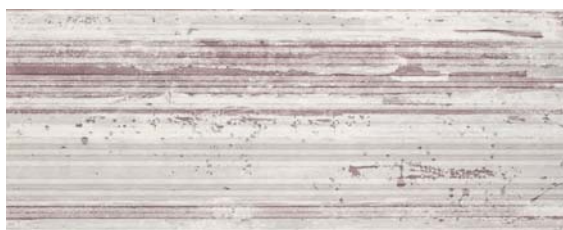

30x75  2  
DEC. REMAKE STRIPES MALVA  
**SCT054** PZ 54,90

Pavimento coordinato in gres porcellanato  
Coordinating porcelain floor tiles

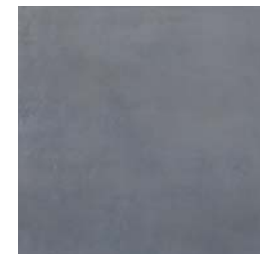

33,3x33,3  11  
SECRET NOTTE  
**SCT3000** F 48,90



33,3x33,3  11  
SECRET MALVA  
**SCT3500** F 48,90

\* Articoli realizzati con metalli preziosi; si consiglia di pulire la superficie senza utilizzare prodotti contenenti sostanze abrasive.  
Items produced with precious metals; do not use products containing abrasive substances to clean the surface.



30x75  5  
SECRET CAPPUCCINO  
**SCT200** F 48,90

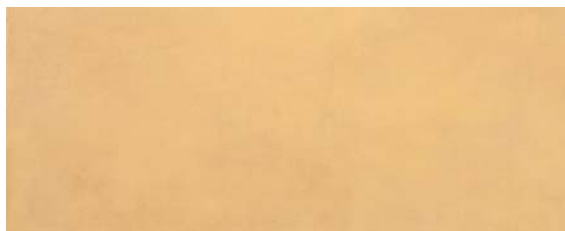

30x75  5  
SECRET SOLE  
**SCT150** F 48,90

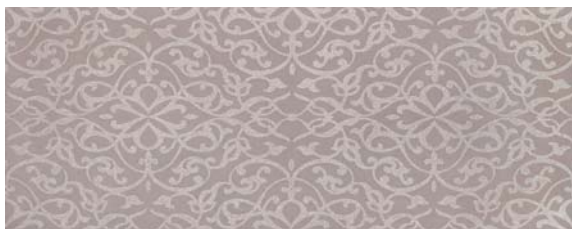

30x75  2  
DEC. OPUS CAPPUCCINO  
\* **SCT201** PZ 49,90



15x75  2  
LIST. ESTATE SOLE MIX 2  
**SCT060** PZ 39,90  
(prezzo cad.)



30x75  3  
DEC. ORIENTE MIX 3  
**SCT061** PZ 54,90  
(prezzo cad.)



2x30  4  
FASCIA MICRO ARGENTO  
\* **SCT067** PZ 13,90



2x30  4  
FASCIA MICRO ORO  
\* **SCT066** PZ 13,90

Pavimento coordinato in gres porcellanato  
Coordinating porcelain floor tiles

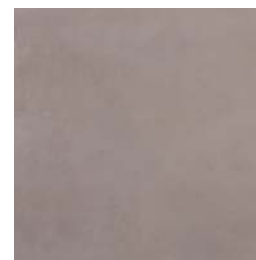

33,3x33,3  11  
SECRET CAPPUCCINO  
**SCT2000** F 48,90

#### IMBALLI/PACKAGING

F.to nominale Nominal size	F.to reale (mm) Real size (mm)	Spessore Thickness	Pz/Scatola Pcs/Box	Mq/Scatola Sqm/Box	Kg/Scatola Kg/Box	Scatole/Imballo Box/Packing	Mq totali Sqm total	Kg totali Kg total
30x75 / 12"x30"	-	9 mm	5	1,13	17,60	36	40,68	654
33,3x33,3 / 13"x13"	-	9 mm	11	1,22	24,00	44	53,68	1076

L'unità minima di vendita per tutti gli articoli (fondi, decori e pezzi speciali) è la scatola completa. / The minimum sales quantity for all items (plain tiles, decorations and special trims) is one full box.  
I dati relativi agli imballi sono aggiornati al momento della stampa del catalogo e pertanto possono subire variazioni nel corso del tempo. / Data referring to packaging have been update at time of printing; the actual data may be slightly different.  
Pezzi speciali e decori per effetto delle lavorazioni, possono presentare variazioni di tonalità. / Due to working process special trims and decors, may show variation in tonality.



# Grace

---

## BICOTTURA IN PASTA BIANCA

DOUBLE-FIRED WHITE BODY TILES

## SUPERFICI SURFACES

naturale - natural

## FORMATI SIZES



30x75  
12"x 30"



60x60  
24"x 24"



33,3x33,3  
13"x 13"

Pavimento coordinato in gres porcellanato  
Coordinating porcelain floor tiles (pag. 150)

▼  
9 mm  
▲



AGATA



STATUARIO



PULPIS GRIGIO



ALABASTRO

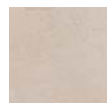

MARFIL

---

Classificazione secondo norme UNI EN 14411 (ISO 13006) Gruppo BIII GL  
Classification in accordance with UNI EN 14411 (ISO 13006) Group BIII GL



wall. Statuario. 30x75 - Theatre statuario 30x75 - Fascia micro argento 2x30 floor. Statuario lapp. extra rett. 60x60



# Grace

wall. Agata 30x75 - Agata Elegance - Dec. Elegance Agata floor. Agata 33,3x33,3





# Grace



30x75  5  
GRACE AGATA  
**GRN53150** F 48,90

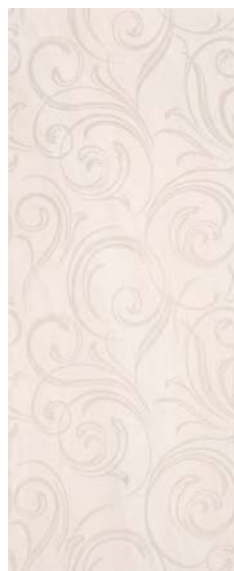

30x75  5  
GRACE ELEGANCE AGATA  
**GRN53151** F 53,90



30x75  2  
DEC. ELEGANCE AGATA  
**\*GRN53152** PZ 59,90



30x75  2  
DEC. HOME LINE AGATA  
**\*GRN53153** PZ 59,90



30x75  2  
DEC. HOME CROSSING  
**\*GRN53154** PZ 59,90



5x30  4  
LONDON AGATA  
**GRN53157** PZ 15,90  
Lato superiore smaltato  
Glazed upper side



2x30  4  
FASCIA MICRO ORO  
**\*SCT066** PZ 13,90



30x30  4  
MOS. CROSS AGATA  
**GRN53161** F 159,90



30x75  2  
DEC. ACANTUS AGATA  
**\*GRN53155** PZ 59,90



15x75  2  
LIST. ACANTUS AGATA  
**\*GRN53156** PZ 33,90

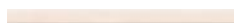

2x30  4  
MATITA AGATA  
**GRN53158** PZ 9,90

Pavimento coordinato  
in gres porcellanato  
Coordinating porcelain floor tiles



33,3x33,3  11  
GRACE AGATA  
**GRN27150** F 48,90



15x30  4  
BATTISCOPA AGATA  
**GRN53159** PZ 24,90

\* Articoli realizzati con metalli preziosi; si consiglia di pulire la superficie senza utilizzare prodotti contenenti sostanze abrasive.  
Items produced with precious metals; do not use products containing abrasive substances to clean the surface.

# Grace



30x75  5  
GRACE STATUARIO  
GRN53050 F 48,90



30x75  5  
THEATRE STATUARIO  
GRN53300 F 53,90



30x75  5  
GRACE ELEGANCE STAT.  
GRN53051 F 53,90



30x75  2  
DEC. ELEGANCE STAT.  
\*GRN53052 PZ 59,90



5x30  4  
LONDON STATUARIO  
GRN53057 PZ 15,90  
Lato superiore smaltato  
Glazed upper side



2x30  4  
FASCIA MICRO ARGENTO  
\*SCT067 PZ 13,90

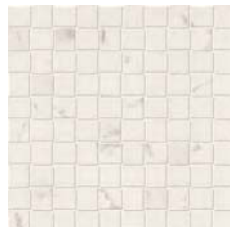

30x30  4  
MOS. CROSS STATUARIO  
GRN53061 F 159,90



2x30  4  
MATITTA STATUARIO  
GRN53058 PZ 9,90



6,5x30  4  
LISTELLO VENERE PLATINO  
\*GRN53060 PZ 19,90



15x30  4  
BATTISCOPA STATUARIO  
GRN53059 PZ 24,90

\* Articoli realizzati con metalli preziosi; si consiglia di pulire la superficie senza utilizzare prodotti contenenti sostanze abrasive.  
Items produced with precious metals; do not use products containing abrasive substances to clean the surface.



30x75  2  
DEC. HOME LINE STAT.  
\* **GRN53053** PZ 59,90



30x75  2  
DEC. HOME CROSSING STAT.  
\* **GRN53054** PZ 59,90



30x75  2  
DEC. ACANTUS STATUARIO  
\* **GRN53055** PZ 59,90



15x75  2  
LIST. ACANTUS STATUARIO  
\* **GRN53056** PZ 33,90

Pavimento coordinato  
in gres porcellanato  
Coordinating porcelain floor tiles

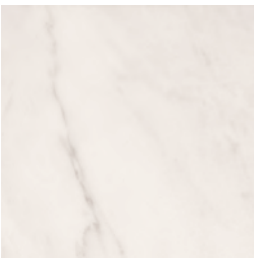

33,3x33,3  11  
GRACE STATUARIO  
\* **GRN27050** F 48,90



# Grace



30x75  5  
GRACE PULPIS GRIGIO  
GRN53200 F 48,90



30x75  5  
THEATRE PULPIS GRIGIO  
GRN53400 F 53,90



30x75  5  
GRACE ELEGANCE PULPIS GRIGIO  
GRN53201 F 53,90



30x75  2  
DEC. ELEGANCE PULPIS  
\*GRN53202 PZ 59,90



5x30  4  
LONDON PULPIS  
GRN53207 PZ 15,90  
Lato superiore smaltato  
Glazed upper side



2x30  4  
FASCIA MICRO ARGENTO  
\*SCT067 PZ 13,90



2x30  4  
MATITTA PULPIS  
GRN53208 PZ 9,90



6,5x30  4  
LISTELLO VENERE PLATINO  
\*GRN53060 PZ 19,90

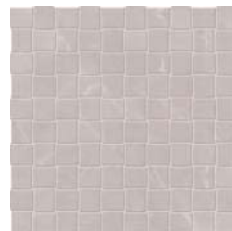

30x30  4  
MOS. CROSS PULPIS  
GRN53211 F 159,90



15x30  4  
BATTISCOPA PULPIS  
GRN53209 PZ 24,90

\* Articoli realizzati con metalli preziosi; si consiglia di pulire la superficie senza utilizzare prodotti contenenti sostanze abrasive.  
Items produced with precious metals; do not use products containing abrasive substances to clean the surface.



30x75  2  
DEC. HOME LINE PULPIS  
\* **GRN53203** PZ 59,90



30x75  2  
DEC. HOME CROSSING PULPIS  
\* **GRN53204** PZ 59,90



30x75  2  
DEC. ACANTUS PULPIS  
\* **GRN53205** PZ 59,90



15x75  2  
LIST. ACANTUS PULPIS  
\* **GRN53206** PZ 33,90

Pavimento coordinato  
in gres porcellanato  
Coordinating porcelain floor tiles

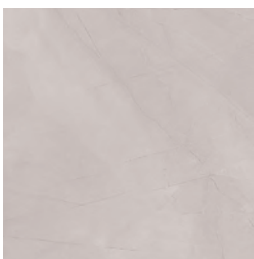

33,3x33,3  11  
GRACE PULPIS GRIGIO  
\* **GRN27200** F 48,90

# Grace



30x75  5  
GRACE ALABASTRO  
**GRN53100** F 48,90



30x75  5  
THEATRE ALABASTRO  
**GRN53350** F 53,90



30x75  5  
GRACE ELEGANCE ALABASTRO  
**GRN53101** F 53,90



30x75  2  
DEC. ELEGANCE ALABASTRO  
**\*GRN53102** PZ 59,90



5x30  4  
LONDON ALABASTRO  
**GRN53107** PZ 15,90  
Lato superiore smaltato  
Glazed upper side



2x30  4  
FASCIA MICRO ORO  
**\*SCT066** PZ 13,90



30x30  4  
MOS. CROSS ALABASTRO  
**GRN53111** F 159,90

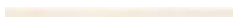

2x30  4  
MATITTA ALABASTRO  
**GRN53108** PZ 9,90



6,5x30  4  
LISTELLO VENERE ORO  
**\*GRN53110** PZ 19,90



15x30  4  
BATTISCOPA ALABASTRO  
**GRN53109** PZ 24,90

\* Articoli realizzati con metalli preziosi; si consiglia di pulire la superficie senza utilizzare prodotti contenenti sostanze abrasive.  
Items produced with precious metals; do not use products containing abrasive substances to clean the surface.





30x75  2  
DEC. HOME LINE ALABASTRO  
\* **GRN53103** PZ 59,90



30x75  2  
DEC. HOME CROSSING ALAB.  
\* **GRN53104** PZ 59,90



30x75  2  
DEC. ACANTUS ALABASTRO  
\* **GRN53105** PZ 59,90



15x75  2  
LIST. ACANTUS ALABASTRO  
\* **GRN53106** PZ 33,90

Pavimento coordinato  
in gres porcellanato  
Coordinating porcelain floor tiles



33,3x33,3  11  
GRACE ALABASTRO  
\* **GRN27100** F 48,90

# Grace



30x75  5  
GRACE MARFIL  
GRN53250 F 48,90



30x75  5  
THEATRE MARFIL  
GRN53450 F 53,90



30x75  5  
GRACE ELEGANCE MARFIL  
GRN53251 F 53,90



30x75  2  
DEC. ELEGANCE MARFIL  
\*GRN53252 PZ 59,90



5x30  4  
LONDON MARFIL  
GRN53257 PZ 15,90  
Lato superiore smaltato  
Glazed upper side



2x30  4  
FASCIA MICRO ORO  
\*SCT066 PZ 13,90



30x30  4  
MOS. CROSS MARFIL  
GRN53261 F 159,90



2x30  4  
MATITA MARFIL  
GRN53258 PZ 9,90



6,5x30  4  
LISTELLO VENERE ORO  
\*GRN53110 PZ 19,90



15x30  4  
BATTISCOPIA MARFIL  
GRN53259 PZ 24,90

\* Articoli realizzati con metalli preziosi; si consiglia di pulire la superficie senza utilizzare prodotti contenenti sostanze abrasive.  
Items produced with precious metals; do not use products containing abrasive substances to clean the surface.



30x75  2  
DEC. HOME LINE MARFIL  
\* **GRN53253** PZ 59,90



30x75  2  
DEC. HOME CROSSING MARFIL  
\* **GRN53254** PZ 59,90



30x75  2  
DEC. ACANTUS MARFIL  
\* **GRN53255** PZ 59,90



15x75  2  
LIST. ACANTUS MARFIL  
\* **GRN53256** PZ 33,90

Pavimento coordinato  
in gres porcellanato  
Coordinating porcelain floor tiles



33,3x33,3  11  
GRACE MARFIL  
\* **GRN27250** F 48,90

## IMBALLI/PACKAGING

F.to nominale Nominal size	F.to reale (mm) Real size (mm)	Spessore Thickness	Pz/Scatola Pcs/Box	Mq/Scatola Sqm/Box	Kg/Scatola Kg/Box	Scatole/Imballo Box/Packing	Mq totali Sqm total	Kg totali Kg total
30x75 / 12"x30"	-	9 mm	5	1,13	17,60	36	40,68	654
33,3x33,3 / 13"x13"	-	9 mm	11	1,22	24,00	44	53,68	1076

L'unità minima di vendita per tutti gli articoli (fondi, decori e pezzi speciali) è la scatola completa. / The minimum sales quantity for all items (plain tiles, decorations and special trims) is one full box.  
I dati relativi agli imballi sono aggiornati al momento della stampa del catalogo e pertanto possono subire variazioni nel corso del tempo. / Data referring to packaging have been update at time of printing; the actual data may be slightly different.  
Pezzi speciali e decori per effetto delle lavorazioni, possono presentare variazioni di tonalità. / Due to working process special trims and decors, may show variation in tonality.



# Tracks

---

## PASTA BIANCA DA RIVESTIMENTO

WHITE BODY WALL TILES

## SUPERFICI SURFACES

naturale - natural

## FORMATI SIZES



25x75  
10"x 30"

10,5 mm



WHITE

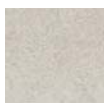

GREY



IVORY



SAND

---

Classificazione secondo norme UNI EN 14411 (ISO 13006) Gruppo BIII GL  
Classification in accordance with UNI EN 14411 (ISO 13006) Group BIII GL



wall. Grey 25x75 - Groove White 25x75 - Fascia Ardesia Grigio 4x30 floor. Soleras Grigio Rett. 20x120



# Tracks

wall. Sand 25x75 - Ivory 25x75 - Groove Ivory 25x75 - Fascia Essenze Mix 5x30 floor. Dolphin Oak Rett. 20x120





wall. Sand 25x75 - Groove Sand 25x75 - Mos. Rettangoli Ivory 25x25 - Fascia Vetro Bronzo 1,5x30 floor. Docks Warm Rett. 60x60



# Tracks



25x75  7  
TRACKS WHITE  
0000069 F 42,90

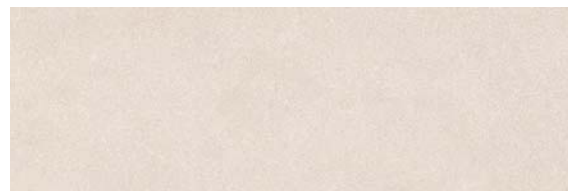

25x75  7  
TRACKS IVORY  
0000071 F 42,90



25x75  7  
TRACKS GROOVE WHITE  
0000073 F 46,90



25x75  7  
TRACKS GROOVE IVORY  
0000075 F 46,90

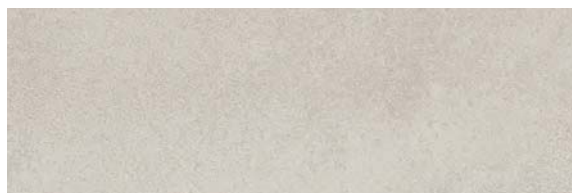

25x75  7  
TRACKS GREY  
0000070 F 42,90

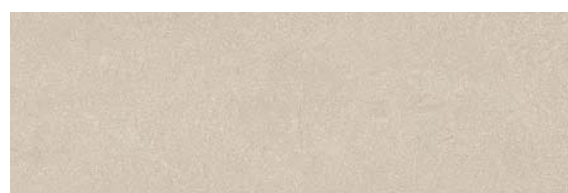

25x75  7  
TRACKS SAND  
0000072 F 42,90



25x75  7  
TRACKS GROOVE GREY  
0000074 F 46,90



25x75  7  
TRACKS GROOVE SAND  
0000076 F 46,90



25x25  4  
TRACKS MOSAICO  
RETTANGOLI WHITE  
0000096 PZ 12,90



25x25  4  
TRACKS MOSAICO  
RETTANGOLI GREY  
0000097 PZ 12,90



25x25  4  
TRACKS MOSAICO  
RETTANGOLI IVORY  
0000098 PZ 12,90

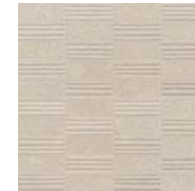

25x25  4  
TRACKS MOSAICO  
RETTANGOLI SAND  
0000099 PZ 12,90



5x30  4  
FASCIA ESSENZE MIX  
\***19R03053** PZ 21,90  
(Legno - Wood)



4x30  4  
FASCIA ARDESIA GRIGIO  
\***RER09204** rett. PZ 20,90  
(Pietra naturale - Natural stone)



4x30  4  
FASCIA ARDESIA BRONZO  
\***RER09054** rett. PZ 20,90  
(Pietra naturale - Natural stone)

\* Art. realizzati con materiali naturali:  
vedi indicazioni per posa e pulizia a pag. 393 dell' area tecnica.  
\* Items produced with natural materials:  
check the technical area at page 393.





1,5x30  4  
FASCIA VETRO ORO  
**R1R03106** PZ 22,90





1,5x30  4  
FASCIA VETRO BRONZO  
**R1R03157** PZ 22,90





1,5x30  4  
FASCIA VETRO PLATINO  
**R1R03207** PZ 22,90  
(Vetro e metalli preziosi - Glass and precious metals)





0,5x120  4  
MATITA ALLUMINIO  
**0000086** PZ 20,90





0,5x120  4  
MATITA ALLUMINIO WHITE  
**0000087** PZ 34,90



0,5x120  4  
MATITA ALLUMINIO BLACK  
**0000088** PZ 34,90



0,5x120  4  
MATITA ALLUMINIO RAME  
**0000556** PZ 34,90



0,5x120  4  
MATITA ALLUMINIO BRONZO  
**0000557** PZ 34,90  
(Alluminio - Aluminium)

## IMBALLI/PACKAGING

F.to nominale Nominal size	F.to reale (mm) Real size (mm)	Spessore Thickness	Pz/Scatola Pcs/Box	Mq/Scatola Sqm/Box	Kg/Scatola Kg/Box	Scatole/Imballo Box/Packing	Mq totali Sqm total	Kg totali Kg total
25x75 / 10"x30"	-	10,5 mm	7	1,31	24,70	42	55,02	1062

L'unità minima di vendita per tutti gli articoli (fondi, decori e pezzi speciali) è la scatola completa. / The minimum sales quantity for all items (plain tiles, decorations and special trims) is one full box.  
I dati relativi agli imballi sono aggiornati al momento della stampa del catalogo e pertanto possono subire variazioni nel corso del tempo. / Data referring to packaging have been update at time of printing; the actual data may be slightly different.  
Pezzi speciali e decori per effetto delle lavorazioni, possono presentare variazioni di tonalità. / Due to working process special trims and decors, may show variation in tonality.



# Aqua

---

## BICOTTURA IN PASTA BIANCA

DOUBLE-FIRED WHITE BODY TILES

## SUPERFICI SURFACES

naturale - natural

## FORMATI SIZES



20x60  
8"x 24"



33,3x33,3  
13"x 13"

Pavimento coordinato in gres porcellanato  
Coordinating porcelain floor tiles

▼  
9 mm  
▲



MAGNOLIA  
CHIARO



CIPRIA  
MEDIO



AMETISTA  
SCURO

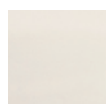

CENERE  
CHIARO

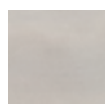

TORTORA  
MEDIO



OLTREMARE  
SCURO



AVORIO  
CHIARO



CANNELLA  
MEDIO

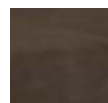

VISONE  
SCURO

---

Classificazione secondo norme UNI EN 14411 (ISO 13006) Gruppo BIII GL  
Classification in accordance with UNI EN 14411 (ISO 13006) Group BIII GL



wall. Magnolia Chiaro - Cipria Medio - Ametista scuro 20x60 - Dec. Poesia mix 2 magnolia - List. Poesia Cipria floor. Soleras bianco 20x120



**Aqua** wall. Avorio chiaro 20x60 - Dec. Mare Avorio floor. Soleras beige 20x120







20x60 13  
AQUA AVORIO CHIARO  
**AQ350** F 42,90



20x60 13  
AQUA CANNELLA MEDIO  
**AQ400** F 42,90



20x60 13  
AQUA VISCIONE SCURO  
**AQ450** F 42,90

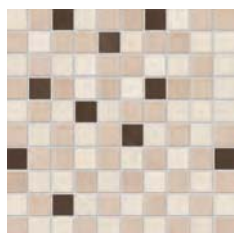

30x30 4  
MOS. MIX AVO/CANN/VISONE  
**\*\*AQ360** PZ 20,90



20x60 13  
DEC. MARE AVORIO  
**\*AQ351A** PZ 5,90



3,5x20 6  
LONDON CANNELLA MEDIO  
**\*\*AQ401** PZ 10,90



20x60 2  
DEC. PRIMAVERA MIX 2 AVORIO  
**\*AQ352** (cad.) PZ 49,90



3,5x3 2  
ANG. LONDON CANNELLA MEDIO  
**AQ402** PZ 10,90



2x60 4  
MATITA PRIMAVERA VISCIONE  
**AQ451** PZ 19,90

Pavimento coordinato in gres porcellanato / Coordinating porcelain floor tiles



33,3x33,3 11  
AQUA PAV. CANNELLA MEDIO  
**AQ4000** F 42,90

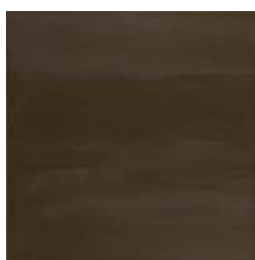

33,3x33,3 11  
AQUA PAV. VISCIONE SCURO  
**AQ4500** F 42,90

\* Articoli soggetti a stonalizzazione. / Colour - Shaded Tiles.

\*\* Mosaico senza rete. Le singole tessere sono tenute insieme da una pellicola trasparente adesiva applicata in superficie, che contribuisce a dare maggiore regolarità alle fughe durante le operazioni di posa su supporti ondulati. Si consiglia di rimuovere l'adesivo solo quando i collanti avranno fatto presa e di procedere con la normale stuccatura.

The mosaic are not mesh-mounted. The individual tiles are held together by a transparent adhesive film applied to the surface, which helps to give greater regularity to the joints in case of an undulated installation. We recommend to remove the adhesive film only when the grout is dry, and then to proceed with the joint filling.

\*\* Lato superiore smaltato. / Glazed upper side.

# Aqua



20x60  13  
AQUA MAGNOLIA CHIARO  
**AQ050** F 42,90



20x60  13  
AQUA CIPRIA MEDIO  
**AQ100** F 42,90



20x60  13  
AQUA AMETISTA SCURO  
**AQ150** F 42,90

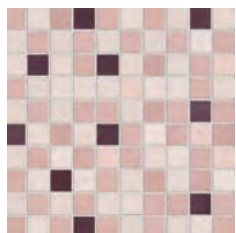

30x30  4  
MOS. MIX MAGN/CIPR/AMET.  
**\*\*AQ060** PZ 20,90



20x60  2  
DEC. POESIA MIX 2 MAGNOLIA  
**\*AQ053** (cad.) PZ 49,90



20x60  13  
DEC. PREZIOSO MAGNOLIA  
**\*AQ051A** PZ 5,90



3x60  4  
LIST. PERLE AMETISTA  
**AQ151** PZ 25,90



2x60  4  
LIST. POESIA CIPRIA  
**AQ101** PZ 19,90

Pavimento coordinato in gres porcellanato / Coordinating porcelain floor tiles



33,3x33,3  11  
AQUA PAV. CIPRIA MEDIO  
**AQ1000** F 42,90

\*Articoli soggetti a stonizzazione. / Colour - Shaded Tiles.

\*\*Mosaico senza rete. Le singole tessere sono tenute insieme da una pellicola trasparente adesiva applicata in superficie, che contribuisce a dare maggiore regolarità alle fughe durante le operazioni di posa su supporti ondulati. Si consiglia di rimuovere l'adesivo solo quando i collanti avranno fatto presa e di procedere con la normale stuccatura.

**358** The mosaic are not mesh-mounted. The individual tiles are held together by a transparent adhesive film applied to the surface, which helps to give greater regularity to the joints in case of an undulated installation. We recommend to remove the adhesive film only when the grout is dry, and then to proceed with the joint filling.

\*\* Lato superiore smaltato. / Glazed upper side.



20x60  13  
AQUA CENERE CHIARO  
**AQ200** F 42,90



20x60  13  
AQUA TORTORA MEDIO  
**AQ250** F 42,90



20x60  13  
AQUA OLTREMARE SCURO  
**AQ300** F 42,90



30x30  4  
MOS. MIX CEN/TORT/OLTREM.  
**\*\*AQ210** PZ 20,90



20x60  2  
DEC. FANTASIA MIX 2 CENERE  
**\*AQ203** (cad.) PZ 49,90



3x60  4  
LIST. ONDE OLTREMARE  
**AQ302** PZ 25,90



1x60  4  
MATITA OLTREMARE  
**AQ301** PZ 19,90  
(Alluminio - Aluminium)

Pavimento coordinato in gres porcellanato / Coordinating porcelain floor tiles



33,3x33,3  11  
AQUA PAV. TORTORA MEDIO  
**AQ2500** F 42,90



33,3x33,3  11  
AQUA PAV. OLTREMARE SCURO  
**AQ3000** F 42,90

#### IMBALLI/PACKAGING

F.to nominale Nominal size	F.to reale (mm) Real size (mm)	Spessore Thickness	Pz/Scatola Pcs/Box	Mq/Scatola Sqm/Box	Kg/Scatola Kg/Box	Scatole/Imballo Box/Packing	Mq totali Sqm total	Kg totali Kg total
20x60 / 8"x24"	-	9 mm	13	1,56	26,56	44	68,64	1189
33,3x33,3 / 13"x13"	-	9 mm	11	1,22	24,00	44	53,68	1076

L'unità minima di vendita per tutti gli articoli (fondi, decori e pezzi speciali) è la scatola completa. / The minimum sales quantity for all items (plain tiles, decorations and special trims) is one full box.  
I dati relativi agli imballi sono aggiornati al momento della stampa del catalogo e pertanto possono subire variazioni nel corso del tempo. / Data referring to packaging have been update at time of printing; the actual data may be slightly different.  
Pezzi speciali e decori per effetto delle lavorazioni, possono presentare variazioni di tonalità. / Due to working process special trims and decors, may show variation in tonality.



# Vision

---

## BICOTTURA IN PASTA BIANCA

DOUBLE-FIRED WHITE BODY TILES

## SUPERFICI SURFACES

naturale - natural

## FORMATI SIZES



20x60  
8"x24"



WHITE SAT.

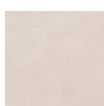

SAND SAT.



LADY SAT.



SMOKE SAT.

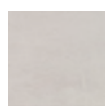

SILVER SAT.



WHITE LUX

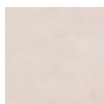

SAND LUX



SMOKE LUX

---

Classificazione secondo norme UNI EN 14411 (ISO 13006) Gruppo BIII GL  
Classification in accordance with UNI EN 14411 (ISO 13006) Group BIII GL



wall. White sat. 20x60 - Sand sat. 20x60 - Lady 20x60 - dec. Love 20x60 floor. Soleras beige 20x80



# Vision



20x60  13  
VISION WHITE SAT.  
**VIN20050** F 42,90



20x60  13  
VISION SAND SAT.  
**VIN20200** F 42,90



20x60  13  
VISION MOS. RETTANGOLI SAND SAT.  
**VIN20201** F 46,90



20x60  13  
VISION STYLE SAND SAT.  
**VIN20203** F 46,90



20x60  13  
VISION LADY SAT.  
**VIN20250** F 42,90



2x60  4  
LIST. RETTANGOLI SAND SAT.  
**VIN20202** PZ 12,90



3x60  4  
LISTELLO STYLE SAND  
**VIN20204** PZ 13,90



20x60  13  
VISION SILVER SAT.  
**VIN20100** F 42,90



20x60  13  
VISION MOS. RETTANGOLI SILVER SAT.  
**VIN20101** F 46,90



20x60  13  
VISION STYLE SILVER SAT.  
**VIN20103** F 46,90



20x60  13  
VISION SMOKE SAT.  
**VIN20150** F 42,90



2x60  4  
LIST. RETTANGOLI SILVER SAT.  
**VIN20102** PZ 12,90



3x60  4  
LISTELLO STYLE SILVER  
**VIN20104** PZ 13,90







20x60  2  
DEC. SWEDEN SAT. MIX 2  
VIN20051 PZ 29,90

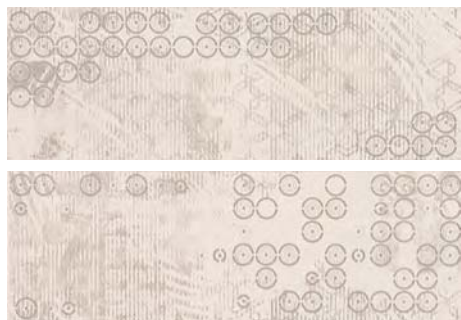

20x60  2  
DEC. LOVE SAT. MIX 2  
VIN20052 PZ 29,90



20x60  2  
DEC. POP SAT. MIX 2  
VIN20053 PZ 29,90



White / Silver sat. 20x60 - Mos. Rettangoli Silver

# Vision

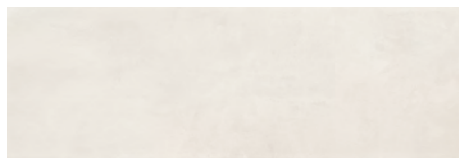

20x60  13  
VISION WHITE LUX  
VIN20500 F 42,90

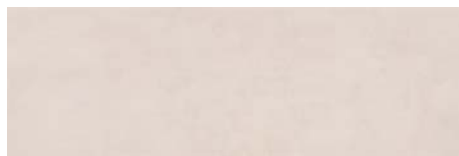

20x60  13  
VISION SAND LUX  
VIN20600 F 42,90



20x60  13  
VISION SMOKE LUX  
VIN20550 F 42,90



20x60  13  
VISION MOS. RETTANGOLI SAND LUX  
VIN20601 F 46,90



2x60  4  
LIST. RETTANGOLI SAND LUX  
VIN20602 PZ 12,90



2x60  4  
LISTELLO GRAPH SAND LUX  
VIN20502 PZ 12,90



20x60  2  
DEC. DESIRE LUX MIX 2  
\* VIN20503 PZ 29,90



20x60  2  
DECORO OWL MIX 2  
\* VIN20606 PZ 59,90

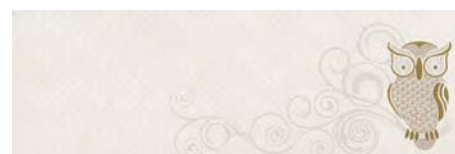

2,5x60  4  
\* LISTELLO OWL  
VIN20607 PZ 19,90

\* Articoli realizzati con metalli preziosi; si consiglia di pulire la superficie senza utilizzare prodotti contenenti sostanze abrasive.  
Items produced with precious metals; do not use products containing abrasive substances to clean the surface.

## IMBALLI/PACKAGING

F.to nominale Nominal size	F.to reale (mm) Real size (mm)	Spessore Thickness	Pz/Scatola Pcs/Box	Mq/Scatola Sqm/Box	Kg/Scatola Kg/Box	Scatole/Imballo Box/Packing	Mq totali Sqm total	Kg totali Kg total
20x60 / 8"x24"	-	9 mm	13	1,56	26,56	44	68,64	1189

L'unità minima di vendita per tutti gli articoli (fondi, decori e pezzi speciali) è la scatola completa. / The minimum sales quantity for all items (plain tiles, decorations and special trims) is one full box.  
I dati relativi agli imballi sono aggiornati al momento della stampa del catalogo e pertanto possono subire variazioni nel corso del tempo. / Data referring to packaging have been update at time of printing; the actual data may be slightly different.  
Pezzi speciali e decori per effetto delle lavorazioni, possono presentare variazioni di tonalità. / Due to working process special trims and decors, may show variation in tonality.



White / smoke Lux 20x60 - Dec. Owl White - List. Owl



# Zanzibar

---

## BICOTTURA IN PASTA BIANCA

DOUBLE-FIRED WHITE BODY TILES

## SUPERFICI SURFACES

naturale - natural

## FORMATI SIZES



20x50  
8"x 20"



50x50  
20"x 20"



33,3x33,3  
13"x 13"

Pavimento coordinato in gres porcellanato  
Coordinating porcelain floor tiles (pag. 282)

▼  
9 mm  
▲

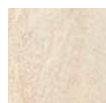

SABBIA CHIARO



SABBIA SCURO

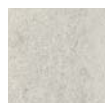

GRIGIO CHIARO



GRIGIO SCURO

---

Classificazione secondo norme UNI EN 14411 (ISO 13006) Gruppo BIII GL  
Classification in accordance with UNI EN 14411 (ISO 13006) Group BIII GL



**wall.** Sabbia chiaro / Sabbia scuro 20x50 - Dec. Odalisca Sabbia/Ocra - List. Odalisca Sabbia/Ocra **floor.** Sabbia chiaro 33,3x33,3



# Zanzibar



20x50  15  
ZANZIBAR SABBIA CHIARO  
**ZA100** F 36,90



20x50  15  
ZANZIBAR SABBIA SCURO  
**ZA150** F 36,90



20x50  6  
FASCIA ODALISCA SABBIA/OCRA  
\* **ZA115** PZ 41,90



2,5x25  12  
LISTELLO REEF SABBIA/GRIGIO  
**ZA101** PZ 14,90



3x50  12  
LISTELLO ODALISCA SABBIA/OCRA  
\* **ZA116** PZ 14,90

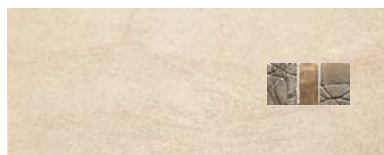

20x50  12  
FORO ZANZIBAR SABBIA  
**ZA120** PZ 8,90



5x20  12  
LIST. ZANZIBAR SABBIA (vetro - glass)  
**ZA122** PZ 25,90

5x10  12  
TOZZ. ZANZIBAR SABBIA (vetro - glass)  
**ZA121** PZ 18,90

Pavimento coordinato in gres porcellanato a pagina 282  
Coordinating porcelain floor tiles page 282



33,3x33,3  11  
ZANZIBAR SABBIA CHIARO  
**ZA6000C** F 31,90



33,3x33,3  11  
ZANZIBAR SABBIA SCURO  
**ZA6500C** F 31,90

\*Si consiglia di pulire la superficie senza utilizzare prodotti contenenti sostanze abrasive per non alterare la brillantezza del metallo prezioso.  
Do not use products containing abrasive substances to clean the decorative element so as not to affect the shine of the precious metal.





20x50 15  
ZANZIBAR GRIGIO CHIARO  
**ZA200** F 36,90



20x50 15  
ZANZIBAR GRIGIO SCURO  
**ZA250** F 36,90



20x50 6  
FASCIA ODALISCA GRIGIO  
\* **ZA215** PZ 41,90



2,5x25 12  
LISTELLO REEF SABBIA/GRIGIO  
**ZA101** PZ 14,90



3x50 12  
LISTELLO ODALISCA GRIGIO  
\* **ZA216** PZ 14,90

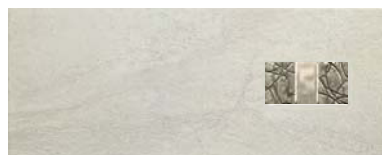

20x50 12  
FORO ZANZIBAR GRIGIO  
**ZA220** PZ 8,90



5x20 12  
LIST. ZANZIBAR GRIGIO (vetro - glass)  
**ZA222** PZ 25,90



5x50 12  
LISTELLO ATOLLI GRIGIO  
\* **ZA205** PZ 41,90



2,5x50 12  
CORDONE ATOLLI GRIGIO  
\* **ZA206** PZ 28,90

5x10 12  
TOZZ. ZANZIBAR GRIGIO (vetro - glass)  
**ZA221** PZ 18,90

Pavimento coordinato in gres porcellanato a pagina 282  
Coordinating porcelain floor tiles page 282

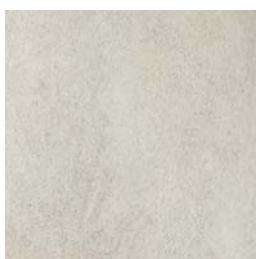

33,3x33,3 11  
ZANZIBAR GRIGIO CHIARO  
**ZA6050C** F 31,90



33,3x33,3 11  
ZANZIBAR GRIGIO SCURO  
**ZA6550C** F 31,90



10x50 18  
BULLNOSE PZ 12,90

**ZA401** SABBIA CHIARO  
**ZA451** SABBIA SCURO  
**ZA501** GRIGIO CHIARO  
**ZA551** GRIGIO SCURO

## IMBALLI/PACKAGING

F.to nominale Nominal size	F.to reale (mm) Real size (mm)	Spessore Thickness	Pz/Scatola Pcs/Box	Mq/Scatola Sqm/Box	Kg/Scatola Kg/Box	Scatole/Imballo Box/Packing	Mq totali Sqm total	Kg totali Kg total
20x50 / 8"x20"	-	9 mm	15	1,50	24,00	44	66,00	1076
33,3x33,3 / 13"x13"	-	9 mm	11	1,22	24,00	44	53,68	1076

L'unità minima di vendita per tutti gli articoli (fondi, decori e pezzi speciali) è la scatola completa. / The minimum sales quantity for all items (plain tiles, decorations and special trims) is one full box.  
I dati relativi agli imballi sono aggiornati al momento della stampa del catalogo e pertanto possono subire variazioni nel corso del tempo. / Data referring to packaging have been update at time of printing; the actual data may be slightly different.  
Pezzi speciali e decori per effetto delle lavorazioni, possono presentare variazioni di tonalità. / Due to working process special trims and decors, may show variation in tonality.

hardkoll

**COLLANTI E SIGILLANTI**

**PER EDILIZIA**

hardkoll

**BUILDING ADHESIVES**

**AND SEALANTS**

Entrata a far parte del Gruppo ABK nel 2015, Hardkoll è un'industria chimica specializzata nello sviluppo e nella produzione di soluzioni per l'edilizia che vuole porsi sul mercato come un partner attento in grado di fornire soluzioni complete per il mondo edile.

Ordinare Hardkoll oggi significa:

- avere a disposizione una gamma di prodotti sviluppati appositamente per le collezioni ABK che ne garantiscono il miglior risultato tecnico ed estetico
- includere i prodotti Hardkoll insieme ai materiali ABK in un unico ordine e un'unica fatturazione
- convenienza nei costi di trasporto: i prodotti Hardkoll potranno essere caricati unitamente ai prodotti ABK presso lo stesso magazzino logistico
- assistenza tecnica specializzata
- prodotti certificati che coprono tutte le casistiche di posa

## COLLANTI PER EDILIZIA

Gli adesivi edilizi sono un insieme di sostanze naturali o sintetiche, che, opportunamente applicate, sono capaci di far aderire fra loro superfici di materiali uguali o diversi. L'azione degli adesivi deriva da fattori interni (composizione, proprietà chimiche delle sostanze utilizzate) ed esterni (condizioni atmosferiche – ambiente umido/asciutto – materiali da incollare – ceramica/pietra naturale/ricomposti – supporto sul quale incollare – massetto/ moquette/laminato – destinazione finale – pavimento/rivestimento/interni/esterni); tali fattori ne determinano la composizione chimica e dunque le differenti tipologie. In generale possiamo affermare che ciascuno di essi viene identificato con una lettera ed un numero in progressione, che ne determina l'upgrade di prestazione: sono tutti universalmente validi.

C1: collante a base cementizia, basico (per materiale ceramico poroso/assorbente o bicottura).

C2: collante a base cementizia migliorato (per materiali ceramici non assorbenti).

F: collante a presa rapida (fast). E' utilizzato per esempio in condizioni di cantiere particolari e in tutte quelle situazioni che richiedono rapidità di intervento.

T: il collante ha un comportamento tixotropico (ovvero antiscivolo: dunque particolarmente apprezzato per la posa su parete di materiali di grandi formati e/o spessori maggiorati).

E: tempo aperto allungato (extended) ovvero il tempo massimo entro il quale il materiale può essere posato dopo l'applicazione dell'adesivo.

S1: il collante è deformabile (stretchy) ovvero ammortizza le tensioni termiche delle piastrelle e della superficie di posa senza danneggiare la superficie installata.

S2: variante migliorata della precedente.

Tutte queste caratteristiche possono coesistere e combinarsi fra loro, dando vita a variegate tipologie.

Il collante è l'ultimo strato prima del materiale scelto per la pavimentazione (legno, materiale ceramico, pietra naturale, etc) e contribuisce alla solidità del pavimento stesso: bisogna dunque non solo applicarlo con cura ma anche e soprattutto scegliere la tipologia idonea al materiale e al cantiere.

As part of the ABK Group since 2015, Hardkoll is a chemical manufacturer qualified in the development and production of building solutions.

Hardkoll aims to be a reliable partner able to supply complete systems for buildings.

Today, placing an order of Hardkoll products means:

- A wide range of products specifically developed on ABK collections, guaranteeing the best technical and aesthetic result
- One loading and one invoice together with ABK materials
- Transport costs convenience: Hardkoll products can be loaded together with ABK products at the same logistic warehouse
- Technical support
- Certified products for all laying solutions

## BUILDING ADHESIVES

Building adhesives are a mix of chemicals or natural substances providing or promoting adhesion.

Adhesives strength is depending on 2 different features: internal (chemical composition and chemical properties of the substances) and external (weather conditions - damp/dry room – materials to glue – ceramics/quarry stones/wood-rest where materials have to be glued - screed/ carpet/ laminate – end use – floor/wall, interiors/exterior). All these set out the chemical composition and the varieties. The different kind of binding materials are identified by an alphabetical letter and a progressive number, specifying the upgrading performance.

C1: cement glue (for absorbing ceramic materials).

C2: improved cement glue (for not absorbing ceramic materials).

F: fast glue (usually less than 30 minutes); used whenever and wherever fast action is required, even during winter in order to prevent the freezing of the water.

T: tixotropic glue, i.e. antigrip (used for big sizes or extra thick wallcoverings).

E: open extended time (maximum time limit to fix down the material after the adhesive film application).

S1: stretchy glue i.e. thermal and shock absorber .

S2: highly stretchy glue (improved S1 glue).

All these, can be mixed together, giving out several types in return.

Binding materials are the last layer before tiles and support the firmness of the floor itself: it is crucial to select the proper one and to apply them properly.



## COLLANTI PER EDILIZIA / BUILDING ADHESIVES

Hardkoll consiglia: / Hardkoll suggests:



**BAUEXTRA:** classificazione C1TE ideale per la mono e bicottura fino a ca. 40x40 cm anche in parete.

**BAUEXTRA:** C1TE special for single and double-fired and wall tiles till up 40x40 cm.

### BAUEXTRA

BIANCO/WHITE	<b>AD110M</b>	€ 0,59/kg
GRIGIO/GREY	<b>AD100M</b>	€ 0,56/kg



**BAUFLEX MAXI S1:** classificazione C2TES1, grazie alla dimensione maggiorata del granello, è ideale per i materiali di spessore maggiorato da esterno (20 mm)

**BAUFLEX MAXI S1:** C2TES1 suggested for special thick materials for outdoors (20 mm)

### BAUFLEX MAXI S1

BIANCO/WHITE	<b>AD260M</b>	€ 1,24/kg
GRIGIO/GREY	<b>AD280M</b>	€ 1,17/kg



**BAULITE S2:** classificazione C2TES2, grazie alla nanotecnologia utilizzata, con un sacco di 15 kg si riesce a posare lo stesso quantitativo di materiale rispetto ad un sacco tradizionale (25 kg).

**BAULITE S2:** C2TES2 thanks to the nanotechnology, a 15 kg bag ensures the same performance of a 25 kg bag.

### BAULITE S2

BIANCO/WHITE	<b>AD340M</b>	€ 2,64/kg
GRIGIO/GREY	<b>AD341M</b>	€ 2,46/kg



**BAUPRIMERGRIP:** primer che migliora l'adesione di adesivi, rasanti e autolivellanti cementizi su supporti difficili e poco assorbenti.

**BAUPRIMERGRIP:** primer improving the adhesion of adhesives, plasters and self-leveling on not absorbing supports.

### BAUPRIMERGRIP

<b>AT1212</b>	€ 10,56/kg
---------------	------------

# HARDKOLL

LAYING INNOVATIONS



**BAUFLEX:** classificazione C2TE idoneo per la posa di qualsiasi formato di gres, anche in sovrapposizione di piastrelle preesistenti.

**BAUFLEX:** C2TE suggested for fine stone porcelainware, even for overlapping in case of existing floor.

### BAUFLEX

BIANCO/WHITE	<b>AD200M</b>	€ 1,03/kg
GRIGIO/GREY	<b>AD210M</b>	€ 1,01/kg



**+30:** classificazione C2TES1, ideale per la posa di piastrelle ceramiche di grande formato e/o basso spessore: la sua formula permette una resa del 30% maggiore rispetto agli altri adesivi equivalenti.

**+30:** C2TES1: suggested for laying extra thin big ceramic slabs; the enriched formula allows a 30% better performance compared to other equivalent adhesives.

### +30

BIANCO/WHITE	<b>AD330M</b>	€ 1,29/kg
GRIGIO/GREY	<b>AD331M</b>	€ 1,17/kg



**BAURAPID:** classificazione C2FTS1, si tratta di un collante a presa rapida già calpestabile dopo 5 ore.

**BAURAPID:** C2FTS1 a fast adhesive ready already 5 hours after the first application.

### BAURAPID

GRIGIO/GREY	<b>AD240M</b>	€ 1,27/kg
-------------	---------------	-----------

## STUCCO PER FUGHE

Lo stucco é un sigillante riempitivo per fughe e può essere più o meno idrorepellente e a base o cementizia o epossidica  
CG2: a base cementizia migliorata, ad elevata resistenza all'abrasione e basso assorbimento di acqua

RG: a base epossidica, ad elevata resistenza all'abrasione

## GROUT SEALANT

Grout is a joint filling seal and can be waterproof and cement or epoxy based

CG2: improved cement based grout, abrasion resistant and water low absorption

RG: high abrasion resistance and epoxy based



**KROMOS 08:** ideale per fughe sottili, materiali rettificati; presenta una finitura particolarmente liscia.

**KROMOS 08:** smooth thin grout for rectified tiles.



**BAUPOXI HD10:** stucco a base epossidica, totalmente non assorbente, evita la formazione di muffe e batteri, ideale per ambienti molto umidi (bagni, cucine, piscine, etc).

**BAUPOXI HD10:** epoxy waterproof grout, not absorbing, avoiding mould and bacterium, special suggested for very wet areas (pools, bathrooms, kitchens, ect).

### KROMOS 08

\* = 2,23 €/kg

\*\* = 2,50 €/kg

\*\*\* = 2,72 €/kg

### BAUPOXI HD10

BIANCO/WHITE € 15,83/kg

COLORATO/COLORED € 14,66/kg

Kromos 08 e BauPoxy HD10 presentano oggi una nuova gamma di cromie sviluppate appositamente per i materiali ABK, assicurando così un'eccellente resa estetica.

Kromos 08 and BauPoxy HD10 introduce a new colour range specifically developed for ABK products, ensuring an excellent final look

	BIANCO	KROMOS SI124B **		ARDESIA	KROMOS SI152B ***		TORTORA	KROMOS SI153B ***
		BAUPOXI PP124P			BAUPOXI PP152P			BAUPOXI PP153P
	GRIGIO LUCE	KROMOS SI120B *		ANTRACITE	KROMOS SI122B *		NOCCIOLA	KROMOS SI143B ***
		BAUPOXI PP120P			BAUPOXI PP122P			BAUPOXI PP143P
	PERLA	KROMOS SI150B ***		NERO	KROMOS SI140B **		AVANA	KROMOS SI154B ***
		BAUPOXI PP150P			BAUPOXI PP140P			BAUPOXI PP154P
	MANHATTAN	KROMOS SI123B *		AVORIO	KROMOS SI126B **		TABACCO	KROMOS SI133B ***
		BAUPOXI PP123P			BAUPOXI PP126P			BAUPOXI PP133P
	BETULLA	KROMOS SI151B ***		JASMIN	KROMOS SI125B **		MARRONE	KROMOS SI134B ***
		BAUPOXI PP151P			BAUPOXI PP125P			BAUPOXI PP134P
	CEMENTO	KROMOS SI121B *		BAHAMA BEIGE	KROMOS SI129B **		NOCE	KROMOS SI155B ***
		BAUPOXI PP121P			BAUPOXI PP129P			BAUPOXI PP155P

## IMPERMEABILIZZANTE

L'impermeabilizzante è una guaina che si posa sopra il massetto allo scopo di proteggerlo dall'acqua: per la sua stesura è necessario che il sottofondo sia perfettamente asciutto.

## SEALING

Sealing is a film that has to be fixed on the concrete to protect it from water; it has to be used on backgrounds perfectly dried.



**BAU820 (A+B):** utilizzabile quando il massetto, stagionato, presenta condizioni di umidità superficiale, e in presenza di temperature rigide.

**BAU820 (A+B):** It can be used when the concrete is not completely dried and/or in case of cold temperature.



**BAUNET:** soluzione per la pulizia di piastrelle e giunti cementizi

**BAUNET:** cleaning solution for tiles and groutings

### BAUNET

5L AT1302 € 3,05/kg

1L x 12 AT1301 € 4,10

1KG x 12 AP1301 € 11,14

### BAU820 (A+B)

BIANCO 18 KG PP150N € 5,28/kg

# informazioni tecniche

**TECHNICAL INFORMATION**



WIDE	376
AUTOLEVELING e INSTA-TILE	383
W&P	386
OUT.20 20 MM (POSA / LAYING SYSTEM)	388
FACCIAE VENTILATE / VENTILATED FACADES	390
CONSIGLI DI POSA E PULIZIA / INSTALLATION AND CLEANING ADVICE	392
CARATTERISTICHE TECNICHE / TECHNICAL CHARACTERISTICS	396
ECOSOSTENIBILITA' / ECO-SUSTAINABILITY	400
GUIDA ALLA CONSULTAZIONE / CONSULTATION GUIDE	401
CONDIZIONI GENERALI DI VENDITA / GENERAL SALES TERMS AND CONDITIONS	402

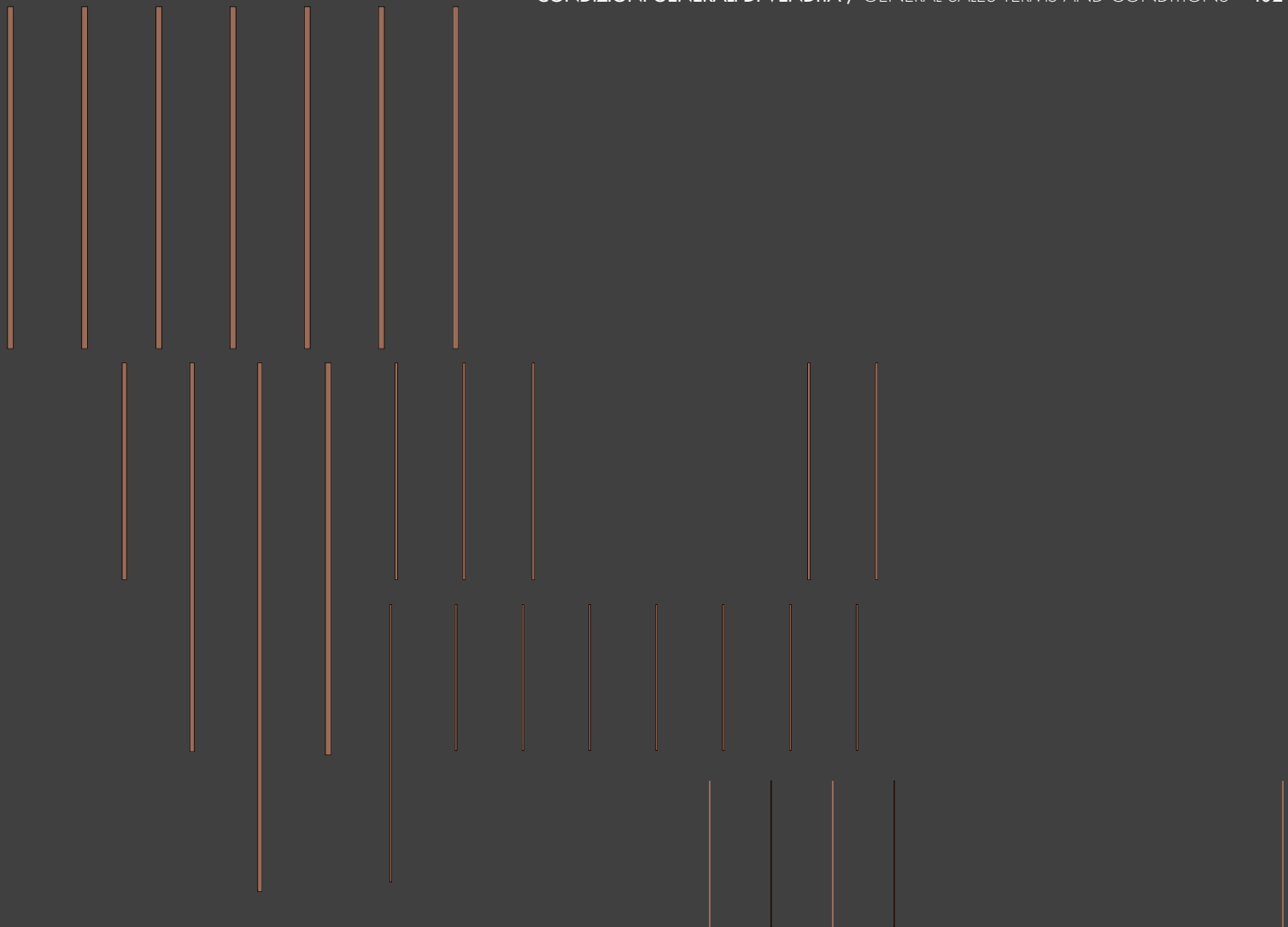

# WIDE

## SUPERSIZE SLABS

### CERAMIC R-EVOLUTION

Il progetto WIDE ABK parte dalla rivoluzionaria tecnologia produttiva CONTINUA+, che permette di produrre lastre in gres porcellanato robuste e leggere allo stesso tempo, grazie allo spessore ridotto di 7mm, fino alla dimensione record di 160x320 cm.

Il nuovo sistema di pressatura prevede la compattazione a secco delle materie prime e consente di ottenere superfici particolarmente apprezzabili sia per la qualità estetica che per le performance tecniche.

ABK's WIDE collection consists of tough yet lightweight porcelain slabs with a thickness of just 7 mm and a record size of 160x320 cm produced using the revolutionary CONTINUA+ technology. The new pressing system involves dry compaction of raw materials and is able to produce surfaces that combine excellent aesthetic quality with outstanding technical performance.



#### WIDE & STRONG

WIDE è perfettamente idoneo sia per il rivestimento che per la pavimentazione, in ambito residenziale e commerciale. Lo spessore 7 mm consente di mantenere un'ottima resistenza al carico di rottura reale.

WIDE is ideal as both a floor and wall covering in residential and commercial projects. The 7 mm thickness enables it to maintain excellent breaking strength in real situations.



#### LITE GOES WIDE

Lo spessore di 7 mm consente di ridurre il peso per mq con interessanti vantaggi in termini di maneggevolezza e movimentazione.

The 7 mm thickness results in a reduced weight per square metre, bringing significant advantages in terms of ease of working and handling.



#### WIDE IS LEVELING

La combinazione fra impasto ad elevata plasticità, spessore e grande dimensione, dona particolare elasticità al prodotto, per ottenere risultati di posa sempre impeccabili.

The combination of a body with high plasticity, thickness and dimensions makes for a highly elastic product that delivers consistently flawless results.



#### EASY AS WIDE

La formulazione dell'impasto, unita alla compattazione a secco e alla cottura in forni di nuova concezione, genera un gres particolarmente facile da tagliare e lavorare.

The chemical formulation of the body combined with the raw material dry compaction process produces a porcelain slab that is easy to cut and work with.



#### WIDE MEANS GREEN

L'impasto contiene il 40% minimo di materie prime di qualità recuperate da altri processi produttivi, per questo i prodotti WIDE possono essere accreditati all'interno del sistema internazionale LEED.

As the body contains a minimum of 40% high-quality raw materials recycled from other production processes, WIDE collection products qualify for LEED international certification.

#### CARICO DI ROTTURA BREAKING STRENGTH

ABK 9 mm = 1.662 newton  
ABK 7mm = 1.587 newton  
Altri 6 mm = 1.166 newton

#### PESO WEIGHT

ABK 9 mm = 19,5 Kg x mq  
ABK 7 mm = 17,5 Kg x mq

indicatore di flessibilità flexibility index	deflessione massima sotto carico di 350 N maximum deflection under load of 350 N	lato/length 2400 mm	> 50 mm
		lato/length 3200 mm	> 100 mm

### NEW DIMENSIONS

Uno degli obiettivi del progetto WIDE è quello di fornire un materiale ceramico tecnologicamente avanzato facilmente utilizzabile in contesti anche molto diversi, per dimensione e per destinazione d'uso. WIDE è un vero e proprio programma di formati, tutti rettificati, pensati per coprire a 360° le esigenze legate alla progettazione, a partire dagli spazi residenziali, fino alle grandi opere in ambito pubblico e commerciale.

One of the aims of the WIDE project is to supply a hi-tech ceramic material that is easy to use in very different sizes and applications. WIDE comes in a large selection of sizes, all rectified, ideal for uses ranging from residential through to large-scale works in public and commercial spaces.

7 mm



160x320 / 64"x128"

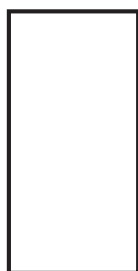

120x240 / 48"x96"



160x160 / 64"x 64"



80x160 / 32"x 64"



120x120 / 48"x 48"



80x80 / 32"x 32"



## EVERYWHERE YOU LIKE

Tenendo conto delle principali qualità del materiale, tra cui la robustezza, la resistenza agli sbalzi termici, oltre allo spessore contenuto e alla facilità di lavorazione, le grandi lastre WIDE ampliano la destinazione d'uso del gres porcellanato. Sempre meno fughe e sempre più spazio alla creatività di progettisti e interior designers, che grazie ai prodotti WIDE possono apprezzare la versatilità di una ceramica senza più confini.

Taking account of the material's key qualities, including strength, thermal shock resistance, low thickness and ease of working, the WIDE large-format slabs extend the fields of use of porcelain. The WIDE collection has fewer joints while giving enormous creative freedom to architects and interior designers, who appreciate the versatility of this ceramic surface without limits.



PAVIMENTI INTERNI  
INDOOR FLOORS



RIVESTIMENTI INTERNI  
INDOOR WALLS



+

FACCIAE ESTERNE  
INCOLLATE E VENTILATE  
GLUED AND VENTILATED  
EXTERIOR FAÇADES

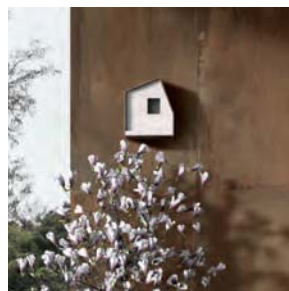

PAVIMENTI AREE ESTERNE  
OUTDOOR FLOORS



PIANI LAVORO CUCINE  
KITCHEN COUNTERTOPS



TOP E FINITURE PER  
AMBIENTI BAGNO  
BATHROOM VANITY TOPS  
AND SHELVES



ELEMENTI DI ARREDO E  
DESIGN PER INTERNI  
INTERIOR FURNISHING  
AND DESIGN ELEMENTS

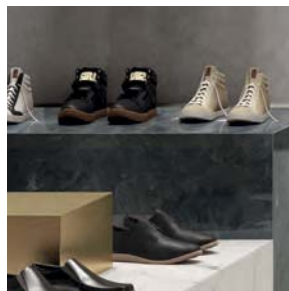



# WIDE

## SUPERSIZE SLABS

### LOGISTICA NUOVI SISTEMI DI IMBALLO

L'innovazione della gamma WIDE si esprime anche attraverso la parte logistica del progetto. ABK Group rivoluziona il sistema di imballaggio delle lastre ed è a oggi l'unica azienda che ha portato il sistema a cavalletto impilabile alla dimensione di cm 75x246x149.

Questi i principali vantaggi offerti:

- essendo impilabile permette di ottimizzare gli spazi all'interno dei magazzini.\*
- la profondità di 75 cm consente di sfruttare a pieno il volume di carico dei container (3 pallets ne occupano perfettamente la larghezza).
- Il posizionamento verticale del prodotto garantisce una maggiore protezione delle lastre durante le fasi di trasporto.
- facilita le operazioni sul cantiere in quanto le lastre si trovano già posizionate in verticale, il materiale è facilmente ispezionabile e removibile per l'installazione.
- le dimensioni complessive del cavalletto consentono maggiori spazi di manovra all'interno dei locali di posa rispetto alle casse tradizionali e agevolano il sollevamento del materiale mediante mezzi meccanici (gru-montacarichi).
- è caratterizzato da un sistema di regettatura che consente di liberare anche 1 solo collo alla volta, senza compromettere la stabilità del materiale che rimane sul pallet, evitando così il rischio di rotture. Le lastre dovranno essere liberate rispettando la sequenza opposta rispetto a quella con cui sono state confezionate, quindi iniziando dall'ultimo collo regettato.

### LOGISTICS NEW PACKAGING SYSTEMS

Innovation in the WIDE range is also reflected in the project's logistics. ABK Group has revolutionised the packaging of ceramic slabs and is the only company to have expanded the stacking rack pallet system to the 75x246x149 cm size.

This has the following advantages:

- stacking optimises the use of space in warehouses.\*
- the 75 cm depth enables full use of container load space (3 pallets fit perfectly side by side). The vertical positioning of the product better protects the slabs during shipping.
- it facilitates work on site, since the slabs are already positioned vertically, making the material easy to inspect and remove for installation.
- the overall size of the rack pallet provides greater space for manoeuvring in the installation area in comparison with conventional crates, and also makes it easier to lift the slabs mechanically (with a crane or lift).
- the rack pallet system employs strapping which allows the user to remove a single package at a time without affecting the stability of the other packages on the pallet, thus minimising the risk of breakage. The slabs must be released from the packaging by reversing the packaging sequence, i.e. starting with the last package to have been strapped on.

### Cavalletto impilabile Stackable Rack pallet

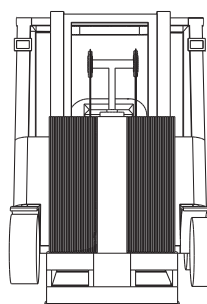
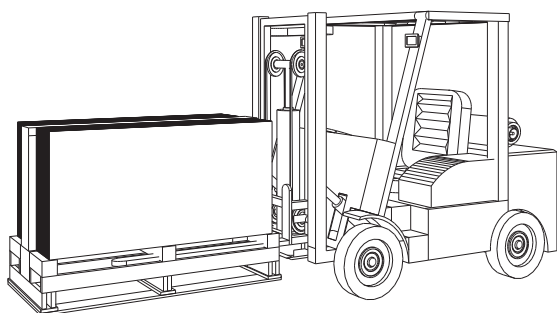
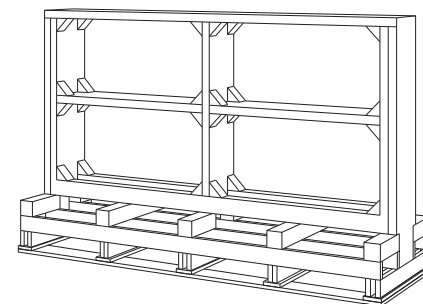
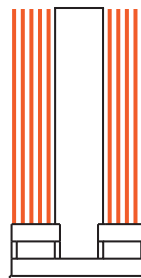

Modalità di trasporto consigliata per ottenere la massima visibilità.

Recommended transport system for maximum visibility.



\*Esempio di sovrapposizione del rack pallet con il formato 80x160.

\*Example of stacked rack pallets with the 80x160 cm size.

**Cassa**  
**Crate**  
Impilabile Stackable

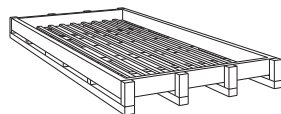

Ingombro Size 174x345x27,5  
(160x320 RETT/LUX)  
€ 130,00

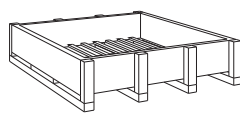

Ingombro Size 174x185x42,5  
(160x160 RETT/LUX)  
€ 90,00

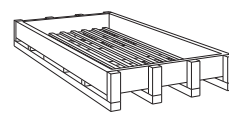

Ingombro Size 134x265x32  
(120x240 LUX)  
€ 100,00

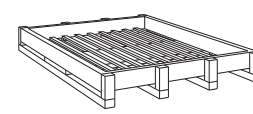

Ingombro Size 174x225x36  
(26x200 RETT)  
€ 40,00

**Cavalletto\***  
**Rack pallet\***  
Impilabile Stackable

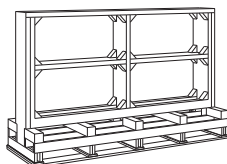
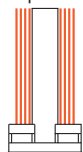

Ingombro Size 75x246x149  
(120x240 RETT)  
€ 120,00

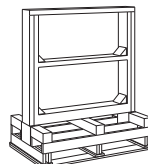

Ingombro Size 75x128x149  
(120x120 RETT)  
€ 50,00

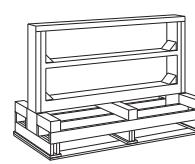

Ingombro Size 75x168x109  
(80x160 RETT)  
€ 50,00

**Cavalletto per containers**  
**Rack pallet for containers**  
Non impilabile Not stackable

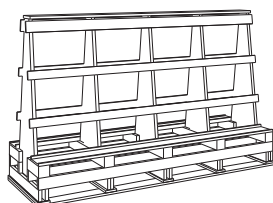
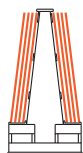

Ingombro Size 75x330x201  
(160x320 RETT/LUX)  
€ 235,00



Ingombro Size 75x170x201  
(160x160 RETT/LUX)  
€ 170,00

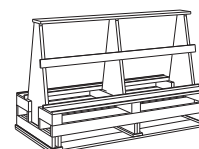

Ingombro Size 75x250x161  
(120x240 RETT/LUX)  
€ 190,00

**Pallet con sponde**  
**Pallet with sides**  
Impilabile Stackable

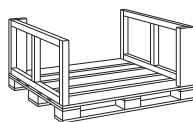
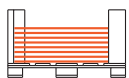

Ingombro Size 122x143x70  
(120x120 LUX)

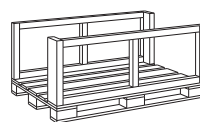

Ingombro Size 99x162x70  
(80x160 LUX)

**Europallet**  
Impilabile Stackable

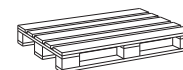

Ingombro Size 80x120x15  
(80x80 RETT/LUX - 20x120 RETT)

Per una corretta movimentazione di casse, cavalletti e pallet si raccomanda l'utilizzo di un carrello elevatore a forche con lunghezza di almeno 2,5 mt e con il posizionamento nella massima larghezza.

Top handle crates, rack pallets and pallets properly, use a lift truck with at least 2.5 m forks at their maximum width.

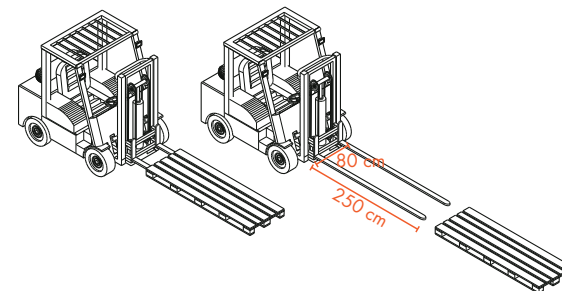
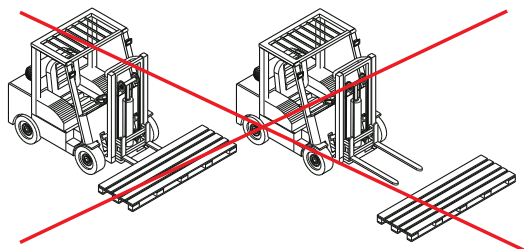

### POSA MOVIMENTAZIONE DELLE LASTRE

Durante le verifiche preliminari sul cantiere è opportuno accertare anche la possibilità di movimentare facilmente le lastre all'interno dei locali di posa. Tutti i formati che superano i 100 cm sia di lunghezza che di larghezza devono essere maneggiati da 2 posatori. Per una corretta gestione delle lastre, a partire dalla fase di apertura degli imballi, è necessario avvalersi di dispositivi idonei per la movimentazione.

Per la movimentazione manuale e la successiva posa in opera delle lastre WIDE 160x320, al fine di garantire la sicurezza per gli operatori e l'integrità del materiale, è vivamente consigliato l'utilizzo di barre di movimentazione con ventose. **1**

Per gli altri formati WIDE inferiori può essere sufficiente l'utilizzo delle sole ventose, anche in relazione allo spessore di 7 mm, che da una maggiore resistenza al prodotto. **2**

Gli appositi carrelli di movimentazione sono ideali sul cantiere come "magazzino" per una o più lastre, oltre che per effettuare in totale sicurezza l'operazione di spalmatura dell'adesivo sul retro della lastra. **3**

### LAYING HANDLING THE SLABS

When performing a preparatory inspection of the site, it is important to check whether the slabs can be handled easily in the installation area. All sizes in excess of 100 cm in either direction must be handled by 2 installers. Always use proper handling equipment to handle the slabs, from unpacking onwards.

When handling and laying WIDE 160x320 cm slabs by hand, use handling bars with suction cups to safeguard both the material and the installers themselves. **1**

For smaller WIDE sizes, it may be sufficient to use just suction cups, especially given that the product is 7 mm thick and therefore quite robust. **2**

Handling carts are ideally suited for holding slabs on site as well as for applying the adhesive to the back of the slab in total safety. **3**



### TAGLIO DELLE LASTRE

È opportuno effettuare le operazioni di taglio su una superficie piana, stabile e planare. È consigliato l'utilizzo di guide da taglio professionali con carrello incisore. **4**

Una volta rimossa la lastra dall'imballo e posizionata sul piano di lavoro segnare alle due estremità la dimensione da asportare. Posizionare e bloccare la guida di taglio, tenendo conto della distanza del disco di taglio. **5**

Incidere le estremità della lastra per circa 5 cm spingendo il carrello di incisione dall'interno verso l'esterno, procedere poi con l'incisione della lastra avendo cura di esercitare una pressione ed un avanzamento del carrello costanti per tutta la lunghezza del taglio.

Traslare la lastra in modo da portare la linea di incisione al di fuori del piano di lavoro di circa 5/10 cm.

Rimuovere la guida di incisione ed iniziare l'operazione di troncatura posizionando l'apposita pinza in corrispondenza della linea incisa; esercitare una pressione leggera e progressiva verso il basso. Quest'operazione risulterà molto semplice in quanto i prodotti Wide sono privi di tensionature e per questo facilmente lavorabili. **6**

A questo punto si può procedere con la finitura, che dovrà essere effettuata utilizzando gli appositi tamponi diamantati o in alternativa mediante dischi resinosi abrasivi. **7/8**

### CUTTING THE SLABS

We recommend cutting the slabs on a flat, stable surface (table). Use professional cutting guides with a cutting slide. **4**

Remove the slab from its packaging and place it on the table, then mark the cut at both ends. Locate and lock the cutting guide (make sure to account for the cutting disk offset). **5**

Cut the ends of the slab by pushing the slide about 5 cm from the interior to the edge of the slab, then cut the slab in a single smooth, even stroke at constant pressure.

Slide the slab so that the cut line is about 5 to 10 cm beyond the edge of the table.

Remove the cutting guide and shear off the excess material with the clamp located at the cut line; exert gradual, light pressure downwards. This is made particularly easy by the fact that Wide products have no tensioning and are thus easy to work. **6**

You can now finish the slab using diamond pads or abrasive resin disks. **7/8**





### TAGLI A L/SCASSI/ FORI RETTANGOLARI

Una volta tracciata sulla lastra la porzione da asportare è opportuno eseguire, in corrispondenza del punto di congiunzione delle linee, fori di diametro 6/8 mm con foretti diamantati a umido o a secco. 9

Congiungere poi i fori mediante una smerigliatrice angolare equipaggiata con disco diamantato (diametro max. 125 mm) 10

### CUTS L CUTS / RECESSED CUTS / RECTANGULAR HOLES

Once you have marked the cut on the slab, drill through the corners of the cut with a dry or wet 6 or 8 mm diamond bit. 9

Now join up the holes with an angle grinder fitted with a diamond disk (maximum dia. 125 mm) 10



# WIDE

## SUPERSIZE SLABS

### INCOLLAGGIO

Le lastre WIDE richiedono l'utilizzo della tecnica a doppia spalmatura, ovvero il collante dev'essere applicato sia sul fondo di posa che sul retro della lastra. **11**

Si consiglia l'utilizzo di adesivo in polvere a base cementizia a letto pieno di classe C2F (E) S1 /S2 come Baulite S2 di Hardkoll. **12**

Assicurarsi che la superficie da rivestire sia consistente, planare, priva di polvere e di unti/grassi, così come è bene rimuovere le polveri che possono trovarsi a contatto delle lastre. Stendere il collante sulla superficie da rivestire con spatola a denti inclinati con dente minimo di 8mm con movimenti lineari e mai circolari.

Stendere il collante sul retro della lastra con spatola dentata mai inferiore a 5 mm (tenendo conto che la somma delle spatole utilizzate per sottofondo e lastra dev'essere compresa fra i 13 e i 14mm).

Per garantire la perfetta posa dei prodotti WIDE occorre far defluire per vibrazione le bolle d'aria che si possono formare fra la lastra e l'adesivo fino a ottenere il "letto pieno" di collante. Per fare ciò è consigliabile avvalersi di un battitore manuale in gomma oppure utilizzare gli appositi dispositivi elettrici batti-piastrelle. **13/14**

In relazione al grande formato è consigliato l'utilizzo di distanziali livellanti facendo attenzione che lo strato di adesivo fra lastra e massetto sia almeno di 4 mm, per evitare interruzioni nella massa adesiva. **15/16**

La fuga minima consigliata, in relazione alla posizione dei giunti di dilatazione, è di 2 mm. Nel caso di pareti e pavimenti a contatto, da posare entrambi con lastre ceramiche, è indispensabile rispettare questa larghezza minima per garantire un perfetto risultato nel tempo. A rivestimento è possibile realizzare fughe inferiori in base alle opportune verifiche tecniche da effettuarsi sul cantiere. Le fughe dovranno essere riempite per almeno i 2/3 dello spessore con l'apposito sigillante, pertanto occorre prestare attenzione all'eventuale presenza di residui di adesivo all'interno.

### GLUING

WIDE slabs must be back-buttered; in other words, the adhesive must be applied both to the substrate and the back of the slab. **11**

We recommend using a cement-based full bonding powder adhesive, Class C2F (E) S1/S2, such as Hardkoll Baulite S2. **12**

Make sure the surface is stable, flat, clear of grease and dust, and also wipe off any dust on the back of the slab.

Apply the adhesive to the surface with an angled tooth trowel (at least 8 mm), in a linear motion (never in circles).

Apply the adhesive to the back of the slab with a toothed trowel (at least 5 mm); note that the sum of the trowel sizes used for the slab and substrate must be 13 - 14 mm.

To ensure perfect installation of WIDE products, use vibration to eliminate any bubbles between the slab and the adhesive to obtain a full bonding effect. Use either a rubber mallet or electric tile vibrator for this purpose. **13/14**

When installing large sizes, we recommend using levelling spacers; the layer of adhesive between the slab and the substrate must be at least 4 mm thick to ensure continuity. **15/16**

The expansion joint between slabs should be at least 2 mm wide. For contact walls and floors, both installed with ceramic slabs, this minimum dimension must be used to ensure a long-lasting result. A smaller joint width is possible when installing walls, following technical inspection on site. The joints must be filled to at least 2/3 of their depth with sealant; take care to remove all adhesive from the joint first.



# AUTO-LEVELING™

 **Facile installazione - Easy laying**

## CARATTERISTICHE

Auto-Leveling garantisce la massima facilità di posa ai listoni di grande formato. La tecnologia si basa sull'impiego di impasti a base di materie prime per loro natura altamente stabili e resistenti, ma al tempo stesso ad elevata plasticità, che conferiscono a questa tipologia di prodotti qualità uniche. Il materiale ottenuto, caratterizzato da un minimo grado di convessità, aderisce perfettamente al massetto. Una volta posata, la piastrella si auto-livella, mantenendo una perfetta planarità. La tecnologia Auto-Leveling si applica alle lastre ceramiche nei formati 20x170 e 40x170 cm (sp9mm).

## CHARACTERISTICS

Auto-Leveling guarantees the maximum ease of installation for large-format planks. The technology uses raw materials that combine stability and strength with high plasticity, giving unique qualities to this type of product. The resultant tiles have a small degree of convexity and bond perfectly to the screed. Once installed, the tiles self-level and maintain perfect flatness. Auto-Leveling technology is used for ceramic tiles in sizes 20x170 cm and 40x170 cm (thickness 9mm).



Lastre prodotte con materie prime ad elevata plasticità, resistenti ma flessibili.

Ceramic slabs manufactured with highly plastic raw materials, strong and flexible at the same time.



Appoggiate su qualsiasi superficie, anche non perfettamente planare, le lastre si auto-livellano.

Laid on the screed they self-level, even if the surface is not perfectly flat.

50% **OK**

Il prodotto auto-leveling agevola la posa tradizionale, si monta senza distanziali livellanti, seguendo qualsiasi schema di posa.

Auto-leveling tiles help the traditional fixing, every installation pattern can be achieved, without leveling spacers.

indicatore di flessibilità flexibility index	deflessione massima sotto carico di 350 N maximum deflection under load of 350 N	lato/length 1200 mm	> 20 mm
		lato/length 1700 mm	> 30 mm

## POSA A COLLA (formati rettificati 20x120-20x170-40x170)

Le lastre Auto-Leveling ABK sono in grado di riprodurre molte delle qualità tipiche dei pavimenti in legno. Anche in fase di posa è opportuno cercare di ottenere il massimo risultato estetico possibile, nel pieno rispetto delle norme che tutelano la conformità dei pavimenti ceramici. E' possibile mantenere una fuga minima di 0,5mm avendo cura di rispettare una distanza di 5mm dalle pareti perimetrali. La posa con fuga minima 0,5mm è consigliabile in ambienti non superiori ai 50 mq e si raccomanda in ogni caso di rispettare i giunti di dilatazione previsti nel massetto. Per la realizzazione della fuga minima, ABK consiglia l'utilizzo del sistema di posa MLT System, l'unico che permette di ridurre la fuga garantendo una perfetta planarità anche in condizioni non ottimali del massetto.

## INSTALLATION OF PRODUCTS (rectified tiles 20x120-20x170-40x170)

ABK Auto-Leveling tile slabs reproduce most of the typical features of wood floors. They should be installed with a view to attaining the best possible aesthetic result, while fully complying with the ceramic flooring stability standards.

Minimum grout joints of 0,5mm can be achieved, as long as a distance of 5 mm from the perimetral walls is kept. A minimum joint of 0.5mm is recommended for rooms under 50m<sup>2</sup>. In any case, the expansion joints required for the total screed area should be taken into account. To achieve a minimum grout joint width, as an alternative to "do it yourself" spacers (e.g. plastic straps), ABK highly recommends using the MLT installation system, the only one that can reduce joint thickness while ensuring perfect surface flatness, even when the screed is not in optimal condition.



Kit per la posa livellante composto da utensile professionale, piattelli di consumo, tiranti e basi riutilizzabili.

Tile levelling kit composed of a professional tool, single-use bottom plates, reusable straps and caps.



Posizionare piattello e tirante sotto alle piastrelle.

Place cap and straps under the tiles.



Inserire la base spingendola bene fino al contatto con le piastrelle.

Insert cap and push until it comes into contact with the tiles.



Tensionare con l'apposito utensile per poi rimuovere basi e tiranti una volta trascorso il tempo di indurimento della colla.

Tighten using the special tool and then remove caps and tie rods once the adhesive is properly set.

Per ulteriori informazioni [www.mltsystem.it](http://www.mltsystem.it) - For further information: [www.mltsystem.it](http://www.mltsystem.it)



# INSTA-TILE

## ↓ DRY FIXING

Le lastre Auto-Leveling nel formato 20x170 possono essere montate seguendo il sistema Insta-Tile, un nuovo metodo di posa a secco che consiste nel fissaggio del materiale direttamente sul pavimento preesistente, senza alcuna opera di demolizione. Dopo aver steso un tappetino in sughero o polietilene dello spessore di circa 2 mm, si consiglia di posizionare una serie di distanziali di 5 mm lungo tutte le pareti interessate per poi proseguire con la posa delle piastrelle, a giunto unito, praticando tutti i tagli necessari fino a coprire completamente il vecchio pavimento. Per contenere le dilatazioni si consiglia di applicare qualche goccia di silicone lungo il perimetro, per poi rimuovere i distanziali e procedere con l'inserimento del profilo o del battiscopa. Il nuovo pavimento, la cui superficie risulterà perfettamente planare anche senza l'utilizzo di colle e sigillanti e potrà facilmente essere rimosso e recuperato in qualsiasi momento.

Our 20x170 auto-leveling slabs can be laid using the Insta-Tile system, which is a new dry-fixing method that consists in laying the tiles directly on top of the existing floor, without any scrapping or removal work. After laying an approximately 2 mm thick cork or polyethylene underlayer, we recommend you fit a series of 5 mm spacers along all the perimeter before laying the tiles. The tiles should be laid with a closed joint and cut where necessary to completely cover the old floor. To limit expansion, it is recommended to apply a few drops of silicon around the outer edge, then remove the spacers and fit the edge trim or the skirting. The new floor, whose surface should be perfectly flat even without the use of glues or sealants, can be removed and re-used at any time.



Installazione prevista esclusivamente con prodotti AUTO-LEVELING nel formato 20x170.

You should use AUTO-ONLY products in the 20x170 size.



Installazione adatta unicamente ad ambienti INDOOR.

This system can be used for INDOORS installation only.



Si sconsiglia l'utilizzo di INSTA-TILE negli ambienti maggiormente umidi o sporchevoli, come bagno e cucina.

INSTA-TILE is not recommended in wet or easily dirtied areas, such as bathrooms and kitchens.



Il metodo INSTA-TILE permette di stendere le lastre senza alcuna fuga.

AUTO-LEVELLING tiles can be installed with close joints.



L'applicazione può avvenire in diverse situazioni:

- su massetto in cemento
  - su massetto in cemento con impianto di riscaldamento
  - su pavimento preesistente in ceramica, legno o linoleum
  - su pavimento preesistente con impianto di riscaldamento
- In tutti questi casi dev'essere utilizzato un materassino in sughero o in polietilene su cui stendere le lastre.

È possibile direttamente su moquettes di basso spessore senza l'ausilio del materassino.

It can be laid in different solutions:

- on top of cement screeds,
- on top of cement screeds with heating systems
- on top of existing ceramic, wooden or linoleum floorings
- on top of existing floorings with heating systems

In all these cases, a cork or polyethylene underflooring must be used. The planks can also be laid directly on top of short-pile carpet, without needing the underflooring.



Il pavimento INSTA-TILE si può pulire con normali detergenti, utilizzando regolarmente il panno bagnato ed i vari sistemi mop.

Nel caso di versamento importante di liquidi, sollevare le lastre ceramiche nella zona interessata aiutandosi con una ventosa, asciugare o sostituire la porzione del materassino sottostante e ri-posizionare le piastrelle.

INSTA-TILE flooring can be cleaned with normal cleaning detergents, using a wet cloth or a traditional mop.

In the event of major spills, lift up the ceramic tiles in the affected area using a suction cup, dry or replace the area of underflooring below and refit the tiles.



Si sconsiglia l'utilizzo di INSTA-TILE in presenza di animali domestici.

We do not recommend use of the INSTA-TILE system in homes with pets.

## OPERAZIONI DI POSA INSTA-TILE INSTA-TILE LAYING PROCESS



1  
Eliminare il battiscopa  
Remove skirting



2  
Stendere il tappetino  
Lay the underlayer



3  
Posizionare i distanziali lungo il perimetro  
Fit the spacers around the outer edge



4  
Posare il pavimento senza fuga  
Lay the floor tiles with close joints



5  
La superficie risulterà perfettamente planare  
The finished floor will be perfectly flat

Il pavimento Insta-Tile, nel periodo immediatamente successivo all'installazione, può manifestare un leggero effetto di scricchiolio dovuto al contatto delle piastrelle accostate senza fuga con il passaggio prolungato si attenuerà progressivamente fino a scomparire. Per evitare fin da subito questo fenomeno si può interporre un normale foglio di carta tra una piastrella e l'altra in fase di posa, creando una micro fuga di circa 0,2 mm che previene ogni rumore da sfregamento.

The Insta-Tile floor, in the period right after the installation, can produce a slight crunch noise due to the contact of the tiles laid without joint. This noise will gradually diminish until it will disappear after a while with the traffic on the floor. To avoid this noise since the beginning a normal paper sheet can be interposed between the tiles in the laying stage, creating a micro joint of about 0.2 mm which prevents any noise from rubbing.

## ACCESSORI PER POSA A SECCO INSTA-TILE ACCESSORY FOR DRY FIXING INSTA-TILE

### TAPPETINI PER SOTTOPAVIMENTO IN ROTOLO

Codice Code	Misura Size	Prezzo Price	imb.	confezione packaging
TPPOL1X	TAPPETO POLIETILENE ANTRACITE 2,5 mm rotolo dimensione 1,50x25,00 m	11,50 / mq	1	rotolo da 37,5 mq
TPPSUG1X	TAPPETO SUGHERO NATURALE 2 mm rotolo dimensione 1,00x30,00 m	10,50 / mq	1	rotolo da 30 mq



Tappeto polietilene  
antracite 2,5 mm



Tappeto sughero  
naturale 2 mm

### ELEMENTI DI FINITURA

Codice Code	Misura Size	Prezzo Price	imb.	confezione packaging
RACALL1X	RACCORDO ALLUMINIO ANODIZZ. PAVIMENTO/PARETE barra di lunghezza 1,20 m - h = 4,5 mm	14,70 / pz	5	scatola da 5 pz
TERALL1X	TERMINALE di DISLIVELLO ALLUMINIO ANODIZZ. barra di lunghezza 1,20 m - h = 11 mm	17,30 / pz	5	scatola da 5 pz
PRFALL1X	PROFILO di DISLIVELLO ALLUMINIO ANODIZZ. barra di lunghezza 1,20 m - h = 10 mm	18,00 / pz	5	scatola da 5 pz



Raccordo pavimento/parete

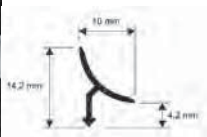

Terminale di dislivello

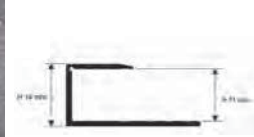

Profilo di dislivello



## CARATTERISTICHE

Wall&Porcelain nasce come evoluzione della ceramica da rivestimento tradizionale e allo stesso tempo riprende qualità tipiche del gres porcellanato, pur senza averne i limiti. È possibile produrre in W&P lastre ceramiche rettificate di grande formato, fino a 60x120 cm (tecnicamente non realizzabili in bicottura o monoporosa), leggere, maneggevoli, sottili (7 mm) e perfettamente planari, più facili da posare, lavorare e tagliare rispetto al gres, pratiche come i rivestimenti classici, ma inalterabili nel tempo e senza difetti post posa. W&P, oltre ad unire qualità tecniche di prodotto e praticità d'uso, incontra il design e permette di realizzare proposte sempre nuove e diversificate, in linea con le ultime tendenze e facilmente coordinabili con i pavimenti in gamma. Ispirazioni che spaziano dai wallpaper, fino alle superfici strutturate e 3D, per utilizzi molto diversi, ideali per la progettazione di tutti gli ambienti interni.

## CHARACTERISTICS

Wall&Porcelain combines the qualities of conventional ceramic wall tiles with those of porcelain tiles while avoiding their respective limitations. W&P can be used to produce large-format rectified ceramic panels up to 60x120 cm in size (not technically possible for double-fired or monoporosa tiles). These panels are lightweight, thin (7 mm), easy to handle and perfectly flat. They are easier to install, work with and cut than porcelain and are just as practical as conventional wall tiles while also being supremely durable and free of post-installation defects. But along with technical qualities and practicality of use, W&P also attains a high level of design and can create ever new and diversified offerings that follow the latest trends and coordinate easily with the floor tiles in the range. The tiles draw inspiration from a range of sources including wallpapers and textured and 3D surfaces and are suitable for all interior applications.



### GRANDE FORMATO, BASSO SPESSORE

La tecnologia Wall&Porcelain, a differenza della monoporosa tradizionale, permette di produrre lastre ceramiche rettificate monocoloro di grandi dimensioni e dallo spessore ridotto.

### BIG SIZE, THIN THICKNESS

The technology Wall&Porcelain, unlike traditional mono-porous, allow to produce ceramic slabs rectified mono-caliber in big sizes and reduced thickness.



### ELASTICITÀ

Wall&Porcelain garantisce una maggiore aderenza alle superfici mantenendo una perfetta planarità.

### ELASTICITY

Wall&Porcelain ensures greater adherence to surfaces while maintaining a perfect flatness.



### RESISTENZA

Le superfici risultano resistenti, come quelle del gres.

### RESISTANCE

The surfaces are resistant, like porcelain stoneware ones.



### LEGGEREZZA

Il peso ridotto, rispetto al gres tradizionale, rende il prodotto più maneggevole.

### LIGHTWEIGHT

The light weight compared to traditional porcelain stoneware makes this product easy to handle.



### PRATICITÀ

Wall&Porcelain è un materiale incredibilmente facile da tagliare e da lavorare.

### PRACTICALITY

Wall&Porcelain is a material incredibly easy to cut and process.







#### AFFIDABILITÀ

È immune dal problema delle micro fessurazioni superficiali che possono presentarsi nel post posa (cavillo tardivo).

#### RELIABILITY

It is immune to the problem of superficial micro-cracks that may occur after the installation (after-laying crazing).



#### COMFORT

Offre un isolamento termico ed acustico superiore rispetto a quello del gres.

#### COMFORT

It offers greater thermal and acoustic insulation compared to porcelain stoneware.



#### INTELLIGENTE

È realizzato con lo speciale impasto ECO-BODY, contenente il 40% di materie prime recuperate da altre lavorazioni industriali.

#### INTELLIGENCE

It is produced with the special ECO-BODY mix that contains 40% of raw material recovered from other industrial processes.



#### ECO-SOSTENIBILE

È rettificato a secco, con un minor consumo di energia e un totale recupero degli scarti di lavorazione.

#### ECO-SUSTAINABILITY

A dry straight edge cutting system is used with reduced energy consumption and total recovery of processing waste.

INDICATORE DI FLESSIBILITÀ FLEXIBILITY INDEX	DEFLESSIONE MASSIMA SOTTO CARICO DI 200 N RELATIVAMENTE AL LATO 1200 mm MAXIMUM DEFLECTION UNDER LOAD OF 200 N, RELATED TO 1200 mm LENGTH	> 20 mm
---	--	---------

### POSA (formati rettificati 30x120-60x120)

Le lastre da rivestimento Wall&Porcelain ABK, nelle diverse espressioni estetiche proposte a catalogo, sono studiate per offrire un effetto visivo di massima continuità tra un pezzo e l'altro. Per ottenere un risultato impeccabile e garantire l'affidabilità del materiale posato, Abk raccomanda di mantenere tra una piastrella e l'altra una fuga minima che consentirà ai sigillanti di penetrare e aderire perfettamente sia al materiale ceramico che alla parete avendo cura di rispettare gli eventuali giunti presenti. Per la realizzazione della fuga minima, ABK consiglia l'utilizzo del sistema di posa MLT system che oltre a garantire il perfetto allineamento delle lastre, garantisce una fuga minima di 0.5 mm, ottenuta grazie allo speciale tirante riutilizzabile della serie "Slim".

### INSTALLATION (rectified sizes 30x120-60x120)

ABK Wall&Porcelain tile slabs - available in the catalogue a range of different moods and styles - are specifically designed to ensure maximum visual continuity between tiles. To achieve flawless results and maximum tiling reliability, ABK recommends a minimum joint width is provided to enable sealants to penetrate and adhere perfectly to the ceramic tile and the wall respecting the expansion joint. In this respect, as an alternative to "do it yourself" spacers (e.g. plastic straps) or traditional plastic wedges, ABK recommends using the MLT installation system to ensure perfect tile alignment and achieve a minimum joint width of 0.5 mm, with the special "Slim" range reusable strap.



Wall&Porcelain è un gres poroso, pertanto non necessita della doppia spalmatura di colla.

Wall&Porcelain stoneware tile slabs feature a porous body and as such, do not require a double layer of adhesive.



Cunei per la posa dei rivestimenti in materie sintetiche.

Wedges (made of synthetic material) for wall tile installation.



Tirante realizzato in nylon e acciaio inossidabile. Riutilizzabile centinaia di volte.

Special nylon and stainless steel strap. Can be used hundreds of times.

# OUT. 20<sup>20 mm</sup>



**POSA TRADIZIONALE**  
la posa tradizionale è ideale per la realizzazione di pavimentazioni carrabili.

**TRADITIONAL INSTALLATION**  
traditional installation is ideal for floorings that will be driven over by vehicles.



**POSA A SECCO SU GHIAIA**  
La posa su ghiaia permette il perfetto drenaggio delle acque piovane.

**DRY INSTALLATION ON GRAVEL**  
Installing on gravel enables perfect drainage of rainwater.



**POSA A SECCO SU ERBA**  
La posa diretta su erba permette di creare percorsi e camminamenti integrandosi perfettamente nell'ambiente.

**DRY INSTALLATION ON GRASS**  
Installing directly on top of grass enables the creation of paths and walkways that blend in perfectly with the surroundings.



**POSA A SECCO SU SABBIA**  
La posa su sabbia permette di creare percorsi e camminamenti per spiagge e stabilimenti balneari.

**DRY INSTALLATION ON SAND**  
Installing on top of sand is ideal for creating paths and walkways on beaches and beach bars.



## POSA SOPRAELEVATA DA ESTERNO

Il sistema di pavimentazione sopraelevata prevede l'utilizzo di supporti portanti di tipo autolivellante, regolabili oppure fissi che si adattano con semplicità e sicurezza ad ogni tipo di pavimento sottostante. Il sistema permette la realizzazione di piani di posa con altezze variabili, da terra, comprese fra 25 e 270 mm. L'indipendenza della pavimentazione dai supporti garantisce l'assorbimento di eventuali movimenti strutturali. Il sistema sopraelevato non necessita di massetto in cemento e consente una diminuzione del peso sulla struttura portante. Le fughe aperte tra una piastrina ed un'altra consentono un facile deflusso dell'acqua piovana evitando tutti i rischi di accumulo o di ristagno. La presenza dell'intercapedine fra il piano di calpestio e il piano di appoggio favorisce l'aerazione e l'isolamento termico. Questa soluzione permette inoltre il passaggio di impianti e tubazioni nell'intercapedine, e la facile ispezione degli stessi una volta installata la pavimentazione.

## OUTDOOR RAISED LAYING SYSTEM

The raised floor system foresees the use of self-levelling, adjustable or fixed load bearing supports that easily adapt to the floor below in total safety. The system is suitable to create laying designs with variable heights from the ground, which range between 25 and 270 mm. The independence of the flooring from the supports guarantees the absorption of any structural movements. The raised system does not require a cement screed and reduces the load on the bearing structure. The open joints between the tiles allow rainwater to easily drain off, avoiding any risk of water accumulation or stagnation. The gap between the tread surface and the support surface favours ventilation and heat insulation. This solution allows for the installation of systems and piping in the gap, which can be easily inspected even once the floor has been installed.

## SUPPORTI PER LA POSA SOPRAELEVATA / SUPPORTS FOR RAISED LAYING SYSTEM

### SRA SUPPORTO AUTOLIVELLANTE REGOLABILE CON TESTA IN BIMATERIALE (pp+gomma)

#### VANTAGGI

- Testa autolivellante che compensa automaticamente pendenze fino al 5%;
- Regolabile da 37,5 a 215mm con pavimento finito grazie all'esclusiva chiave di regolazione;
- Base di appoggio liscia di 320cm<sup>2</sup>;

### ADJUSTABLE PAVING SUPPORT WITH SELF-LEVELLING BI-MATERIAL HEAD

#### ADVANTAGES

- Selflevelling head that automatically justify slopes to 5%;
- Adjustable height from 37,5 to 215mm once pavement is finished thanks to exclusive regulation key
- 320 cm<sup>2</sup> smooth base support

Codice Code	Misura Size	Prezzo Price	imb.	u.m.	peso / weight Kg.
SRA0038X	28-38 mm	7,80	1	pz	0,270
SRA0050X	37,5-50 mm	8,20	1	pz	0,340
SRA0075X	50-75 mm	8,70	1	pz	0,380
SRA0120X	75-120 mm	9,60	1	pz	0,490
SRA0170X	120-170 mm	10,20	1	pz	0,560
SRA0215X	170-215 mm	10,50	1	pz	0,648



- 1 Chiave di regolazione. / Adjustment key.
- 2 Alette preincise. / Pre-cut tabs.
- 3 Testa autolivellante gomma anti-rumore e anti-scivolamento / Selflevelling head rubber anti-noise and anti-slip
- 4 Aggancio testa-vite / Coupling head to screw attachment system
- 5 Vite / Screw
- 6 Sistema di blocco / Block System
- 7 Fori scarico acqua / Water drainage holes
- 8 Base di appoggio / Supporting base

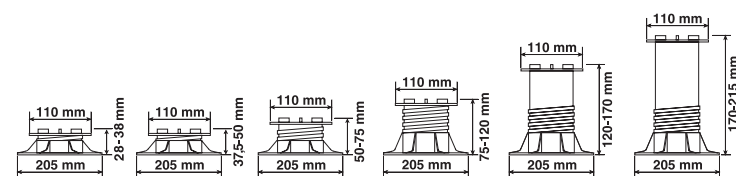

SRA0038X	SRA0050X	SRA0075X	SRA0120X	SRA0170X	SRA0215X
28 - 38 mm	37,5 - 50 mm	50 - 75 mm	75 - 120 mm	120 - 170 mm	170 - 215 mm

## SRF SUPPORTO REGOLABILE CON TESTA IN BIMATERIALE (pp+gomma)

### VANTAGGI

- Regolazione millimetrica da 25 a 270 mm;
- Regolazione dell'altezza, a pavimento finito, grazie all'esclusiva chiave di regolazione;
- Testa con parte superiore in gomma antirumore ed antiscivolo;
- Base di appoggio liscia di 320 cm<sup>2</sup>;
- Resistente agli agenti atmosferici, agli acidi, all'invecchiamento, ai raggi UV;
- Resistente a temperature fra -40° e +120°C;
- Totalmente riciclabile;
- Utilizzabile con qualsiasi pavimentazione da esterno;
- Alette facilmente asportabili.



- 1 Chiave di regolazione / Adjustment key
- 2 Alette preincise / Pre-cut tabs
- 3 Testa autolivellante gomma anti-rumore e anti-scivolo / Self-levelling head + rubber anti-noise and anti-slip
- 4 Aggancio testa-vite / Coupling head to screw attachment system
- 5 Vite / Screw
- 6 Sistema di blocco / Block System
- 7 Fori scarico acqua / Water drainage holes
- 8 Base di appoggio / Supporting base

## SRB BASIC SUPPORTO REGOLABILE

### VANTAGGI

- Regolazione millimetrica da 27 a 120 mm
- Regolazione dell'altezza agendo direttamente sulla base
- Base di appoggio liscia di 320 cm<sup>2</sup>



- 1 Testa/vite con alette standard spessore 4 mm, H12mm, su richiesta:
    - testa liscia
    - Alette spessore 2 mm- H10 mm
    - Alette spessore 3,5 mm - H18 mm
  - 2 Alette preincise / Pre-cut tabs
  - 3 Base di appoggio / Supporting base
- Head/screw with standard 4 mm thick tabs, H12mm. On request:
- flat head
  - 2 mm thick tabs - H10 mm
  - 3,5 mm thick tabs - H18 mm

## CONSUMO / USAGE

Piastra Tiles	Posa lineare Linear laying	Posa alternata Alternative laying
40x80 / 16"x32"	3,12 pz/m <sup>2</sup>	6,24 pz/m <sup>2</sup>
30x120 / 12"x48"	5,6 pz/m <sup>2</sup>	5,6 pz/m <sup>2</sup>

N.B il calcolo non tiene in considerazione lo sfido generato dal perimetro.  
N.B the calculation does not take into consideration the waste generated by the perimeter.

## ADJUSTABLE PAVING SUPPORT WITH BI-MATERIAL HEAD

### ADVANTAGES

- Precision adjustment from 25 to 270 mm
- Possibility of adjusting the height once the floor has been finished, thanks to the exclusive adjustment wrench
- End with upper part in noise-reducing anti-slip rubber
- Smooth support base of 320 cm<sup>2</sup>
- Resistant to weathering, acids, UV rays and wear and tear.
- Resistant to temperatures ranging from -40 °C to +120°C.
- Fully recyclable
- Can be used in conjunction with any outdoor flooring
- Easily removable tabs

Codice Code	Misura Size	Prezzo Price	imb.	u.m.	peso / weight Kg.
SRF0040X	25-40 mm	4,70	1	pz	0,243
SRF0070X	40-70 mm	5,30	1	pz	0,308
SRF0100X	60-100 mm	6,00	1	pz	0,379
SRF0160X	90-160 mm	7,50	1	pz	0,402
SRF0270X	150-270 mm	10,30	1	pz	0,666

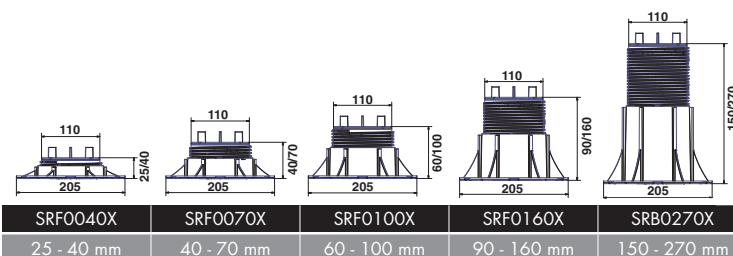

## ADJUSTABLE PAVING SUPPORT

### ADVANTAGES

- Precision adjustment from 27 to 120 mm
- Possibility of adjusting the height by acting directly upon the base
- Smooth support base of 320 cm<sup>2</sup>

Codice Code	Misura Size	Prezzo Price	imb.	u.m.	peso / weight Kg.
SRB0035X	27-35 mm	4,20	1	pz	0,200
SRB0050X	35-50 mm	4,40	1	pz	0,210
SRB0080X	50-80 mm	4,90	1	pz	0,228
SRB0120X	70-120 mm	5,30	1	pz	0,280

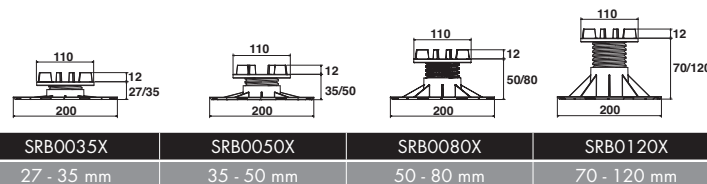



## SISTEMI PER FACCIATE VENTILATE / SYSTEMS FOR VENTILATED FAÇADES

La gamma in gres porcellanato di ABK, per le qualità tecniche ed estetiche, a cui oggi si aggiunge la disponibilità di nuovi grandi formati, è in grado di soddisfare a 360° le esigenze specifiche dell'architettura, tra cui la progettazione e la realizzazione di facciate ventilate.

ABK collabora con imprese specializzate nella produzione dei principali sistemi di fissaggio, fornendo l'assistenza tecnica necessaria, a partire dalla fase iniziale del progetto sino alla posa in opera.

ABK's porcelain tile range, with its technical and aesthetic quality and its new range of large size slabs, provides a full spectrum of architectural solutions, including the design and installation of ventilated façades. ABK works with the major manufacturers of mounting systems, and provides technical assistance from the design stage through to installation.



### PRINCIPALI TIPOLOGIE DI FACCIATA / MAIN TYPES OF FAÇADE

Sistemi utilizzabili con i principali formati ABK: 40x80, 60x60, 30x120, 60x120, 120x240, 160x160, 160x320.

Systems compatible with the principal ABK slab sizes: 40x80, 60x60, 30x120, 60x120, 120x240, 160x160, 160x320.

#### SISTEMA DI AGGANCIO INVISIBILE PRE-ASSEMBLATO

La facciata ventilata è costituita da una sottostruttura formata da profili in alluminio EN AWW-6060, lavorati e pre-assemblati alla lastra secondo le linee ortogonali di progetto e adattata alle dimensioni delle lastre di finitura. Il pre-assemblaggio avviene utilizzando inserti con incastro a baionetta previa idonea foratura cieca sul retro della lastra di finitura; il serraggio degli inserti avverrà per mezzo di viti inox e i profili (dotati d'apposito alloggiamento) dovranno collaborare con le lastre di finitura utilizzando idonei collanti strutturali, al fine di aumentarne la resistenza e la messa in sicurezza delle lastre stesse. La sottostruttura sarà dotata di incastri con tolleranze di +/- 2/10 di mm, aventi la funzione di vincolare l'allineamento delle lastre e assicurare una dimensione costante e predeterminata delle fughe (con dimensioni da 0,5 a 8 mm), permettendo inoltre la riduzione a casellario in corso d'opera. I profili di sottostruttura saranno dotati di apposite guide per alloggiare il sistema di ancoraggio (staffa e gancio) puntuale a parete (laterizi, cemento armato o elementi strutturali portanti), la staffa e il gancio permetteranno il fissaggio sicuro e puntuale di ogni singola lastra. Le regolazioni micrometriche sui tre assi principali dovranno permettere allineamenti perfetti e consentire la realizzazione della complanarità fra le singole lastre, la posa pertanto sarà realizzata senza alcuna preparazione del supporto su cui la facciata ventilata sarà fissata. La sottostruttura pre-assemblata su lastra dovrà sormontare ed accoppiarsi alla sottostruttura della lastra che la precede, in tal modo la facciata verrà definita a giunto chiuso e potrà sostenere una camera a circolazione d'aria contenuta al minimo. Le fughe si presentano chiuse, onde evitare l'ingresso di insetti e acqua meteorica, potranno essere realizzate a "fuga zero" (0,5 mm reale) fermo restando le prestazioni di assorbimento delle dilatazioni che sono garantite dai micro giunti previsti dalla sottostruttura in alluminio.

#### CONCEALED PRE-ASSEMBLED MOUNTING SYSTEM

A ventilated façade is composed of an aluminium frame made of EN AWW-6060 profile members pre-assembled to the slabs along the perpendicular axes and adapted to the size of the finishing slabs. Pre-assembly employs bayonet mounting inserts which install to blind holes drilled into the back of the slab; the inserts are tightened to the slab with stainless steel screws and the profiles (with matching sockets) work together with the finishing slabs using structural adhesive to increase the strength and safety of the slabs themselves. The frame is equipped with joints with a tolerance of 2 to 10 mm, which align the slabs and ensure that the joints are of the specified constant width, allowing a grid pattern to be created during installation. The frame members are equipped with guides for the bracket and clip wall anchoring system (masonry, reinforced concrete or bearing members); the bracket/clip anchoring systems ensures secure mounting of each slab to the wall. The system can be adjusted micrometrically along all three axes to ensure perfect alignment and flatness, so that there is no need to prepare the wall itself prior to installation. The frame pre-assembled to each slab must fit over and couple with the frame of the preceding slab, so that the façade can be considered to be a closed joint structure capable of supporting a minimal air gap. The system can be installed with closed joints (actual width 0.5 mm) to prevent ingress of insects and rainwater. This does not affect the system's thermal expansion characteristics, which are provided by the micro-joints in the aluminium frame.

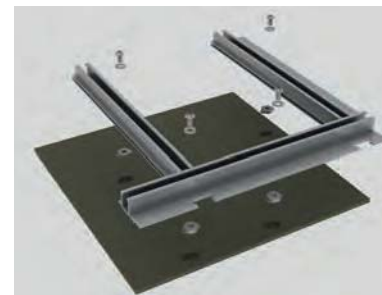
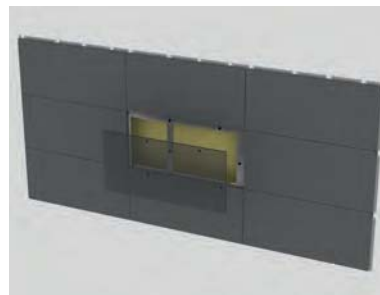
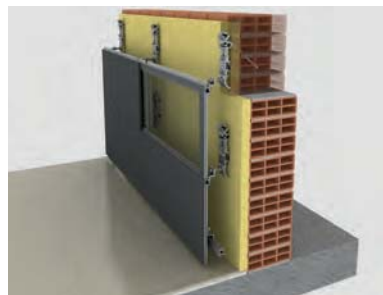
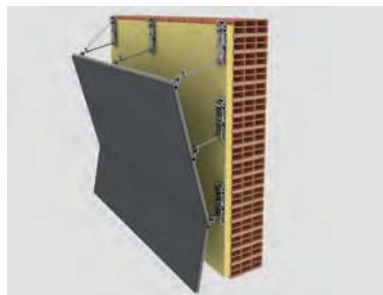

## SISTEMA DI AGGANCIAMENTO INVISIBILE

Questo sistema prevede una predisposizione delle lastre di rivestimento che consiste in una lavorazione meccanica da eseguire sullo spessore delle lastre (fresatura slot) ed il successivo inserimento di speciali inserti in acciaio che funzionano come molle. La struttura è composta da profili e staffe ricavati attraverso estrusione di lega di alluminio dello spessore minimo di 2 mm. La struttura sarà vincolata al supporto con particolari accorgimenti atti ad assorbire dilatazioni/ritiri termici e piccoli movimenti del supporto senza che il rivestimento esterno risenta di sollecitazioni indotte. La sicurezza del sistema nella sua completezza dovrà essere garantita attraverso una verifica, caso per caso, in funzione delle norme vigenti relative alla pressione e alla depressione del vento.

Il fissaggio delle staffe di supporto sottostante con sezione ad U, dovrà essere realizzato mediante tasselli opportunamente dimensionati e adatti alla tipologia specifica di supporto. Il fissaggio dei profili montanti sulle staffe sarà gestito attraverso rivetti, con "punto fisso" e "punto scorrevole", in funzione di quanto riportato nel progetto esecutivo. Sui profili montanti dovranno poi essere ancorati i profili correnti orizzontali assolati, sagomati in modo che gli sforzi dovuti all'azione del vento risultino assiali alle griffe. Questo sistema prevede una predisposizione delle lastre di rivestimento che consiste in una lavorazione meccanica da eseguire sul retro della lastra ed il successivo inserimento di speciali inserti in acciaio. Questa predisposizione è specificatamente studiata per l'ancoraggio delle griffe che saranno poi agganciate al profilo orizzontale.

## VOCE DI CAPITOLATO SOTTOSTRUTTURA

Fornitura di sottostruttura (fissaggi, staffaggi, profili e ancoraggi) come di seguito descritta e posa in opera di sottostruttura e lastre di rivestimento, con aggancio nascosto per lastre digres porcellanato.

Staffa a L in alluminio tipo Si80 ancorata al supporto murario con tasselli chimico composto da calza a rete in nylon, ancorate chimico, barr filettata M10, rondella 9x24 e dado M10.

Montante verticale con sezione a T, estruso in alluminio grezzo lega 6060 T5, lunghezza standard di 660 cm e/o sezione 110x80x2 mm, peso 1,43 kg/m, provvisto di asola verticale per non contrastare le proprie dilatazioni termiche.

Bulloneria di connessione staffa montante in acciaio zincato composta da bullone TE M6, rondella 6x18, rondella grower e dado M6. Collante di sicurezza.

Ganci S10, in acciaio Aisi 304, per fissaggio lastre nascosto.

## SISTEMA DI AGGANCIAMENTO A VISTA

La struttura è composta da profili e staffe ricavati attraverso estrusione di lega di alluminio dello spessore minimo di 2 mm. La struttura sarà vincolata al supporto con particolari accorgimenti atti ad assorbire dilatazioni/ritiri termici e piccoli movimenti del supporto senza che il rivestimento esterno risenta di sollecitazioni indotte. La sicurezza del sistema nella sua completezza dovrà essere garantita attraverso una verifica, caso per caso, in funzione delle norme vigenti relative alla pressione e alla depressione del vento.

Il fissaggio delle staffe di supporto sottostante con sezione ad U, dovrà essere realizzato mediante tasselli opportunamente dimensionati e adatti alla tipologia specifica di supporto. Sarà quindi possibile procedere al montaggio di un profilo sulle staffe attraverso rivetti con "punto fisso" e "punto scorrevole", in funzione di quanto riportato a progetto esecutivo. Nel profilo montante sono ricavate gole per alloggiare distanziatori e clips auto-posizionanti in acciaio inox, che possono essere di colore simile al tipo di rivestimento scelto. Il sistema sarà completato da guarnizioni EPDM che avranno funzione antivibrazione. Il sistema così composto potrà avere una fuga fra le lastre da 4 mm a 8 mm.

## VOCE DI CAPITOLATO SOTTOSTRUTTURA

Fornitura di sottostruttura (fissaggi, staffaggi, profili e ancoraggi) come di seguito descritta e posa in opera di sottostruttura e lastre di rivestimento, con aggancio mimetico a vista per lastre di gres porcellanato.

Staffa a L in alluminio con tasselli meccanici tipo M10x90 e/o tassello chimico composto da calza a rete nylon, ancorante chimico, barra filettata M10, rondella 9x24 e dado M10.

Montante verticale con sezione a T, estruso in alluminio grezzo lega 6060 T5, lunghezza standard di 660 cm e/o sezioni tagliate su misura, dim. sezione 110x80x2 mm, peso 1,43 Kg/m, provvisorio di asola verticale per non contrastare le proprie dilatazioni termiche.

Bulloneria di connessione staffa montante in acciaio zincato composta da bullone TE M6, rondella 6x18, rondella grower e dado M6. Collante di sicurezza.

Ganci AM2 - AM4, in acciaio Aisi 430 e colorati a polvere, per il fissaggio a vista della lastra di rivestimento. Colore RAL da definire in base alla lastra di rivestimento.

## CONCEALED MOUNTING SYSTEM

With this system the finishing slabs must be specially prepared by milling slots within their thickness and subsequently installing steel inserts that act as springs. The frame is composed of extruded aluminium profile members and brackets with a minimum thickness of at least 2 mm. The frame is mounted to the wall with equipment designed to handle thermal expansion cycles and small movements of the wall itself without transmitting stress to the slabs. The safety of the system as a whole is guaranteed by review of the local conditions as related to the regulations governing wind over- and underpressure.

The U-section mounting brackets are secured to the wall with anchor bolts suited to the load and wall material. The vertical members are secured to the brackets with rivets, with a fixed point and a sliding point, in accordance with the installation design. The slotted horizontal members are then anchored to the vertical members; the horizontal members are shaped to transmit the wind force axially to the clips. This system employs special steel inserts which are inserted into blind holes drilled into the back of the slabs. This solution is specifically designed to anchor the clips, which are then hooked onto the horizontal frame members.



## FAÇADE FRAME BILL OF MATERIALS

Supply of a frame (mounts, brackets, profile members and anchoring equipment) as described below and installation of frame and finishing slab, with concealed mounting system for porcelain tile slabs.

L-shaped Si80 aluminium bracket mounted to the wall with chemical anchors composed of a nylon mesh sheath, chemical anchoring agent, M10 threaded bar, 9x24 washer and M10 nut.

T-section vertical frame member (unfinished 6060 T5 aluminium extrusion), standard length 660 cm or custom length, cross-section 110x80x2 mm, weight 1.43 kg/m, with vertical thermal expansion slot.

Vertical member bracket fastening equipment composed of TE M6 bolt, 6x18 washer, split washer and M6 nut. Safety adhesive.

S10 clips in Aisi 304 stainless steel for mounting the slabs (concealed).

## EXPOSED MOUNTING SYSTEM

The frame is composed of extruded aluminium profile members and brackets with a minimum thickness of at least 2 mm. The frame is mounted to the wall with equipment designed to handle thermal expansion cycles and small movements of the wall itself without transmitting stress to the slabs. The safety of the system as a whole is guaranteed by review of the local conditions as related to the regulations governing wind over- and underpressure.

The U-section mounting brackets are secured to the wall with anchor bolts suited to the load and wall material. It is thus possible to install the frame member to the brackets with rivets in a fixed/sliding point system, as required by the installation design. The vertical members have slots for mounting stainless steel spacers and self-locating clips to support the finishing slabs. The system includes EPDM anti-vibration gaskets. This type of system has a joint between slabs of 4 to 8 mm.



## FAÇADE FRAME BILL OF MATERIALS

Supply of a frame (mounts, brackets, profile members and anchoring equipment) as described below and installation of frame and finishing slab, with exposed camouflaged mounting system for porcelain tile slabs.

L-shaped aluminium bracket with mechanical M10x90 anchor bolts or chemical anchor composed of nylon mesh sheath, chemical anchoring agent, M10 threaded bar, 9x24 washer and M10 nut.

T-section vertical frame member (unfinished 6060 T5 aluminium extrusion), standard length 660 cm, cross-section 110x80x2 mm, weight 1.43 kg/m, with vertical thermal expansion slot.

Vertical member bracket fastening equipment composed of TE M6 bolt, 6x18 washer, split washer and M6 nut. Safety adhesive.

AM2 - AM4 Aisi 430 stainless steel clips with powder coating, for exposed mounting of the wall slab. RAL colour to match the slab.

## AVVERTENZE GENERALI

Indipendentemente dal tipo di prodotto e formato scelto, prima di procedere con la posa è opportuno fare una verifica sul cantiere per valutare le condizioni dei sottofondi. La posa richiede le migliori condizioni del sottofondo. Che dovrà sempre essere:

- asciutto e stagionato
- pianare e privo di fessurazioni
- pulito, libero da polvere detriti o grumi di cemento
- compatto e resistente

La perfetta riuscita di un pavimento o di un rivestimento è il frutto della combinazione di molteplici fattori; per ottenere il migliore effetto estetico nella posa è opportuno ricordare che i prodotti ABK Group prevedono un numero variabile di pattern grafici, la cui successione all'interno delle scatole avviene in modo del tutto casuale.

## POSA DEI PRODOTTI RETTIFICATI

Per raggiungere un effetto ottimale ABK suggerisce di mantenere almeno 1 o 2 mm di fuga per una posa mono-formato e 2 o 3 mm per combinare formati misti nelle pose modulari suggerite dai cataloghi.

## POSA DEI PRODOTTI NON RETTIFICATI

L'alto grado di vitrificazione delle piastrelle ABK comporta modeste tolleranze di calibro, pertanto nella posa dei prodotti a bordo naturale è consigliabile lasciare una fuga di almeno 3 mm fra le piastrelle.

## OPERAZIONI PRELIMINARI

Una volta scelto il materiale da posare, coerentemente con i requisiti tecnici, lo stile e la destinazione d'uso degli ambienti, è bene seguire alcune raccomandazioni prima di procedere con l'installazione: stendere a terra almeno 3mq di prodotto per controllare l'effetto d'insieme, avendo cura di verificarne accuratamente calibro, tonalità e scelta.

Specie nel caso di prodotti con elevata variabilità grafica, è bene posare il materiale attingendo da più scatole, le variazioni grafiche e cromatiche del prodotto sono una caratteristica qualificante che l'abilità del posatore può valorizzare, al contrario un prodotto posato senza tenerne conto può risultare esteticamente poco gradevole.

È opportuno evitare di segnare la parte superiore delle piastrelle con matite o pennarelli e dedicare particolare attenzione ai prodotti lucidi, patinati o lappati che dovranno essere coperti durante i lavori di cantiere.

-Attendere 48/72 ore prima di sottoporre il pavimento al normale transito.

La posa senza fuga, soprattutto nei grandi formati è fortemente sconsigliata dai maggiori produttori di collante per i seguenti motivi:

Difficoltà di assorbimento di eventuali movimenti strutturali in assenza di elementi comprimibili

Diverso comportamento dilatometrico fra piastrelle e massetto, in presenza di elevate escursioni termiche

Difficoltà di realizzazione di una duratura ed efficace stuccatura

Abk sconsiglia assolutamente pose senza fuga, per le quali si declina ogni responsabilità.

Durante le operazioni di posa, nel caso venga scelto uno schema sfalsato, evitare di far coincidere i vertici di una piastrella con la metà delle altre a fianco.

Soltanto i prodotti AUTO-LEVELING si prestano ad essere posati seguendo liberamente ogni schema di posa.

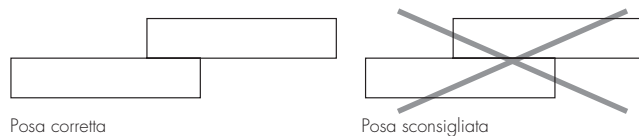

## STUCCATURA

1) Qualora non si utilizzasse la boiacca composta da cemento e sabbia, si consiglia di utilizzare colori di stucco su tono (possibilmente non utilizzare su materiali di colore chiaro stucchi di colore scuro, tipo nero, blu, rosso) e di verificare la compatibilità dei riempitivi per fughe con il prodotto ceramico.

2) Riempire le fughe con gli stucchi solo quando il pavimento è calpestabile, togliendo preventivamente dalle fughe ogni tipo di residuo.

3) Eseguire la stuccatura a "regola d'arte", seguendo le indicazioni del progettista, del responsabile di cantiere e del capitolato di posa.

4) Stuccare piccole superfici per volta (4/5 mq) e asportare le quantità eccedenti con spugne o stracci umidi (di sola acqua pulita).

5) Stucchi cementizi non additivati: seguire attentamente le indicazioni dei fabbricanti, a fine giornata pulire i residui di posa con spugna appena bagnata.

6) Stucchi epossidici o additivati (con lattici, ecc.): seguire attentamente le indicazioni dei fabbricanti, perché il loro rapido indurimento può richiedere pulizie molto laboriose, specialmente se la superficie delle piastrelle è antiscivolo, ruvida o strutturata.

## GENERAL WARNINGS

Regardless of the chosen product type or size, an on-site inspection should be carried out prior to installation to assess the conditions of the substrates. Perfect substrate conditions are essential for a successful installation. Substrates must be:

- dry and properly cured
- flat and free of cracks
- clean and free of dust, debris or lumps of cement
- compact and strong

The success of a floor or wall tile installation is the result of a combination of multiple factors; to achieve the best possible aesthetic effect in installation, remember that ABK Group products come in a variable number of graphic patterns packed in boxes in a completely random sequence.

## INSTALLATION OF RECTIFIED-EDGED TILES

For optimal results, ABK recommends allowing a joint of at least 1 or 2 mm when laying same-sized tiles and 2 or 3 mm for different-sized tiles laid using the modular systems described in the catalogues.

## INSTALLATION OF NON-RECTIFIED TILES

The high degree of vitrification of ABK tiles means dimensional tolerances are low. Therefore, when laying tiles with natural press-formed edges, at least a 3mm joint should be allowed between each tile.

## PRELIMINARY OPERATIONS

It is advisable to follow some recommendations before proceeding with the installation of the selected tiling material, which should be carried out in compliance with the technical requirements, style and intended application;

-Place some tiles (at least 3 m<sup>2</sup>) over the flooring surface to check the final effect, making sure you have the right tile size, shade, and quality class.

-In the case of products whose graphics tend to differ considerably from one tile to the next, it is advisable to take the tiles from different boxes and mix them. The graphic and colour variations of the tiles are an important feature which can be enhanced by a skilled tile layer. Overlooking such features, on the contrary, may lead to poor aesthetic results.

-Avoid marking the front of the tiles with pencils or markers. Be particularly careful with glossy, matt or lapped tiles, which should be kept covered during building work.

-Wait 48/72 hours before walking over the newly laid tiles.

Jointless tile installation, particularly in the case of large-size tiles, is strongly advised against by most adhesive manufacturers for the following reasons:

Any structural adjustments may not be absorbed due to the lack of compressible material.

Wide temperature ranges may cause expansion effects between the tile and screed.

Effective, durable grout joints may be difficult to achieve.

ABK strongly advises against jointless tile installation and cannot be held liable for any damage deriving therefrom.

When laying tiles in a staggered pattern, make sure there are no tiles positioned with the corner coinciding with the centre of the adjacent tiles.

Only AUTO-LEVELING products are suitable for all installation patterns.

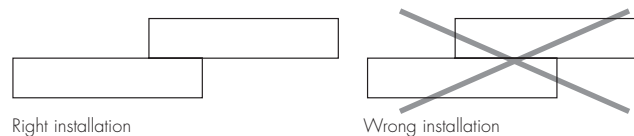

## GROUTING

1) Should a grout made of cement and sand not be used, it is recommended to use shade-on-shade grouts (do not use dark grouts, such as black, blue or red, on bright materials) and to verify the compatibility of the grouts with the ceramic tile.

2) Fill the grout lines with the grout only when the floor has sufficiently set to be ready to tread on, removing any residue from the grout lines.

3) Carry out a state-of-the-art grouting following the layer and technician's instructions and the technical specifications.

4) Grout small areas of the surface at a time (4m<sup>2</sup> to 5m<sup>2</sup>) and remove excess grout with a sponge or a wet cloth (with clean water).

5) Non-added cement grouts: follow the manufacturer's instructions carefully and at the end of the working day clean the surface with a slightly damp sponge.

6) Epoxy grouts or added grouts (with latex, etc): follow the manufacturer's instructions to the letter as rapid hardening can lead to difficult cleaning operations, especially in case of anti-slip, rough or textured tiles.



## LAVAGGIO DOPO LA POSA

Il lavaggio dopo la posa è una fase di fondamentale importanza per tutti gli interventi successivi e per la manutenzione.

La pulizia di fine cantiere fatta con prodotti a base acida tamponati, quali ad esempio Deterdek di Fila, Keranet di Mapei, Delta Plus di Kerakoll o Cement Remover di Faber, va eseguita una sola volta e presenta l'ulteriore vantaggio di conferire uniformità cromatica alla superficie.

Con il lavaggio acido dopo la posa si eliminano i residui di posa e il normale sporco di cantiere come: malta, colla, pittura, sporco da cantiere di varia natura. E' bene sapere che oltre il 90% delle contestazioni in cantiere è dovuto ad un cattivo, o addirittura inesistente, lavaggio con detergente acido dopo posa. Per evitare che un prodotto a base acida usato per la prima pulizia vada ad intaccare il riempimento a base cementizia delle fughe, è necessario, prima dell'operazione di pulizia, bagnare il pavimento affinché le fughe vengano impregnate e pertanto protette dall'azione corrosiva dell'acido stesso.

È opportuno:

- Togliere con appositi detergenti a base alcalina sostanze grasse o simili
- Procedere al lavaggio dopo la posa
- Risciacquare abbondantemente il pavimento, raccogliendo l'acqua residua.
- La pulizia si esegue dopo 4-5 giorni dalla stuccatura (lo stucco deve indurire) e non oltre i 10 giorni, oltre questi tempi la pulizia può diventare molto più laboriosa; attenersi scrupolosamente ai consigli riportati dal produttore di detergenti.

Fare sempre test preventivi (su una piastrella non posata), in particolare per prodotti lappati o levigati.

## POSA E PULIZIA DI DECORI CON MATERIALI NATURALI

### FASCIA PAPIER 2,5x30 cm

Componente legno: essenza di legno naturale lavorato artigianalmente a singolo pezzo e verniciato in modo da renderlo praticamente inassorbente. Componente supporto: il legno è supportato da WPC in lastre. Un materiale perfettamente stabile, ignifugo, inattaccabile da muffe e funghi e resistente a tutti gli acidi di uso domestico. Posa in opera e stuccatura: si possono usare le normali colle ceramiche da mosaico, utilizzando la tecnica della doppia spalmatura. Per la stuccatura usare esclusivamente stucchi epossidici, avendo cura di rimuovere l'eccedenza prima della completa essiccazione. Manutenzione e pulizia: si possono utilizzare i normali prodotti per il legno reperibili sul mercato, evitando assolutamente qualsiasi prodotto abrasivo.

### FASCIA ARDESIA BRONZO / ARDESIA GRIGIO 4x30 cm

Componente pietra naturale: lamina di Ardesia naturale proveniente dall'India, ottenuta attraverso l'uso di tecniche molto particolari ed esclusive. Componente supporto: la pietra è supportata dalla magnesite in lastre che è un inerte, perfettamente stabile, ignifugo, inattaccabile da muffe e funghi e resistente a tutti gli acidi di uso domestico. Posa in opera e stuccatura: si possono usare le normali colle ceramiche da mosaico, utilizzando la tecnica della doppia spalmatura. Per la stuccatura usare esclusivamente stucchi epossidici, avendo cura di rimuovere l'eccedenza prima della completa essiccazione. La manutenzione e la pulizia vanno fatte utilizzando i normali prodotti per il marmo / pietre naturali reperibili sul mercato, evitando i prodotti abrasivi.

### FASCIA ESSENZE MIX 5x30 cm

Componente legno: si tratta di tavole e travature in legno che vengono recuperate dalla demolizione di vecchi sottotetti, oppure da vecchie stalle, fienili, ricoveri attrezzi, ecc. E' materiale che proviene dalle zone prealpine del Trentino Alto Adige di età stimata non inferiore ad un centinaio di anni. Componente ceramica: ogni pezzo è stato lavorato manualmente sia come finitura del supporto che come smaltatura. Per queste ragioni ogni pezzo può variare di tono e/o di finitura. Componente supporto: il legno è stato supportato con la magnesite in lastre. Un materiale inerte, perfettamente stabile, ignifugo, inattaccabile da muffe e funghi e resistente a tutti gli acidi di uso domestico. Posa in opera: si possono usare le normali colle ceramiche da mosaico, reperibili sul mercato. Si raccomanda la tecnica della doppia spalmatura come in uso per la posa dei mosaici. Stuccatura: si consiglia di proteggere la componente legno con del nastro carta in modo da preservare la struttura del legno scavata dal tempo e di rimuovere il nastro solo a stuccatura perfettamente essiccata. Usare esclusivamente stucchi epossidici. Manutenzione e pulizia: il legno è verniciato ad acqua e rifinito con cere naturali. Successivamente è trattato con una soluzione idrorepellente incolore. Per la pulizia e la manutenzione sono utilizzabili i normali prodotti per il legno reperibili sul mercato adatti alla finitura sopra descritta. Per la ceramica sono consigliati i normali prodotti in commercio, evitando quelli abrasivi.

## CLEANING AFTER INSTALLATION

The cleaning after installation is of fundamental importance for all the subsequent steps and for a correct maintenance.

Post-installation cleaning using acid detergents with a padding action such as Fila Deterdek, Mapei Keranet, Kerakoll Delta Plus or Faber Cement Remover must be carried out only once and only if this would result in the added bonus of giving the surface a more uniform aspect.

Acid-cleaning will remove all residue associated with the installation and works in general, such as mortar, adhesive, paint and dirt. It is important to underline that 90% of complaints are due to a bad, or even inexistent cleaning after installation. In order to make sure that an acid detergent used for the cleaning does not compromise the filling of grout lines, it is necessary, before proceeding with cleaning, to wet the floors so that the grout lines are impregnated and protected from the corrosive action of the acid.

It is recommended to follow these steps:

First, remove any grease or similar substance from the floor using alkaline detergents

Proceed with the cleaning of the surface

Rinse the floors with an abundance of water

The cleaning must be carried out 4-5 days after grouting (the grout must season) and within a maximum of 10 days after grouting, as, beyond this period of time the cleaning can be difficult, carefully follow the manufacturer's instructions for the use of detergents.

It is always recommended to carry out a test on a sample tile (not installed), in particular in case of honed or polished products.

## LAYING AND CLEANING DECORS PRODUCED WITH NATURAL COMPONENTS

### FASCIA PAPIER 2,5x30 cm

Wood component: each natural wood piece is individually handcrafted and varnished to make it completely non-absorbent. Substrate: the wood is mounted on WPC panels. This material is perfectly stable, fireproof and resistant to mould and fungi as well as all household acids.

Installation and grouting: use normal ceramic mosaic adhesives and employ the back-buttering technique. Use exclusively epoxy grouts, being sure to remove any excess before it has dried completely.

Maintenance and cleaning: use normal commercially-available wood products. Do not use abrasive products.

### FASCIA ARDESIA BRONZO / ARDESIA GRIGIO 4x30 cm

Natural stone component: sheet of natural slate from India produced using exclusive techniques.

Substrate: slabs of magnesite, a perfectly stable material that is fireproof and resistant to mould and fungi as well as all household acids. Installation and grouting: use normal ceramic mosaic adhesives and employ the back-buttering technique. Use exclusively epoxy grouts, being sure to remove any excess before it has dried completely.

For maintenance and cleaning, use normal commercially-available products designed for marble/natural stone. Do not use abrasive products.

### FASCIA ESSENZE MIX 5x30 cm

Wood component: wooden planks and beams recovered from demolished attics or from old stables, barns, tool sheds, etc. This material originates from the foothills of the Alps in Italy's Trentino Alto Adige region and is estimated to be at least a hundred years old.

Ceramic component: each piece is hand finished and glazed and may consequently vary in terms of colour and/or finish.

Substrate: the wood is mounted on magnesite panels, a perfectly stable and fireproof material that is resistant to mould and fungi as well as all household acids.

Installation: use normal commercially-available ceramic mosaic adhesives. Use the back-buttering technique normally employed for installing mosaics.

Grouting: use paper tape to protect the wood component and preserve the wood's timeworn texture. Do not remove the tape until the grout has dried completely. Use only epoxy grouts.

Maintenance and cleaning: the wood is coated with water-based varnish and finished with natural wax. It is then treated with a colourless water-repellent solution. For cleaning and maintenance, use normal commercially-available wood products suited to the varnished and waxed finish. For the ceramic component, normal commercially-available products are recommended. Avoid using abrasive products.

## PULIZIA E MANUTENZIONE

### MANUTENZIONE ORDINARIA

Si consiglia l'utilizzo di un comune detergente neutro diluito in acqua calda. Evitare l'utilizzo di prodotti acidi, alcalini, ceranti e/o impregnanti.

Nella pulizia ordinaria occorre limitare l'uso di mezzi abrasivi (ad esempio: paglietta di metallo, spugnette di ferro o acciaio). Questa precauzione diventa un obbligo nel caso di piastrelle con superficie lucida, più esposte ad effetti visibili di scalfitture, graffi...

In caso di sporchi più intensi o di superfici particolarmente strutturate, usare un detergente a base alcalina risciacquando al termine del lavaggio.

Nella pratica quotidiana occorre considerare che certi tipi di sporco (polvere, sabbia) aumentano l'effetto abrasivo del traffico pedonale. Cercare quindi di prevenire la presenza di questa tipologia di sporco dall'esterno, predisponendo l'utilizzo di zerbino o stuoino all'ingresso.

### REMOZIONE DI PATINE LUCIDE

Nei normali detergenti in commercio sono a volte contenute cere o additivi lucidanti che, lavaggio dopo lavaggio, depositano sul pavimento patine lucide, causa di noiose alonature. Patine di questo tipo possono essere depositate anche da alcuni stucchi per le fughe. Semplici alimenti come Coca Cola, vino, acqua, etc., cadendo sul pavimento tolgono questa patina lucida e ripristinano l'aspetto originale più opaco delle piastrelle. In mezzo al pavimento più lucido, le zone senza cera appaiono come aloni opachi, in realtà sono le uniche parti pulite del pavimento.

In questi casi, dopo aver fatto un test preventivo, bisogna:

- Togliere la patina lucida da tutto il pavimento con un tipo di detergente a base alcalina.
- Utilizzare per le pulizie quotidiane, detergenti neutri che non contengono né cere né patine lucidanti.

### MANUTENZIONE STRAORDINARIA

Nel caso di tracce di sporco resistente alla pulizia ordinaria si raccomanda l'utilizzo di un detergente adeguato in funzione del tipo di sporco e comunque, prima dell'uso, fare sempre test preventivi su una piastrella non posata. Nella tabella "PRODOTTI PER LA PULIZIA E LA MANUTENZIONE" sono indicati i detergenti efficaci in funzione del tipo di macchia.

### PAVIMENTI E RIVESTIMENTI METALLIZZATI

Per la pulizia e manutenzione di piastrelle metallizzate si raccomanda di non usare assolutamente detergenti acidi o alcalini. Usare esclusivamente prodotti con PH neutro come ad esempio Fila Cleaner o Floor Cleaner di Faber. In ogni caso verificare sempre prima il prodotto su una porzione di materiale non posato ed evitare di lasciare il detergente sulle piastrelle per più di 10-15 min. Risciacquare sempre abbondantemente con acqua.

### TRATTAMENTO PRODOTTI LAPPATI E LEVIGATI

Lappatura e Levigatura sono lavorazioni che prevedono sempre l'asportazione di una parte superficiale dello smalto o del corpo stesso della piastrella. In tutti i pavimenti ceramici disponibili sul mercato, tale lavorazione, pur in presenza di materiali vetrosi o a bassissimo assorbimento, può comportare l'apertura di microporosità superficiali che a contatto con particolari tipi di sporco, possono risultare di difficile pulizia o presentare aloni difficilmente rimuovibili.

Dopo il lavaggio di post-posa Abk consiglia di procedere ad un trattamento antimacchia con prodotti certificati (marche raccomandate: Fila, Mapei, Kerakoll, Faber).

### RACCOMANDAZIONI

Ricordiamo di non usare mai detergenti a base di acido fluoridrico (HF) o dei suoi composti, compresi antiruggine o smacchiatori di tipo spray che spesso lo contengono. Il danno che si potrà provocare sarà irreparabile in quanto non esiste pavimento sul mercato resistente a tale acido.

### AVVERTENZE

Le caratteristiche di pulizia dei materiali variano in modo significativo in funzione delle diverse modalità di installazione, condizioni d'uso, tipologie di superfici e ambiente. In linea generale all'aumentare delle caratteristiche di antiscivolo delle piastrelle, aumentano le difficoltà di pulizia. L'operatore professionale incaricato dell'intervento di manutenzione e pulizia, dovrà sempre procedere ad una preliminare verifica empirica, possibilmente su una porzione di materiale non posato, per ogni singolo tipo di intervento.

In caso di condizioni d'uso particolarmente gravose, di errata installazione o di pulizie effettuate in modo inadeguato Abk declina ogni responsabilità in merito all'efficacia delle operazioni di pulizia e manutenzione. Resta inteso che Abk non potrà essere ritenuta responsabile per eventuali danni o difetti dovuti ad errata installazione, negligente pulizia e manutenzione o inadeguata scelta della tipologia dei materiali installati e degli adesivi utilizzati con riguardo alla destinazione.

Le indicazioni contenute in questo paragrafo sono puramente indicative. Per notizie più approfondite rimandiamo a documentazione specializzata disponibile su cataloghi e siti web delle principali ditte produttrici di prodotti specifici per la pulizia dei pavimenti.

## CLEANING AND MAINTENANCE

### DAILY MAINTENANCE

It is recommended to clean the floor using a neutral detergent diluted in hot water. Avoid the use of acid, alkaline, waxing and/or impregnating products.

During ordinary cleaning procedures, it is recommended to limit the use of abrasive means such as scouring pads, iron and/or steel sponges. Taking this precaution is a must on glossy tiles, as they are more liable to scratching.

In case of intense dirt or textured surfaces, use an alkaline detergent, rinsing the floor with an abundance of water.

It is important to underline that certain types of dirt like dust or sand, increase the abrasive effect of foot traffic on the surface. The use of a door mat at the entrance can help prevent this.

### REMOVAL OF FILMS ON THE FLOOR

The standard detergents available on the market sometimes contain waxes or polishing additives that, cleaning after cleaning, create a film on the floor and cause rims. This type of film can also develop when using certain types of grouts. Everyday stains on the floor, such as cola, wine, water, etc. remove this film and reveal the original, more opaque aspect of the tiled surface. On a glossy floor, these areas with no wax appear as rims but, in actual fact, they are the only clean areas of the floor itself.

In such cases, after having carried out a test, it is necessary to:

Remove the film from the floor using an alkaline detergent.

Use neutral detergents, which do not contain wax or polishing additives for everyday cleaning.

### EXTRAORDINARY MAINTENANCE

In case of stains that are resistant to standard cleaning operations, it is recommended to use a specific detergent depending on the type of dirt and, every single time before using such detergent, to carry out a test on a non-installed sample tile. The chart "REMOVE STAINS" indicates the recommended detergents that are effective for certain specific stains.

### METALLISED FLOOR AND WALL COVERINGS

For the cleaning and maintenance of metallised tiles, it is recommended not to use acid or alkaline detergents. Use products with neutral PH such as Fila Cleaner or Faber Floor Cleaner. Every single time, test the product on a sample tile that has not been installed and do not leave the detergent on the tiles for more than 10-15 minutes. Always rinse the surface with an abundance of water.

### TREATMENT OF HONED AND POLISHED TILES

Honing and polishing are manufacturing processes that always remove a superficial part of the glaze or of the body of the tile itself. All honed and/or polished ceramic tiles available on the market have a micro-porous structure that, even when using low absorption vitreous materials, are vulnerable to attack from certain types of dirt that can attack the micro-porous structure and make cleaning operations very difficult.

After post-installation cleaning using an acid detergent, Ceramiche ABK recommends an anti-stain treatment using specific products (suggested products: Fila, Mapei, Kerakoll, Faber).

### RECOMMENDATIONS

Never use hydrofluoric acid-based detergents or its derivatives, such as rust-preventing products or spray stain-removers that often contain hydrofluoric acid. The use of hydrofluoric acid will irreparably damage the surface, as no ceramic tile floor available on the market is resistant to this acid.

### WARNING

The cleaning features of materials considerably vary depending on the installation pattern, the conditions of use and the type of surface. As a general rule, as the anti-slip value of ceramic tile increases, the cleaning operations become more difficult. The professional technician in charge of the cleaning and maintenance must always carry out a preliminary test on a sample tile that has not been installed before proceeding with any cleaning operation.

In case of special conditions of use, incorrect installation or inadequate cleaning, Ceramiche ABK will not be responsible for the effectiveness of cleaning and maintenance procedures. It is agreed that ABK will not be responsible for any damage or defects that are due to incorrect installation, cleaning and maintenance or due a wrong choice of materials and adhesives.

The above-stated instructions are merely indicative. For in-depth information, please consult the specific documents that are available on the catalogues and web-site of the manufacturers of detergents for ceramic floors.

**PRODOTTI PER LA PULIZIA E LA MANUTENZIONE**  
**CLEANING AND MAINTENANCE PRODUCTS**

TIPO DI MACCHIA TYPE OF STAIN		DETERGENTE CONSIGLIATO DETERGENT	
MACCHIE INORGANICHE INORGANIC STAINS	CALCARE LIME	ACIDA ACID	DETERDEK (FILA) - CEMENT REMOVER (FABER)
	CEMENTO - SALNITRO CEMENT - SALTPETRE		DETERDEK (FILA) - CEMENT REMOVER (FABER)
	DEPOSITI CALCAREI DEPOSITS OF LIME		VIAKAL
	RUGGINE RUST		DETERDEK (FILA) - CEMENT REMOVER (FABER)
	SEGNI METALLICI METALLIC MARKS		DETERDEK (FILA)
MACCHIE ORGANICHE ORGANIC STAINS	BIRRA BEER	ALCALINA ALKALINE	PS/87 (FILA) - WAX REMOVER (FABER)
	CAFFÈ COFFEE		PS/87 (FILA) - SR/95 (FILA) - WAX REMOVER (FABER)
	COLA COCA COLA		PS/87 (FILA) - SR/95 (FILA) - WAX REMOVER (FABER)
	MACCHIE VEGETALI VEGETABLE FAT		WAX REMOVER (FABER)
	OLIO E GRASSO OIL AND GREASE		PS/87 (FILA) - WAX REMOVER (FABER)
	PNEUMATICI TIRES		PS/87 (FILA) - POLISHING CREAM (FABER)
	TINTURA PER CAPELLI HAIR DYE		PS/87 (FILA) - SR/95 (FILA) - COLOURED STAIN REMOVER(FABER)
	VINO WINE		PS/87 (FILA) - SR/95 (FILA) - OXIDANT (FABER)
MACCHIE SINTETICHE SYNTHETIC STAINS	VERNICE PAINT	SOLVENTE DISSOLVENT	PS/87 (FILA) - NOPAINTSTAR (FILA)
	BITUME BITUMEN		FILASOLV (FILA) - WAX REMOVER (FABER)
	CERA DI CANDELA CANDLE WAX		FILASOLV (FILA) - WAX REMOVER (FABER)
	INCHIOSTRO INK		PS/87 (FILA) - SR/95 (FILA) - COLOURED STAIN REMOVER(FABER)
	PENNARELLO FELT-TIP PEN		PS/87 (FILA) - SR/95 (FILA) - COLOURED STAIN REMOVER(FABER)
	RESIDUI DI SCOTCH REST OF STICKY TAPE		FILASOLV (FILA) - PS/87 (FILA) - SOLVENT STRIPPER (FABER)
ALONATURE RESIDUE RESIDUAL MARKS	SPORCO DELLE FUGHE TILE JOINT STAINS	DETERGENTE DETERGENT	FUGANET (FILA)
	ALONATURE VENTOSE STAINS FROM SUCTION CUPS		DETERDEK (FILA) + ALKALINE CLEANER (FABER)
	CERA PROTETTIVA PROTECTIVE WAX		DETERDEK (FILA)+FILASOLV (FILA) +SOLVENT STRIPPER (FABER) +WAX REMOVER (FABER)

Attenzione: i prodotti a base acida possono corrodere marmo, granito, pietre naturali e metalli, pertanto evitarne l'uso nel caso di decori o inserti realizzati con questi materiali.  
 Important: Acid products may corrode marble, granite, natural stone and metal. Avoid using in the presence of decoration or inserts in these materials.

PER L'USO ATTENERSI SCRUPolosAMENTE ALLE INDICAZIONI RIPORTATE SULL'ETICHETTA.  
 FOR THE CORRECT USE PLEASE FOLLOW THE INSTRUCTION MENTIONED ON THE LABEL.



## CARATTERISTICHE TECNICHE

### LE NORME ISO

QUESTE NORME, ELABORATE DALL'ISO TC 189, SOSTITUISCONO IN ITALIA, E NEI PAESI CHE LE HANNO RICONOSCIUTE, QUELLE PRECEDENTEMENTE ESISTENTI (EN).

Definiscono i criteri di campionamento, controllo ed accettazione di tutte le piastrelle di ceramica: pressate, estruse o realizzate mediante altri processi, smaltate e non smaltate e di qualunque formato. Le norme ISO della serie 10545 definiscono il procedimento per campionare le piastrelle che dovranno essere sottoposte a prova (ISO 10545.1) ed i metodi di prova per verificare la qualità delle piastrelle, mediante la determinazione delle caratteristiche d'aspetto, dimensionali e delle proprietà chimiche e fisiche (ISO 10545.2 - 16).

Gli standard relativi al prodotto, in cui sono contenuti i limiti di accettabilità che definiscono i materiali di prima scelta, sono invece stati raccolti nelle norme della serie ISO 13006. Sono stati definiti 11 allegati che identificano i vari prodotti ceramici, suddividendoli in relazione al grado di assorbimento d'acqua ed alla formatura.

Con la lettera A sono ancora definite le piastrelle estruse. Con la lettera B quelle pressate a secco le quali, in funzione dell'assorbimento d'acqua, sono così ulteriormente divise.

Nell'approvarle in Europa il CEN le ha raggruppate in un'unica norma, la EN 14411:2012, che con i diversi allegati copre tutti i capitoli ed i contenuti delle norme ISO.

## TECHNICAL CHARACTERISTICS

### THE ISO STANDARDS

THESE STANDARDS, DRAWN UP BY THE ISO TC189, REPLACE THE PREVIOUS (EN) STANDARDS IN ITALY AND IN THE OTHER COUNTRIES THEY ARE RECOGNIZED.

They outline the sampling, checking and acceptance criteria to apply to all ceramic tiles, whether pressed, extruded or produced with other processes, glazed or unglazed and whatever the format. The ISO 10545 series standards establish the procedure for sampling tiles to undergo testing (ISO 10545.1) and the testing methods to check the tile quality, by determining the aspects of appearance, size and chemical and physical properties (ISO 10545.2 - 16).

The standards relating to the product, on the other hand (which include the limits of acceptability used to determine the first class material), are grouped together in the ISO 13006 series standards. 11 annexes have been established which identify the various ceramic products, subdividing them according to water absorption and moulding.

The letter A is still used to identify the extruded tiles and the letter B is used to identify the dry pressed tiles. These letters are then divided up further according to their water absorption rate as follows:

When approving them in Europe the CEN grouped them into a single standard, the EN 14411:2012, which covers all the sections and contents of the ISO standards in its annexes.

ALLEGATO ANNEX	GRUPPO GROUP	ASSORBIMENTO D'ACQUA (E) WATER ABSORPTION (E)
G	Bla	$E \leq 0,5\%$
H	B1b	$0,5\% < E \leq 3\%$
I	B1a	$3\% < E \leq 6\%$
J	B1b	$6\% < E \leq 10\%$
K	B11	$E > 10\%$

**GRES PORCELLANATO / PORCELAIN STONEWARE**

 CLASSIFICAZIONE SECONDO NORME UNI EN 14411 (ISO 13006) ALLEGATO G-Gruppo Bla  
 CLASSIFICATION IN ACCORDANCE WITH UNI EN 14411 (ISO 13006) ANNEX G-Group Bla

PROPRIETÀ FISICO-CHIMICHE PHYSICAL-CHEMICAL PROPERTIES	NORMA NORM	VALORE PRESCRITTO DALLE NORME VALUE PRESCRIBED FROM THE NORMS	VALORE ABK VALUE ABK
LUNGHEZZA E LARGHEZZA DIMENSIONE MEDIA DI OGNI PIASTRELLA LENGTH AND WIDTH OF THE AVERAGE-SIZES TILE	UNI EN ISO 10545/2	± 0,5%	CONFORME ACCORDING
SPESSORE THICKNESS	UNI EN ISO 10545/2	± 5%	CONFORME ACCORDING
RETTILINEARITÀ SPIGOLI WARPAGES OF EDGES	UNI EN ISO 10545/2	± 0,5%	CONFORME ACCORDING
ORTOGONALITÀ WEDGING	UNI EN ISO 10545/2	± 0,6%	CONFORME ACCORDING
PLANARITÀ FLATNESS	UNI EN ISO 10545/2	± 0,5%	CONFORME ACCORDING
ASSORBIMENTO D'ACQUA WATER ABSORPTION	UNI EN ISO 10545/3	$E \leq 0,5\%$	CONFORME ACCORDING
RESISTENZA ALLA FLESSIONE BENDING STRENGTH	UNI EN ISO 10545/4	$\geq 35 \text{ N/mm}^2$	CONFORME ACCORDING
FORZA DI ROTTURA BREAKING STRENGTH	UNI EN ISO 10545/4	$\geq 1300 \text{ N}$	CONFORME ACCORDING
RESISTENZA ALL'ABRASIONE SUPERFICIALE PER PIASTRELLE SMALTATE ABRASION RESISTANCE FOR GLAZED TILES	UNI EN ISO 10545/7	IN FUNZIONE DELLA DESTINAZIONE D'USO ACCORDING TO THE DESTINATION OF FINAL USE	VEDI COLLEZIONE SEE COLLECTION
RESISTENZA AGLI SBALZI TERMICI THERMAL SHOCK RESISTANCE	UNI EN ISO 10545/9	RICHIESTA REQUIRED	RESISTE RESISTS
RESISTENZA AL GELO FROST RESISTANCE	UNI EN ISO 10545/12	RICHIESTA REQUIRED	INGELIVO FROST PROOF
RESISTENZA ALL'ATTACCO CHIMICO CHEMICAL RESISTANCE	UNI EN ISO 10545/13	-	RESISTE RESISTS
RESISTENZA ALLE MACCHIE RESISTANCE TO STAINING	UNI EN ISO 10545/14	GL $\geq$ MINIMO CLASSE 3	RESISTE RESISTS
RESISTENZA ALLO SCIVOLAMENTO SLIP RESISTANCE	B.C.R.A. C.A.	$\mu$ 0,19 SCIVOLOSITÀ PERICOLOSA - DANGEROUSLY SLIPPERY 0,20 < $\mu$ < 0,39 SCIVOLOSITÀ ECCESSIVA - EXCESSIVELY SLIPPERY 0,40 < $\mu$ < 0,74 ATTRITO SODDISFACENTE - SATISFACTORY GRIP $\mu$ 0,75 ATTRITO ECCELLENTE - EXCELLENT GRIP	VEDI COLLEZIONE SEE COLLECTION
	B.C.R.A. G.B.		
	ASTM C 1028 (S.C.O.F.)	SLIP RESISTANT (> 0,60)	VEDI COLLEZIONE SEE COLLECTION
	DIN 51130	IN FUNZIONE DELL'AMBIENTE O DELLA ZONA DI LAVORO BASING ON THE ENVIRONMENT OR THE WORKING AREA	VEDI COLLEZIONE SEE COLLECTION
	DIN 51097	-	VEDI COLLEZIONE SEE COLLECTION
	ANSI A 137-1:2012	> 0,42	VEDI COLLEZIONE SEE COLLECTION
	AS/NZS 4586 :2013	SRV : 35 - 44 SRV : 45 - 54	VEDI COLLEZIONE SEE COLLECTION

VARIAZIONE CROMATICA SHADE VARIATION	VEDI COLLEZIONE SEE COLLECTION	 aspetto uniforme uniform appearance V1	 lieve variazione slight variation V2	 moderata variazione moderate variation V3	 forte variazione substantial variation V4
---	-----------------------------------	--	--	---	---

## CARATTERISTICHE TECNICHE TECHNICAL CHARACTERISTICS

W&P

CLASSIFICAZIONE SECONDO NORME UNI EN 14411 (ISO 13006) Allegato G - Gruppo B11b  
CLASSIFICATION IN ACCORDANCE WITH UNI EN 14411 (ISO 13006) Annex G - Group B11b

PROPRIETÀ FISICO - CHIMICHE PHYSICAL - CHEMICAL PROPERTIES	NORMA NORM	GRES PORCELLANATO PORCELAIN TILES VALORE PRESCRITTO DALLE NORME VALUE PRESCRIBED FROM THE NORMS CLASSIFICAZIONE SECONDO NORME EN 14411 (ISO 13006) - ALLEGATO G - Gruppo B11b CLASSIFICATION IN ACCORDANCE WITH EN 14411 (ISO 13006) - ANNEX G - Group B11b	PASTA BIANCA DA RIVESTIMENTO W&P W&P WHITE BODY WALL TILES VALORE ABK ABK VALUE CLASSIFICAZIONE SECONDO NORME EN 14411 (ISO 13006) - Gruppo B11b CLASSIFICATION IN ACCORDANCE WITH EN 14411 (ISO 13006) - Group B11b	PASTA BIANCA DA RIVESTIMENTO WHITE BODY WALL TILES VALORE PRESCRITTO DALLE NORME VALUE PRESCRIBED FROM THE NORMS CLASSIFICAZIONE SECONDO NORME EN 14411 (ISO 13006) - Gruppo B11b CLASSIFICATION IN ACCORDANCE WITH EN 14411 (ISO 13006) - Group B11b
LUNGHE E LARGH. DIMENSIONE MEDIA DI OGNI PIASTRELLA LENGTH AND WIDTH OF THE AVERAGE-SIZES TILES	UNI EN ISO 10545/2	± 0,5%	solo Rettificato only Rectified	l ≤ 12 cm: 0,5% l > 12 cm: 0,3%
SPESSORE THICKNESS	UNI EN ISO 10545/2	± 5,0%	± 5,0%	± 10%
RETTILINEARITÀ SPIGOLI WARPAGES OF EDGES	UNI EN ISO 10545/2	± 0,5%	± 0,3%	± 0,3%
ORTOGONALITÀ WEDGING	UNI EN ISO 10545/2	± 0,6%	± 0,5%	± 0,5%
PLANARITÀ FLATNESS	UNI EN ISO 10545/2	+ 0,5%	± 0,3%	+ 0,5% - 0,3%
ASSORBIMENTO D'ACQUA WATER ABSORPTION	UNI EN ISO 10545/3	E ≤ 0,5%	E ≤ 6%	> 10%
RESISTENZA ALLA FLESSIONE BENDING STRENGTH	UNI EN ISO 10545/4	≥ 35 N/mm <sup>2</sup>	≥ 30 N/mm <sup>2</sup>	per spessore ≥ 7,5 mm > 15 N/mm <sup>2</sup> per spessore < 7,5 mm > 12 N/mm <sup>2</sup>
FORZA DI ROTTURA BREAKING STRENGTH	UNI EN ISO 10545/4	per spessore ≥ 7,5 mm ≥ 1300 N per spessore < 7,5 mm ≥ 700 N	> 700 N	-
RESISTENZA AGLI SBALZI TERMICI THERMAL SHOCK RESISTANCE	UNI EN ISO 10545/9	RICHIESTA REQUIRED	RICHIESTA REQUIRED	RICHIESTA REQUIRED
RESISTENZA AL GELO FROST RESISTANCE	UNI EN ISO 10545/12	RICHIESTA REQUIRED	NON RICHIESTA NOT REQUIRED	NON RICHIESTA NOT REQUIRED
RESISTENZA ALLE MACCHIE RESISTANCE TO STAINING	UNI EN ISO 10545/14	GL ≥ MINIMO CLASSE 3	GL ≥ MINIMO CLASSE 3	CLASSE 3 MINIMO CLASS 3 MINIMUM
DILATAZIONE DELL'UMIDITÀ MOISTURE EXPANSION	UNI EN ISO 10545-10	≤ 0,1 (mm/m)	≤ 0,1 (mm/m)	≤ 0,3 (mm/m)



**BICOTTURA / DOUBLE-FIRED WALL TILES**CLASSIFICAZIONE SECONDO NORME UNI EN 14411 (ISO 13006) Gruppo BIII  
CLASSIFICATION IN ACCORDANCE WITH UNI EN 14411 (ISO 13006) Group BIII

PROPRIETÀ FISICO-CHIMICHE PHYSICAL-CHEMICAL PROPERTIES	NORMA NORM	VALORE PRESCRITTO DALLE NORME VALUE PRESCRIBED FROM THE NORMS	VALORE ABK VALUE ABK
LUNGHEZZA E LARGHEZZA DIMENSIONE MEDIA DI OGNI PIASTRELLA LENGTH AND WIDTH OF THE AVERAGE-SIZES TILE	UNI EN ISO 10545/2	$l \leq 12 \text{ cm}: \pm 0,5\%$	CONFORME ACCORDING
		$l > 12 \text{ cm}: \pm 0,3\%$	
SPESSORE THICKNESS	UNI EN ISO 10545/2	$\pm 10\%$	CONFORME ACCORDING
RETTILINEARITÀ SPIGOLI WARPAGES OF EDGES	UNI EN ISO 10545/2	$\pm 0,3\%$	CONFORME ACCORDING
ORTOGONALITÀ WEDGING	UNI EN ISO 10545/2	$\pm 0,5\%$	CONFORME ACCORDING
PLANARITÀ FLATNESS	UNI EN ISO 10545/2	+ 0,5% - 0,3%	CONFORME ACCORDING
ASSORBIMENTO D'ACQUA WATER ABSORPTION	UNI EN ISO 10545/3	> 10%	CONFORME ACCORDING
RESISTENZA ALLA FLESSIONE BENDING STRENGTH	UNI EN ISO 10545/4	per spessore $\geq 7,5 \text{ mm}$ >15 N/mm <sup>2</sup>	CONFORME ACCORDING
		per spessore < 7,5 mm >12 N/mm <sup>2</sup>	
RESISTENZA AGLI SBALZI TERMICI THERMAL SHOCK RESISTANCE	UNI EN ISO 10545/9	RICHIESTA REQUIRED	RESISTE RESISTS
RESISTENZA ALLE MACCHIE RESISTANCE TO STAINING	UNI EN ISO 10545/14	CLASSE 3 MINIMO CLASS 3 MINIMUM	CLASSE 4 MIN CLASS 4 MIN

**MONOCOTTURA DA RIVESTIMENTO / SINGLE-FIRED WALL TILES**CLASSIFICAZIONE SECONDO NORME UNI EN 14411 (ISO 13006) Gruppo BIIb  
CLASSIFICATION IN ACCORDANCE WITH UNI EN 14411 (ISO 13006) Group BIIb

PROPRIETÀ FISICO-CHIMICHE PHYSICAL-CHEMICAL PROPERTIES	NORMA NORM	VALORE PRESCRITTO DALLE NORME VALUE PRESCRIBED FROM THE NORMS	VALORE ABK VALUE ABK
LUNGHEZZA E LARGHEZZA DIMENSIONE MEDIA DI OGNI PIASTRELLA LENGTH AND WIDTH OF THE AVERAGE-SIZES TILE	UNI EN ISO 10545/2	$\pm 0,5\%$	CONFORME ACCORDING
SPESSORE THICKNESS	UNI EN ISO 10545/2	formato 10x10 $\pm 10\%$	CONFORME ACCORDING
RETTILINEARITÀ SPIGOLI WARPAGES OF EDGES	UNI EN ISO 10545/2	$\pm 0,5\%$	CONFORME ACCORDING
ORTOGONALITÀ WEDGING	UNI EN ISO 10545/2	$\pm 0,6\%$	CONFORME ACCORDING
PLANARITÀ FLATNESS	UNI EN ISO 10545/2	+ 0,5%	CONFORME ACCORDING
ASSORBIMENTO D'ACQUA WATER ABSORPTION	UNI EN ISO 10545/3	$6\% < E \leq 10\%$	CONFORME ACCORDING
RESISTENZA ALLA FLESSIONE BENDING STRENGTH	UNI EN ISO 10545/4	>18 N/mm <sup>2</sup>	CONFORME ACCORDING
RESISTENZA AGLI SBALZI TERMICI THERMAL SHOCK RESISTANCE	UNI EN ISO 10545/9	RICHIESTA REQUIRED	RESISTE RESISTS
CESSIONE DI PIOMBO Pb LEAD RELEASE	UNI EN ISO 10545/15	-	NPD*
CESSIONE DI CADMIO Cd CADMIUM RELEASE	UNI EN ISO 10545/15	-	NPD*

## ECOSOSTENIBILITÀ ECO-SUSTAINABILITY

Un ambiente ABK, oltre a distinguersi per il design, è sinonimo di qualità Made in Italy, ottenuta seguendo standard di sostenibilità sempre più evoluti.

L'80% dei materiali contenuti in questo catalogo viene prodotto con impasto ECO-BODY, contenente un 40% minimo di materie prime di qualità, recuperate da lavorazioni esterne; il valore di questa operazione è certificato da Bureau Veritas, che accredita i prodotti ECO-BODY anche all'interno del sistema internazionale LEED.

ABK promuove l'edilizia sostenibile, per questo è socio di Green Building Council Italia, l'associazione italiana dei leader che operano per trasformare il mercato dell'edilizia verso la sostenibilità ambientale. I soci GBC Italia promuovono la responsabilità ambientale, economica e sociale con contributi concreti all'innovazione, nel modo in cui gli edifici sono progettati, realizzati e utilizzati.

An ABK setting stands out as the standard-bearer of the Made in Italy design by pursuing continuously evolving sustainability standards.

Almost 80% of the materials illustrated in this catalogue is produced using the ceramic mixture ECO-BODY, which contains a minimum of 40% high-quality recycled material recovered from other industrial processes. The sustainability performance in these operations is officially certified by Bureau Veritas, that also validates ECO-BODY products to the standards of the LEED international rating system.

With a view to promoting sustainable building, ABK has become a member of Green Building Council Italia, the Italian association of top leaders with an aim to implementing more sustainable practices in the building industry. The members of GBC Italia promote environmental, economical and social responsibility, while contributing in a concrete way to innovation in terms of building design, realization and utilization.





60x120	 2	
INTERNO 9 RUST		
<b>I9R34300</b>	rett.	F 68,90
<b>I9L34300</b>	lapp rett.	F 81,90
CODICE ARTICOLO Article code	CATEGORIA PREZZO: F= prezzo espresso in Euro da calcolarsi al mq PZ= prezzo espresso in Euro da calcolarsi al pezzo	
NOME ARTICOLO Article name	PRICING CATEGORIES: F= price in euro per square meter PZ= price in euro per unit	
FORMATO Size	PEZZI PER SCATOLA Pieces per box	



### PIASTRELLE PER PAVIMENTI

Floor tiles | Carregales pour sol  
Bodenfliesen | Baldosas para pavimentos  
НАПОЛЬНАЯ ПЛИТКА



### PIASTRELLE PER RIVESTIMENTI

Wall Tiles | Faiences  
Wandfliesen | Baldosas para revestimientos  
ОБЛИЦОВОЧНАЯ ПЛИТКА



### SPESSORE

Thickness | Epaisseur  
Stärke | Espesor  
ТОЛЩИНА



### RESISTENZA AL GELO

Frost resistance | Résistance au gel  
Frostbeständigkeit | Resistencia a la helada  
МОРОЗОСТОЙКОСТЬ



### RESISTENZA ALLO SCIVOLAMENTO

Skid resistance | Résistance à la glissance  
Rutschfestigkeitskoeffizient  
Resistencia al deslizamiento  
КОЭФИЦИЕНТ СОПРОТИВЛЕНИЯ СКОЛЬЖЕНИЮ



### VARIAZIONE CROMATICA

Colour shade variation | Variation de nuances  
Farbabweichung | Variación cromática  
ИЗМЕНЕНИЕ ЦВЕТА



### V1 ASPETTO UNIFORME

V1 uniform appearance | V1 aspect uniforme  
V1 einheitliche optik | V1 aspecto uniforme  
V1 ОДНОРОДНЫЙ ВИД



### V2 LIEVE VARIAZIONE

V2 minimal variation | V2 légère variation  
V2 leichte farbabweichung | V2 variación ligera  
V2 ЛЕГКОЕ ИЗМЕНЕНИЕ



### V3 MODERATA VARIAZIONE

V3 moderate variation | V3 variation modérée  
V3 mässige farbabweichung | V3 variación moderada  
V3 УМЕРЕННОЕ ИЗМЕНЕНИЕ



### V4 FORTE VARIAZIONE

V4 substantial variation | V4 effet dénuancé très accentué  
V4 starke farbabweichung | V4 variación evidente  
V4 СИЛЬНОЕ ИЗМЕНЕНИЕ



### PRODOTTI COMPOSTI DA ECO-BODY, IMPASTO STANDARD LEED

Products made with ECO-BODY, standard LEED dough  
Produits composés d'Eco-body, Pâte standard LEED  
ECO-BODY PRODUKT, aus Standard LEED Scherbe  
Productos conformes a estándar leed  
Материал изготовлен из экологической смеси, соответствует стандарту LEED

## CONDIZIONI GENERALI DI VENDITA

---

1) **APPROVAZIONE** Gli ordini pervenuti sono per noi impegnativi solo dopo la nostra conferma scritta.

2) **CONSEGNA** La consegna del materiale s'intende avvenuta a carico effettuato presso i nostri magazzini. Tutti i rischi di trasporto, compresi ammanchi, rotture, deterioramenti e manomissioni sono a carico del Committente anche se il prezzo pattuito è franco di porto, FOB o C&F. Gli accordi con spedizionieri s'intendono sempre conclusi in nome e per conto del Committente che fin d'ora ratifica ed accetta l'operato.

3) **TERMINI DI CONSEGNA** I termini di consegna hanno carattere indicativo, eventuali ritardi nelle consegne, interruzioni, sospensioni totali o parziali delle forniture non daranno diritto ad indennizzi o risarcimento danni.

4) **CONTESTAZIONI** La garanzia della merce è limitata al solo, ed esclusivamente, materiale di prima scelta, con una tolleranza del 5% circa. Le differenze di tonalità non potranno essere denunciate come vizio del materiale. Eventuali reclami in merito alla qualità, tipo del materiale, dovranno pervenirci entro 8 giorni dalla data di consegna. Il compratore s'impegna a tenere a disposizione le partite contestate così da consentire il controllo dei difetti denunciati, in ogni caso la posa in opera ci esonera da qualsiasi responsabilità. Eventuali vizi o difetti di qualità della merce, ove siano denunciati nei termini di legge ed accertati o riconosciuti, danno diritto solamente alla sostituzione dei materiali difettosi, a condizione della preventiva restituzione delle merci contestate, e, su autorizzazione scritta dell'operazione di resa, restando tassativamente esclusi la risoluzione del contratto e qualsiasi risarcimento danni.

5) **DIMENSIONI E TONALITA'** I nostri materiali sono da classificarsi fra i prodotti cotti ad alta temperatura e come tali possono presentare differenze tra le dimensioni dichiarate e quelle effettivamente consegnate. Così si dica per le differenze di tono all'interno della medesima partita. Quanto sopra perciò non potrà essere oggetto di reclamo da parte del committente.

6) **IMBALLO E QUANTITA'** Il buono stato degli imballi e della loro confezione nonché della quantità consegnata resta accertato con l'accettazione della merce da parte del vettore. Questi, firmando la Bolla di Accompagnamento, si rende responsabile del buono stato del materiale e del quantitativo. Il compratore nel caso si verificano rotture ed ammanchi dovrà chiedere eventuali danni o risarcimenti al vettore.

7) **RESI** Per nessuna ragione l'acquirente potrà restituire il materiale senza nostra espressa preventiva autorizzazione scritta e tutte le spese sono a carico del Committente.

8) **ANNULLI** Non verranno accettati annullamenti di ordini se il materiale è già stato prodotto o se è già stata avviata la lavorazione e molto più se è già stata effettuata la spedizione. L'annullamento dell'ordine comporterà in ogni caso l'obbligo da parte del Committente di pagare l'intera fornitura. Nel caso che sia fattibile l'accettazione dell'annullamento il Cliente sarà tassativamente tenuto a rifondere tutte le spese sostenute dal produttore fino a quel momento.

9) **PREZZI** I prezzi riportati sui nostri listini non sono per noi impegnativi. Ci riserviamo il diritto di modificarli prima dell'accettazione dell'ordine.

10) **PAGAMENTI** I pagamenti devono essere effettuati solo presso la nostra sede. Il ritardo di 10 giorni di ogni pagamento dovuto, o la mancata copertura nel termine stesso di un titolo di credito, girato o ceduto o emesso dal committente, costituisce grado di insolvenza. In tal caso sarà nostra facoltà sospendere le forniture ed annullare ogni rapporto in corso; immediatamente esigere l'integrale pagamento di ogni rapporto in corso; esigere l'integrale pagamento di ogni nostro credito ed agire giudizialmente al riguardo, in via esecutiva o cautelare nonché per il risarcimento danni; in ogni caso, trascorsi 10 giorni da ogni pagamento dovuto, siamo autorizzati a emettere tratta a vista con spese senza preavviso. Inoltre decorreranno sul debito scaduto gli interessi moratori annui calcolati nella misura del tasso "prime rate" corrente maggiorato di 5 punti percentuali.

11) **UNITÀ MINIMA DI VENDITA** Non si effettuano vendite inferiori alla scatola.

12) **RISERVATO DOMINIO** Il materiale anche se spedito e regolarmente fatturato resta di nostra proprietà fino al pagamento totale della fornitura medesima anche in caso di passaggio o vendita terzi.

13) **FORO COMPETENTE** Per qualsiasi controversia sarà esclusivamente competente il foro di Modena.

## SERVIZI DI LOGISTICA

**ANNULLAMENTO ORDINI** per l'annullamento autorizzato di ordini di materiali già consegnati al nostro deposito e per resi autorizzati, verrà addebitato il 15% del valore imponibile, con fisso minimo di 20 €, per contributo spese di trasporto e rifelezione.

**ORDINI MINIMI** per ordinativi limitati che sono a "completamento" od "evasioni singole" il cui valore imponibile è inferiore a 100 €, verrà applicata una maggiorazione di 20 € netta fissa.

**SPALLETTIZZATO** per ordini di metratura inferiore al pallet completo, verrà applicata una maggiorazione fissa di 1,50 € al mq.

**CONSEGNE URGENTI** per preparazione di ordini entro le 24 ore, con un limite massimo di 2 articoli totali, verrà addebitata una maggiorazione di 30 € netta fissa.

## IMBALLAGGI

**ADDEBITO** gli imballaggi speciali delle collezioni Wide saranno addebitati al costo visibile nella sezione riepilogativa di pagina 379.

**RESO** gli stessi potranno essere resi e riaccreditati a condizione che vengano restituiti in buono stato.



# GENERAL SALES TERMS AND CONDITIONS

---

1) **APPROVAL** All orders that we receive are considered to be binding only after our written confirmation has been issued.

2) **DELIVERY** The materials are intended as delivered upon loading at our warehouses. All transport risks, including missing pieces, breakage, deterioration and tampering are the sole responsibility of the Client, even if the price agreed upon is carriage free, FOB, or C&F. Agreements with forwarding agents are intended as concluded in the name of and on behalf of the Client, who hereby confirms and accepts their terms and conditions.

3) **TERMS OF DELIVERY** The terms of delivery are indicative, eventual delays in the delivery, interruptions, or total or partial suspensions of the supply do not allow any right to indemnification or compensation for damages.

4) **DISPUTES** The guarantee of the goods is limited only and exclusively to first rate materials, with a tolerance of approximately 5%. The difference in shades of colour cannot be declared as a material defect. Eventual complaints regarding the quality or the type of material must be submitted within 8 days from the date of delivery. The purchaser agrees to make available the disputed lots in order that the declared defects may be controlled. In any case, the installation exonerates the manufacturer from any liability. Eventual manufacturing defects or quality defects in the goods, where declared according to law and ascertained or recognized, give right only to the replacement of the defective materials, provided that the goods have been returned previously and the written authorization of the return operation has been issued, the resolution of the contract as well as any compensation for damages is peremptorily waived and excluded.

5) **DIMENSIONS AND TONALITY** Our materials are classified as products fired at high temperatures and as such may present discrepancies between the dimensions declared and those actually delivered. The same applies for differences in colours within the same production lot. Therefore, the client may not present a dispute regarding abovementioned product characteristic.

6) **PACKAGING AND QUANTITY** The good condition of the packaging and cartons as well as the quantity delivered are verified upon acceptance of the goods by the forwarding agent. The forwarding agent declares himself responsible for the condition and quality of the goods upon signing the packing list. In case of missing pieces of breakage, the purchaser must ask for eventual damages or compensation from the forwarding agent.

7) **RETURNS** For no reason will purchaser be able to return the material without our express prior written authorization and all the costs of the return will be assumed by the Client.

8) **CANCELLATIONS** Order cancellations will not be accepted if the material has already been produced or if the production has already begun, and more so if the materials have already been shipped. In any case, the Client is obliged to pay the entire sum of the supply if the order is cancelled. If the acceptance of the cancellation is feasible, the Client will be peremptorily obliged to reimburse all the expenses sustained by the producer up to that moment.

9) **PRICES** The prices on our price list are not binding. We reserve the right to modify prices before accepting an order.

10) **PAYMENT** Payments must be made only in our main office. Delays of more than 10 days for each payment due or insufficient funds during the same term of a check, whether endorsed or transferred, or issued by the customer, constitutes bad debt. In this case, we reserve the right to suspend supply and annual all ongoing relations, immediately require total payment of all ongoing relations; require total payment of each credit and to make legal recourse, whether executive or precautionary, as well as request compensation for damages. In any case, after 10 days any payment due, we are authorized to issue an on-sight draft with expenses without notice. Furthermore, annual penalty interest will accumulate on the expired debt to be calculated according to the current "Prime rate" plus five (%) percentage points.

11) **MINIMUM PACKAGING REQUIREMENTS** Sales of less than one box will not be allowed.

12) **SELLER'S LIEN** The material, even if shipped and regularly invoiced, remains our property until payment in full of the invoice itself, even in case of passage or sale to third parties.

13) **PLACE OF JURISDICTION** For any eventual dispute, the only place of jurisdiction will be the Modena Tribunal.

## GENERAL NOTE

**CANCELLATION OF ORDERS** for the authorized cancellation of orders for materials already delivered to our warehouse and for authorized returns of the goods, 15% of the taxable value will be charged, with a minimum fixed contribution of € 20 towards transport and reselection costs.

**MINIMUM ORDERS** for limited orders to complete a previous order or for single deliveries, with a taxable value of less than € 100, there is a fixed net surcharge of € 20.

**ORDERS FOR LESS THAN 1 PALLET** for orders of less than 1 complete pallet, will be charged a fixed amount of 1,50 €/m<sup>2</sup>

**URGENT DELIVERIES** for orders to be prepared within 24 hours, with a maximum quantity of 2 articles, there is a fixed net surcharge of € 30.

## PACKAGING

### CHARGES

Special packaging for wide collections will be charged according to the schedule on page 379.

### RETURNS

The packaging may be returned in its original condition for credit against future orders.

## CONDITIONS GÉNÉRALES DE VENTE

---

**1) ACCEPTATION** Les commandes parvenues ne seront valables de manière définitive qu'après confirmation écrite de notre part.

**2) LIVRAISON** La livraison du matériel est à considérer effectuée au moment du chargement dans nos entrepôts. Tous les risques de transport, tels que les manques, les casses, détériorations ou endommagements sont à la charge de l'Acheteur, même lorsque le prix convenu est franco, FOB ou C&F. Les accords conclus avec les transporteurs sont à considérer toujours au nom et pour compte de l'Acheteur, qui confirme et accepte les conditions au préalable.

**3) DÉLAIS DE LIVRAISON** Les délais de livraison ont un caractère indicatif; les éventuels retards de livraisons, interruptions, suspensions totales ou partielles des fournitures ne donneront droit à aucun dédommagement ou remboursement et intérêts.

**4) CONTESTATIONS** La garantie de la marchandise se limite seulement et exclusivement au matériel de premier choix, avec une marge de tolérance de 5% environ. Les différences de nuances ne pourront être dénoncées comme vice du matériel. Les éventuelles réclamations relatives à la qualité, au type de matériel, devront nous parvenir dans les 8 jours à partir du jour de livraison. L'Acheteur s'engage à mettre à disposition les parties contestées de manière à permettre le contrôle des défauts déclarés, sachant que la pose nous libère quoiqu'il en soit de toute responsabilité. Les éventuels vices ou défauts de qualité de la marchandise, si déclarés en vertu des termes de loi et confirmés ou reconnus, ne donnent droit qu'à la substitution des matériaux défectueux, à condition que les marchandises contestées ne soient rendues préalablement et, sur autorisation écrite de l'opération de restitution, en renonçant et en excluant ainsi de manière formelle la résolution du contrat tout comme les éventuels dommages et intérêts.

**5) DIMENSIONS ET TONS** Nos matériels se classent parmi les produits cuits à haute températures et peuvent présenter en tant que tels des différences entre les dimensions déclarées et celles effectivement livrées.

C'est ainsi que sont considérées les différences de tons à l'intérieur d'un même lot. C'est pourquoi, en vertu des conditions présentées précédemment, ceci ne pourra faire l'objet d'aucune réclamation de la part de l'Acheteur.

**6) EMBALLAGE ET QUANTITES** Le bon état des emballages et de leur confection, ainsi que de la quantité livrée est confirmé après acceptation de la marchandise de la part du transporteur. Ce dernier, en signant le Bon de Livraison, se tient responsable du bon état du matériel et de la quantité. En cas de casses ou manques, l'acheteur devra demander des éventuels dommages et intérêts ou dédommagements au transporteur.

**7) RESTITUTIONS** En aucun cas l'Acheteur ne pourra rendre le matériel sans préalablement recevoir une autorisation écrite de notre part et tous les frais sont à la charge de l'Acheteur.

**8) ANNULLATIONS** Aucune annulation de commandes ne sera acceptée si le matériel a déjà été produit ou si la phase de production a déjà été commencée, ni même si la livraison a déjà été effectuée. L'annulation de la commande comportera dans tous les cas l'obligation de la part de l'Acheteur de payer la totalité de la marchandise. Au cas où l'acceptation de l'annulation est faisable, le Client sera formellement tenu à recouvrir tous les frais engendrés par le producteur jusqu'alors.

**9) PRIX** Les prix reportés sur nos catalogues ne sont pas définitifs. Nous nous réservons le droit de les modifier avant l'acceptation de la commande.

**10) PAIEMENTS** Les paiements ne doivent être effectués qu'auprès de notre siège. Le retard de plus de 10 jours de tout paiement dû ou la non couverture dans le même délai d'un titre de crédit, transféré ou cédé, ou bien émis par l'Acheteur, constitue un niveau d'insolvabilité. Dans ce cas, il est en notre pouvoir de suspendre les livraisons et annuler tout rapport en cours; d'exiger le paiement intégral et immédiat de nos crédits; d'exiger le paiement intégral de tout en notre faveur et d'agir judiciairement à cet égard, de manière exécutive ou préventive ainsi que pour les dommages et intérêts. Dans tous les cas, aussitôt qu'un paiement du dépasse le délai des 10 jours, nous sommes autorisés à émettre une traite à vue avec frais sans préavis. En outre, les intérêts moratoires annuels calculés en fonction du taux "premiers versements" courant majoré à 5 points pourcents, prendront effet sur le débit dépassé.

**11) MINIMUM UNITE DE VENTE** Aucune vente inférieure à la boîte ne peut être effectuée.

**12) DOMAINE RÉSERVÉ** Le matériel, même si livré et régulièrement facturé reste notre propriété jusqu'au paiement total de ladite marchandise, même en cas de passage ou vente à un tiers.

**13) TRIBUNAL COMPETENT** Le Tribunal de Modena sera compétent de manière exclusive en cas de litige.

## SERVICES LOGISTIQUES

**ANNULATION D'UNE COMMANDE** pour annuler une commande de matériaux déjà livrés à notre dépôt, et pour une restitution autorisée, une somme équivalente à 15 % de la valeur imposable vous sera débitée, avec un montant fixe minimum de 20 €, en tant que participation aux frais de transport et de resélection.

**COMMANDES MINIMUM** pour les commandes visant à "compléter" ou constituant des "expéditions individuelles" dont la valeur imposable est inférieure à 100 €, un supplément de 20 € net et fixe sera appliqué.

**CONTREMARQUE** pour toute commande inférieure à la palette, un montant fixe de 1,50 €/m<sup>2</sup> sera ajouté au prix d'achat

**LIVRAISONS URGENTES** pour la préparation de commandes à livrer dans les 24 heures, avec une limite maximum de 2 articles en tout, un supplément de 30 € net et fixe sera appliqué.

## EMBALLAGES

### COÛT

Les emballages spéciaux des collections Wide seront facturés au coût indiqué dans la section récapitulative de la page 379.

### RETOUR

Ils pourront être retournés et faire l'objet d'un remboursement à condition qu'ils soient en bon état.

# ALLGEMEINE VERKAUFSBEDINGUNGEN

---

1) **BESTÄTIGUNG** Eingegangene Bestellungen sind für uns nur verbindlich, wenn sie schriftlich durch uns bestätigt wurden.

2) **LIEFERUNG** Die Lieferung des Materials ist für uns mit dessen Beladung bei unserem Lager abgeschlossen. Alle durch den Transport bedingten Risiken, einschließlich Fehlmengen, Bruch, Beschädigung und sonstige Beeinträchtigungen gehen zu Lasten des Auftraggebers, auch wenn der vereinbarte Preis frachtfrei. FOB oder C&F ist. Die Vereinbarungen mit den Speditionsunternehmen werden im Namen und auf Rechnung des Auftraggebers getroffen, der die Entlastung bestätigt und erteilt.

3) **LIEFERFRISTEN** Die Lieferfristen sind ungefähre Angaben; im Falle einer Verzögerung, Unterbrechung bzw. teilweiser oder kompletter Aussetzung der Lieferungen besteht kein Recht auf Entschädigung oder Schadenersatz.

4) **BEANSTANDUNGEN** Die Garantie auf die Ware bezieht sich ausschließlich auf Material erster Wahl, bei einer Toleranz von ca. 5%. Unterschiede bei Farbtönen können nicht als Materialfehler geltend gemacht werden. Eventuelle Beanstandungen in Bezug auf die Qualität und Materialart müssen innerhalb von 8 Tagen ab dem Lieferdatum bei uns eingehen. Der Käufer verpflichtet sich, die beanstandeten Warenpartien für die Überprüfung der angezeigten Mängel zur Verfügung zu halten. Die Verlegung des Materials befreit uns in jedem Fall von jeglicher Haftung. Eventuelle Fehler oder Qualitätsmängel der Ware, sofern diese innerhalb der gesetzlich vorgeschriebenen Fristen gemeldet, überprüft und anerkannt wurden, beinhalten lediglich das Recht auf einen Umtausch der fehlerhaften Materialien, unter der Bedingung, dass die beanstandete Ware vorher, nach schriftlicher Genehmigung der Warenrückgabe, zurückgeschickt wurde und unter Verzicht und Ausschluss des Anspruchs auf eine Vertragsauflösung oder jegliche Art von Schadenersatz.

5) **ABMESSUNGEN UND FARBTÖNE** Unsere Materialien sind als Produkte klassifiziert, die bei hohen Temperaturen gebrannt werden, weshalb es sein kann, dass die tatsächlichen Abmessungen von den genannten Abmessungen abweichen. Das gleiche gilt für Farbunterschiede innerhalb desselben Warenpostens. Diese Umstände geben dem Auftraggeber kein Recht zu Beanstandungen.

6) **VERPACKUNG UND MENGE** Mit Annahme der Ware durch das Beförderungsunternehmen gelten der gute Zustand der Verpackungen sowie die übergebene Warenmenge als bestätigt. Das Transportunternehmen übernimmt mit Unterzeichnung des Versandscheins die Verantwortung für den guten Zustand und die Menge des Materials. Der Käufer muss sich im Fall von Brüchen oder Fehlware für eventuelle Schäden oder Entschädigungen an das Beförderungsunternehmen wenden.

7) **WARENRÜCKGABE** Der Käufer kann die Ware in keinem Fall ohne unsere ausdrückliche schriftliche Genehmigung zurückgeben; alle entstehenden Kosten werden vom Auftraggeber übernommen.

8) **STORNIERUNGEN** Auftragstornierungen werden nicht akzeptiert, wenn das Material bereits hergestellt wurde, die Produktion angelaufen ist oder die Ware gar bereits verschickt wurde. Bei der Stornierung einer Bestellung ist der Auftraggeber in jedem Fall verpflichtet, die gesamte Lieferung zu bezahlen. Falls die Stornierung akzeptiert wird, ist der Kunde verpflichtet, alle Kosten zu übernehmen, die dem Hersteller bis zu diesem Zeitpunkt entstanden sind.

9) **PREISE** - Die in unserer Preisliste angegebenen Preise sind für uns nicht verbindlich. Wir behalten uns das Recht vor, diese vor der Bestellsannahme zu ändern.

10) **ZAHLUNG** - Die Zahlungen können nur direkt an uns erfolgen. Eine Verspätung von mehr als 10 Tagen jeder geschuldeten Zahlung bzw. die fehlende Deckung eines girierten, abgetretenen oder vom Auftraggeber ausgestellten Kreditpapiers innerhalb desselben Zeitraums wird als Zahlunsfähigkeit gewertet. In diesem Fall haben wir das Recht, die Lieferungen auszusetzen und jedes bestehende Geschäftsverhältnis abzubrechen; unverzüglich die vollständige Zahlung aller unserer Forderungen im Rahmen eines Vollstreckungs- oder Sicherstellungsverfahrens rechtlich zu beanspruchen, ebenso wie eine Entschädigung; in jedem Fall sind wir 10 Tage nach Ablauf der Zahlungsfrist berechtigt, ohne Vorankündigung eine Sichteinlage zuzüglich der entsprechenden Kosten auszustellen. Außerdem werden auf den geschuldeten Betrag die jährlichen Verzugszinsen in Höhe des laufenden, um fünf Prozentpunkte erhöhten Privatdiskontsatzes berechnet.

11) **VERPACKUNGSGRÖSSE** Es werden keine Mengen unterhalb der Größe eines Kartons verkauft.

12) **EIGENTUMSVORBEHALT** Das Material bleibt auch bei regulärem Transport und normaler Rechnungsstellung bis zur vollständigen Bezahlung der Lieferung in unserem Eigentum, auch im Falle der Weitergabe oder des Verkaufs an Dritte.

13) **GERICHTSSTAND** Gerichtsstand in Streitfällen ist ausschließlich das Gericht Modena.

## LOGISTIC SERVICES

**STORNIERUNG VON BESTELLUNGEN** Für die Genehmigte Stornierung von Bestellungen von bereits an unser Lager gelieferten Materialien, und für autorisierte Rückgaben, werden 15% des Steuerwertes bzw. mindestens 20 € als Kostenbeitrag für den Transport und die erneute Auswahl in Rechnung gestellt.

**MINDESTBESTELLUNGEN** für beschränkte Bestellungen zur „Fertigstellung“ oder „Einzelabfertigung“, deren Steuerwert unter 100 € liegt, wird ein fixer Nettoaufschlag von 20 € in Rechnung gestellt.

**KOMMISSIONSZUSCHLAG** zu allen als eine volle Paletten geringere Auftrage wird ein Zuschlag von 1,50 €/Qm angewandt werden.

**DRINGENDE AUFTRÄGE** Zu Aufträgen, die ausnahmsweise in 24 Stunden abgewickelt werden sollen, wird einen Fix-Zuschlag von 30,00 € angewandt werden.

## VERPACKUNGEN

### BELASTUNG

Die Spezialverpackungen der Kollektionen wide werden zu dem Preis fakturiert, der im zusammenfassenden Teil auf Seite 379 steht.

### ZURÜCKERSTATTUNG

Unter der Voraussetzung, dass sie in gutem Zustand zurückerstattet werden, können sie zurückgesandt und wieder gutgeschrieben werden.

# ОБЩИЕ УСЛОВИЯ ПРОДАЖИ

---

- **ПОДТВЕРЖДЕНИЕ** - Поступившие к нам заказы действительны только после нашего письменного подтверждения.
- **ПОСТАВКА** - Поставка материала считается выполненной в момент окончания погрузки на наших складах. Заказчик несет все риски, связанные с транспортировкой, включая недостачу, поломку, порчу и нарушение целостности упаковки, также если на продукцию установлена цена франко-порт, FOB или C&F. Соглашения с экспедиторами всегда заключаются от имени и за счет Заказчика, который с момента заключения соглашения утверждает и принимает проделанную работу.
- **СРОКИ ПОСТАВКИ** - Сроки поставки имеют ориентировочный характер, возможная задержка поставки, ее приостановка, частичное или полное прекращение не дают права на возмещение убытков или компенсацию за ущерб.
- **ПРЕДЪЯВЛЕНИЕ ПРЕТЕНЗИЙ** - Гарантия на товар распространяется только и исключительно на первосортный материал с допуском отклонением приблизительно на 5%. Различия в оттенках не будут считаться дефектом материала. Возможные претензии в отношении качества, типа материала должны быть предъявлены в течение 8 дней с даты поставки. Покупатель обязуется предоставить признанные им дефектными партии товара для проверки обоснованности претензии; в любом случае, после укладки материала мы не несем никакой ответственности. Возможные выявленные или подтвержденные недостатки или дефекты качества товара, при условии, что покупатель заявил о них в течение установленных законом сроков, дают покупателю право только на замену дефектного материала, которая осуществляется после возврата дефектного товара и на основании акта о возврате товара, составленного в письменной форме, при этом категорически исключается отказ от договора или его расторжение, а также какое-либо возмещение убытков.
- **РАЗМЕРЫ И ОТТЕНКИ** - Наши материалы относятся к продуктам, которые подвергаются обжигу при высокой температуре, поэтому заявленные и реальные размеры поставленных изделий могут отличаться. Это касается и различий в оттенках изделия из одной и той же партии. В связи с этим размеры и оттенки не могут быть предметом рекламации со стороны заказчика.
- **УПАКОВКА И КОЛИЧЕСТВО** - Перевозчик должен проконтролировать груз по количеству и целостности упаковки при приемке товара. Перевозчик, подписывая Сопроводительную Накладную, несет ответственность за сохранность материала и за его количество. В случае обнаружения повреждений и недостачи возможные претензии о возмещении ущерба за понесенные убытки покупатель должен предъявлять перевозчику.
- **ВОЗВРАТ ТОВАРА** - Покупатель не может ни на каком основании осуществлять возврат товара без нашего предварительного письменного согласия. Все расходы будут отнесены на счет Заказчика.
- **АНУЛИРОВАНИЕ ЗАКАЗА** - Отмена заказа не будет приниматься, если материал был уже изготовлен, или если уже было начато его производство, а тем более, если уже была произведена отправка. В любом случае, при отмене заказа Заказчик будет обязан произвести оплату всей поставки. Если отмена заказа будет возможна, Клиент должен будет возместить все расходы, понесенные производителем до момента отмены.
- **ЦЕНЫ** - Цены, указанные в наших прайс-листах, имеют ориентировочный характер. Мы оставляем за собой право изменить цены перед принятием заказа
- **ПЛАТЕЖИ** - Оплата товара должна производиться только прямым платежом. Задержка более чем на 10 дней каждого причитающегося платежа или отсутствие покрытия в срок векселя, который был передан, уступлен или выставлен заказчиком, является состоянием неплатежеспособности. В таком случае мы оставляем за собой право приостановить поставку, отменить все текущие отношения, а также немедленно потребовать полной выплаты каждой задолженности и обращаться по этому поводу в суд, в исполнительном или предупредительном порядке, а также с требованием возмещения ущерба; в любом случае, по истечении 10 дней с даты причитающегося платежа, мы имеем право без предупреждения выписать переводный вексель на предъявителя с оплатой издержек. Кроме того, на просроченную задолженность начисляются проценты по неустойке по текущей процентной ставке 5 % годовых.
- **РАСПАКОВКА КОРОБОК** - Продажа товара осуществляется только целыми заводскими коробками.
- **ПРАВО УДЕРЖАНИЯ ТОВАРА** - товар остается нашей собственностью до момента полной оплаты поставки даже в случае, если была произведена отправка, и был выставлен счет-фактура также в случае передачи или продажи товара третьим лицам.
- **КОМПЕТЕНТНЫЙ СУД** - Рассмотрение любых споров будет находиться в исключительной компетенции Суда г. Модены.

## ЛОГИСТИЧЕСКИЕ УСЛУГИ

**ОТМЕНА ЗАКАЗОВ** – в случае отмены заказов на поставку материалов, уже поставленных на наш склад, покупатель обязан оплатить 15% облагаемой налогом их стоимости, а также минимальную фиксированную сумму в размере 20, взимаемую в качестве оплаты транспортных расходов и пересортировки.

**МИНИМАЛЬНЫЙ ЗАКАЗ** – в случае ограниченных заказов, представляющих собой как «отдельные заказы», так и «дополнения» к другим заказам, облагаемая налогом стоимость которых составляет менее 100, применяется чистая фиксированная надбавка в размере 20.

**НЕ ПОЛНЫЙ ПОДДОН** – для заказов менее чем полный поддон, стоимость каждого квадратного метра плитки будет увеличена на 1,50.

**СРОЧНЫЕ ПОСТАВКИ** – при подготовке заказов в течение 24 часов, содержащих максимум 2 артикула, применяется чистая фиксированная надбавка в размере 30.

## УПАКОВКА

### ОПЛАТА

Специальная упаковка коллекций wide будет оплачиваться по себестоимости, описанной в сводном разделе на стр. 379.

### ВОЗВРАТ

Упаковка может быть возвращена, а ее стоимость зачтена, при условии ее возврата в хорошем состоянии.







Marketing ABK Group  
Direfarecreate.it  
Finito di stampare Gennaio 2017

# ABK

EMOZIONI IN SUPERFICIE

ABK Group Industrie Ceramiche s.p.a. via S.Lorenzo N.24/a 41034 Finale Emilia Modena Italy tel. 0535 761311 fax 0535 761320/92800/761351

[www.abk.it](http://www.abk.it)  
[#abkemozioni](https://www.instagram.com/abkemozioni)



**ABK**  
EMOZIONI IN SUPERFICIE